

Analysis and Weight Optimization of Industrial Centrifugal Blower

Sourabh Sanjay Ghodake¹, Dr S. L. Gombi²

¹Post Graduate Student, Department of Mechanical Engineering, KLS GIT, Belgavi, Karnataka, India

²Professor of Mechanical Engineering, KLS GIT, Belgavi, Karnataka, India

Submitted: 05-06-2021

Revised: 18-06-2021

Accepted: 20-06-2021

ABSTRACT:This project provides solutions to challenges that the industry, namely Hindustan Blowers, Pune, is facing. By applying FEA to optimize crucial components of a centrifugal blower utilizing static and dynamic analysis. The current centrifugal blower is composed of M.S. material, and corrosion and weight is a significant issue. To avoid blower corrosion, this can be avoided by altering the blower material, which in this project work is SS316L and SS304. Weight of the centrifugal blower is reduced along with increase in its strength, by optimization of static analysis using FEA for the material MS, SS304 and SS316L (Food Grade Steel). In this project, a modal analysis is performed on the MS material and food-grade materials SS304 and SS316L, and the natural frequency of the material is compared to the frequency of external excitation in order to decrease vibrations and centrifugal blower fan failure.

KEYWORDS:Hindustan Blowers, Centrifugal Blower, Static Analysis, Modal Analysis, Food Grade Steel

I. INTRODUCTION

A centrifugal blower is a mechanical device that uses centrifugal force to move air or other gases or it is a form of turbo machinery that is used to transfer air continuously while maintaining air with slight increase in static pressure. A driveshaft that passes through the blower housing is turned on by the hub. The revolving impellers in these fans increase the speed of the air stream. They use the impellers or rotating blades kinetic energy to raise the pressure of the air/gas stream, which then propels them against the resistance of ducts, dampers, and other components. Centrifugal blowers accelerate air in a radial direction, shifting the direction of the airflow (typically by 90 degrees). They're tough, quiet, and dependable, and they can work in a variety of environments. Centrifugal blowers are constant CFM or constant volume devices, which means they pump a constant volume of air rather than a constant mass of air at a

constant fan speed. This implies that even if the mass flow rate through the fan is not set, the air velocity in a device is. Blower performance curves, which are described as the plot of established pressure and power needed over a range of fan induced air flow, are often analysed. These fan characteristic curves can also be applied to data such as fan horsepower to help determine which motor to use. Among the six types of impellers, centrifugal fans with Air foil section blades, Backward Inclined single thickness blades, backward curved blades, forward curved blades, radial tip blades, and radial blades are considered high performance impellers.

The type of fan system to use is determined by a number of factors, including airflow speeds, air temperature, pressures, and airstream properties. The fan is typically chosen for non-technical reasons such as price, distribution, room availability, packaging, and so on. Blowers are used in a wide range of industrial and commercial applications, including shop ventilation, material processing, boiler applications, and some vehicle cooling systems. It is also used in the transportation of gas or products, in building ventilation systems as well as they're often used in central heating and cooling systems and in submarine compartment's ventilation.

This project gives the solution to problems which are facing the industry located in Pune. By using FEA to optimize critical sections of a centrifugal blower using static and dynamic analysis. The current centrifugal blower is made of M.S. material, and corrosion is a big issue. This can be mitigated by modifying the blower material, which in this project work is SS 304 and SS316L to prevent blower corrosion. By optimizing static analysis using FEA for the materials MS, SS, and SS316L (Food Grade Steel), the weight of the centrifugal blower is reduced while its strength is increased. In this project, a modal analysis is performed on the MS material and food-grade materials SS, and SS316L, and the natural frequency of the material is compared to the frequency of

external excitation in order to minimize vibrations and centrifugal blower fan failure.

II. LITERATURE SURVEY

[1].Veeranjaneyulu Itha and T.B.S.Rao The aim of this paper is to investigate the static and dynamic analysis of a blower in order to minimize vibrations and effects. The aim of this study is to see if composites can be used instead of metal to improve vibration control. Composites, which are known for their superior damping properties, are more promising than metals in terms of vibration reduction. The first five natural frequencies are determined using modal analysis on both aluminium and composite blowers.

[2].Mohd Jubair Nizami, Ramavath Sunman to investigate the static and dynamic analysis of a blower in order to minimize vibrations and effects. Centrifugal blowers, which are commonly used for on-board naval applications, produce a lot of noise. The noise created by a rotating component is primarily caused by random loading forces on the blades and periodic iteration of incoming signals with the rotor blades. The modern blades used in naval applications are made of aluminium or steel, and they produce noise that disturbs those who work near the blower. The aim of this study is to see if composites can be used instead of metal to improve vibration control. Composites, which are known for their superior damping properties, are more promising than metals in terms of vibration reduction.

[3]. Atre Pranav C. and Thundil Karuppa Raj R. looked into how Numerical Design and Parametric Optimization of Centrifugal Fans with Air foil Blade Impellers would help increase blade efficiency and weight. Fans are a form of turbo machinery that moves air continuously with only a slight increase in static pressure. The fan system's output can vary from no air to many cfm (cubic feet per min.).The type of fan system to use is determined by a number of factors, including airflow speeds, air temperature, pressures, and airstream properties. This study explains how to design high-efficiency impellers, including the numerical design procedure and CFD analysis. The CFD part is used to boost the static pressure produced at the impeller's entry, as well as static performance. The CFD optimization also enhanced the flow pattern through the centrifugal fan system.

III. BOUNDARY CONDITIONS (BC) FOR ANALYSIS

The Impeller is investigated using the ANSYS software. CATIA V5 is used to build a 3D

model of the impeller, which is then imported into ANSYS for evaluation. The impeller's working condition serves as the boundary condition. Similar boundary conditions are used to perform various analyses. The impeller boundary conditions that were used in the study are shown below.

3.1 BC for Static Analysis

The effect of steady loading conditions on a structure is calculated using static analysis. The boundary conditions for the centrifugal blower impeller are shown in the diagram below (Fig-1). The impeller's circumference is fixed, and a torque of 67764 N-mm is applied to the impeller's center (on drive shaft hole). Complete Deformation and Equivalent (Von-Mises) Stress are measured in static analysis.

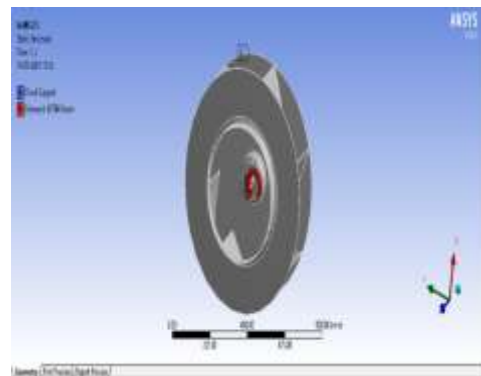

Fig-1: BC for static analysis

3.2 BC for Modal Analysis

The vibrations of a part are discovered using modal analysis. The natural frequency of vibration of the centrifugal blower impeller is measured for the project. The Natural frequency is characterized as the frequency at which the system is vibrating when it is not subjected to a continuous or rehashed external force. The natural frequency of the impeller is determined by simply fixing it at the center without applying any external force, as shown in the below figure 2.

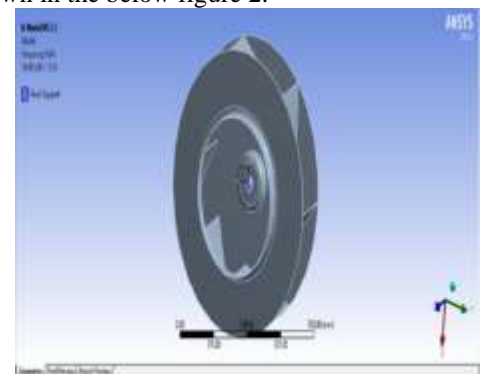

Fig-2: BC for modal analysis

IV. STATIC AND MODAL ANALYSIS OF SEVEN BLADE IMPELLER

The 3D model is prepared and the impeller with seven blades is currently used by company made up of MS material. For this analysis the impeller with seven blade is prepared.

4.1 When the Material is Mild Steel (MS)

4.1.1 Weight of the Impeller

The existing Impeller material is Mild steel. The seven blades impeller weighs 28.95 Kg.

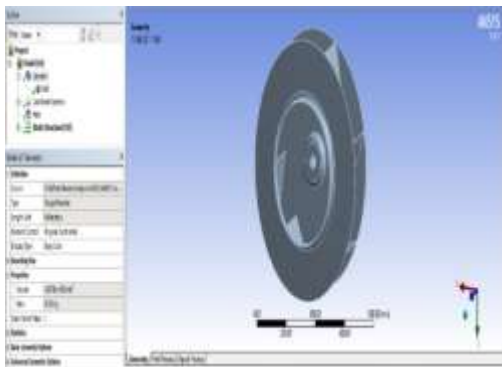

Fig-3: Weight of MS Seven Blade Impeller

4.1.2 Static Analysis

Maximum Deformation- The total deformation observed in the impeller is 0.00041962 mm.

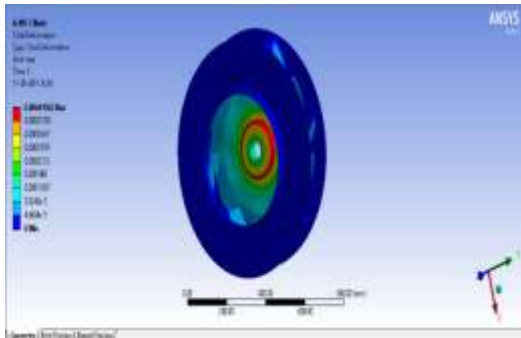

Fig-4: Deformation in MS Seven Blade Impeller

Equivalent (Von-Mises) Stress- The induced stress in the wheel is 1.2962 MPa.

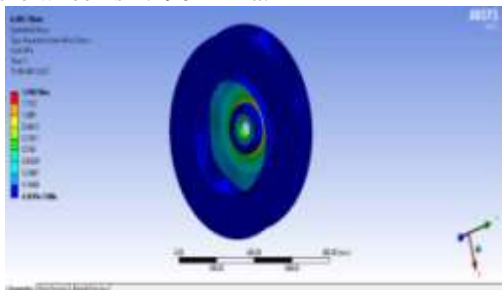

Fig-5: Equivalent stress of MS Seven Blade Impeller

4.1.3 Modal Analysis

The Existing wheel's first six Mode Shapes are presented here (Figure 6). The first mode shape is 45.032 Hz

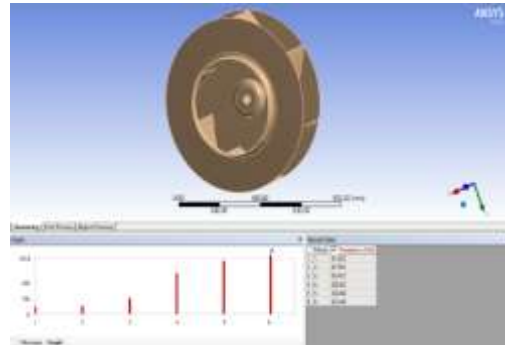

Fig-6: Mode Shapes of MS Seven Blade Impeller

4.2 When the Material is Stainless Steel SS304

4.2.1 Weight of the Impeller

The impeller of SS304 material with seven blades weights 29.31 kg.

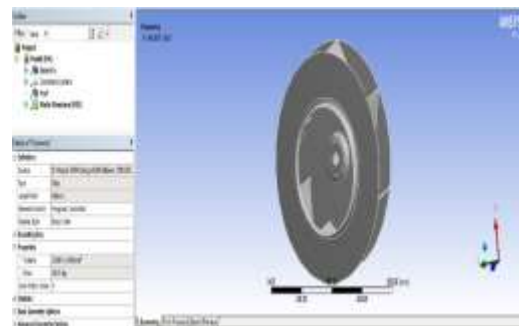

Fig-7: Weight of SS 304 Seven Blade Impeller

4.2.2 Static Analysis

Maximum Deformation- The total deformation observed in the impeller is 0.00041378 mm.

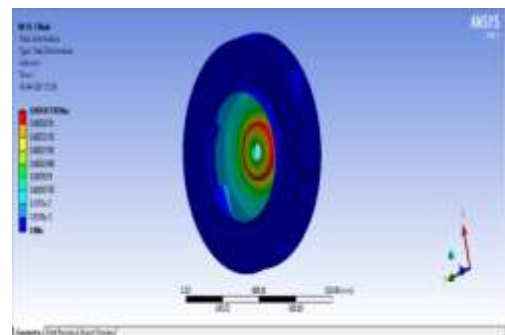

Fig-8: Deformation in MS Seven Blade Impeller

Equivalent (Von-Mises) Stress- The stress that will be induced in the wheel is 1.2732 MPa.

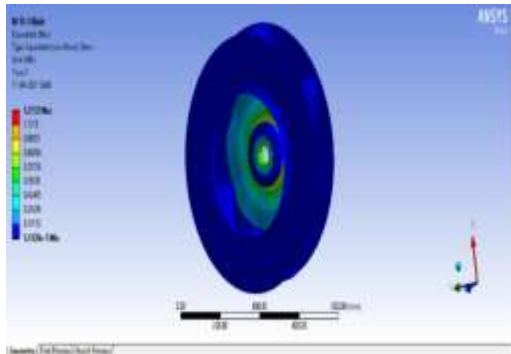

Fig-9: Equivalent stress of SS 304 Seven Blade Impeller

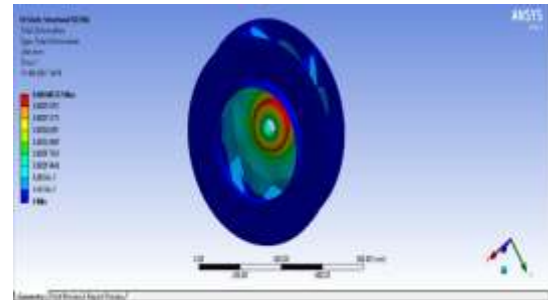

Fig-12: Deformation in SS304 Seven Blade Impeller

Equivalent (Von-Mises) Stress- The induced stress in the wheel is 1.2732 MPa

4.2.3 Modal Analysis

The impeller's first six Mode Shapes are shown here (Fig 10). The first mode shape is 45.328 Hz

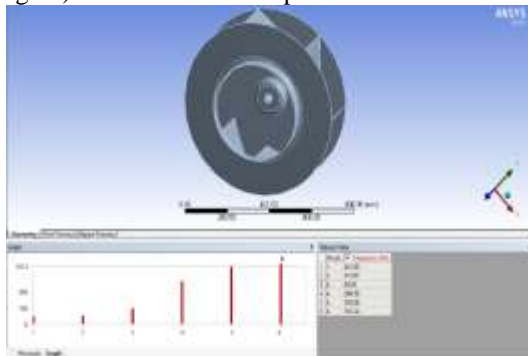

Fig-10: Mode Shapes of SS 304 Seven Blade Impeller

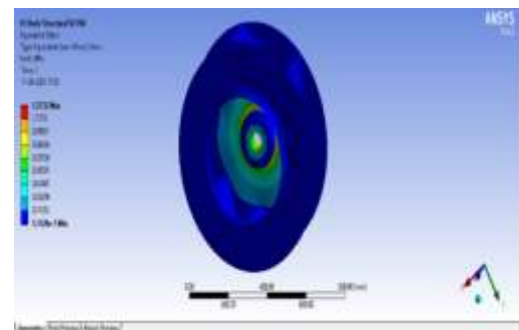

Fig-13: Equivalent stress of SS316L Seven Blade Impeller

4.3.3 Modal Analysis

The impeller's first six Mode Shapes are presented here (Fig 14). The first mode shape is 46.4 Hz

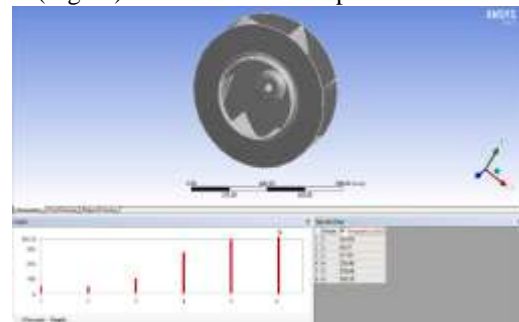

Fig-14: Mode Shapes of SS316L Seven Blade Impeller

4.3 When the Material is Stainless Steel SS316L

4.3.1 Weight of the Impeller

The impeller of SS316L material with seven blades weights 29.569 Kg.

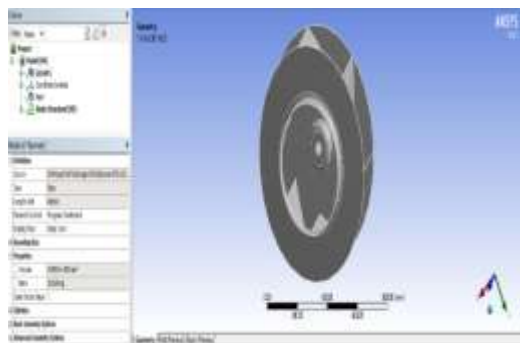

Fig-11: Weight of SS316L Seven Blade Impeller

4.3.2 Static Analysis

Maximum Deformation- The total deformation observed in the SS316L seven blade impeller is 0.00040337 mm.

The total deformation and equivalent stress obtained through analysis for both materials are lower than the existing material used by the company, Mild steel and that the first Natural frequency identified in SS316L is higher than the other two materials. As a result, the stainless steel SS316L seven blade impeller outperforms the other two materials.

V. STATIC AND MODAL ANALYSIS OF FIVE BLADE IMPELLER

The 3D model is prepared by changing the seven number of blades to five blade keeping or without changing any parameters which are necessary to fit the impeller to the casing like diameter of the Impeller or bore diameter.

5.1 When the Material is Mild Steel (MS)

5.1.1 Weight of the Impeller

This impeller has five blades and weighs 26.976 kg.

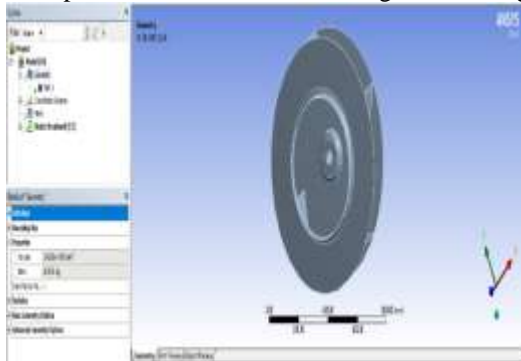

Fig-15: Weight of MS Five Blade Impeller

5.1.2 Static Analysis

Maximum Deformation- The total deformation observed in the impeller is 0.00042063 mm.

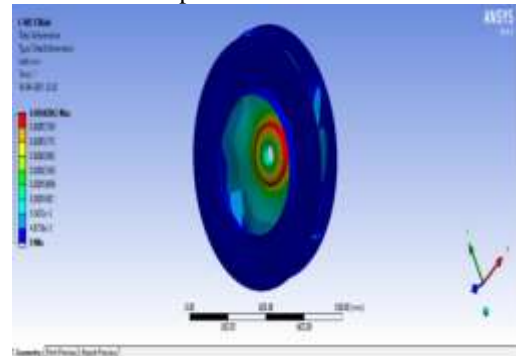

Fig-16: Deformation in MS Five Blade Impeller

Equivalent (Von-Mises) Stress- The induced stress in the wheel is 1.265 MPa.

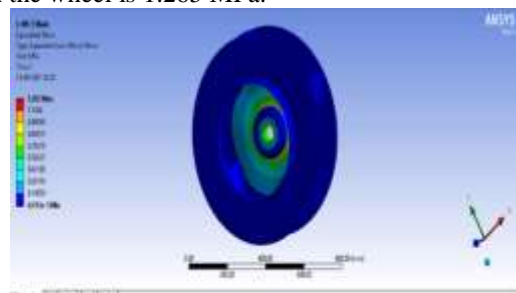

Fig-17: Equivalent stress of MS Five Blade Impeller

5.1.3 Modal Analysis

The impeller's first six Mode Shapes are presented here (Fig 18). The first mode shape is 41.878 Hz.

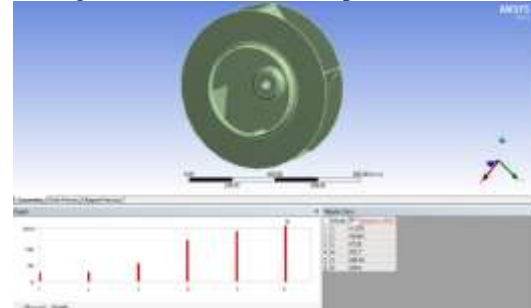

Fig-18: Mode Shapes of MS Five Blade Impeller

5.2 When the Material is Stainless Steel SS304

5.2.1 Weight of the Impeller

The Impeller is of Stainless steel SS304. The Five blades impeller weighs 27.32 Kg.

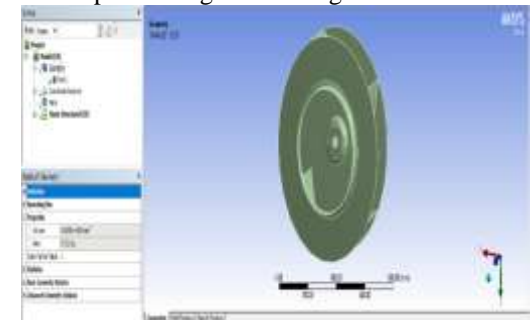

Fig-19: Weight of SS 304 Five Blade Impeller

5.2.2 Static Analysis

Maximum Deformation- The total deformation observed in the impeller is 0.00041653 mm.

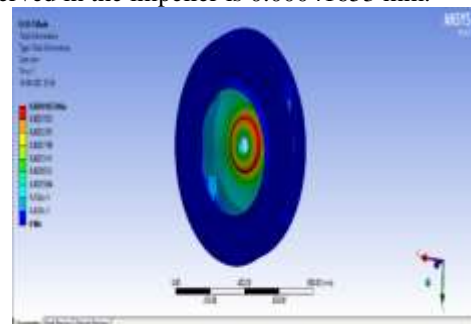

Fig-20: Deformation in SS304 Five Blade Impeller

Equivalent (Von-Mises) Stress- The stress that will be induced in the wheel is 1.2649 MPa.

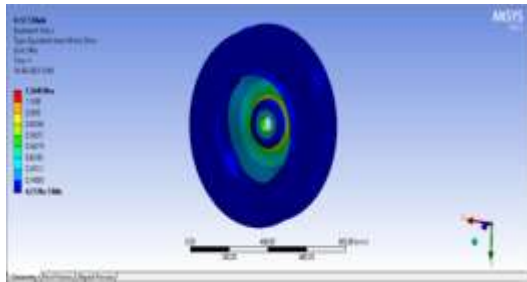

Fig-21: Equivalent stress of SS 304 Five Blade Impeller

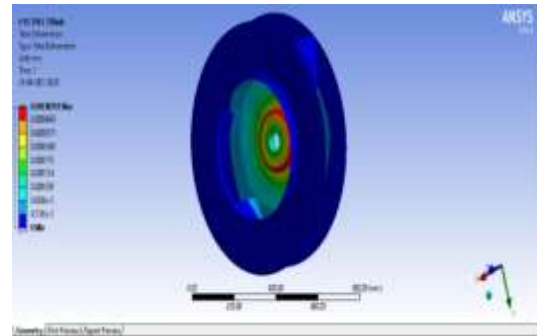

Fig-24: Deformation in SS316L Five Blade Impeller

5.2.3 Modal Analysis

The impeller's first six Mode Shapes are presented here (Fig 22). The first mode shape is 42.007 Hz

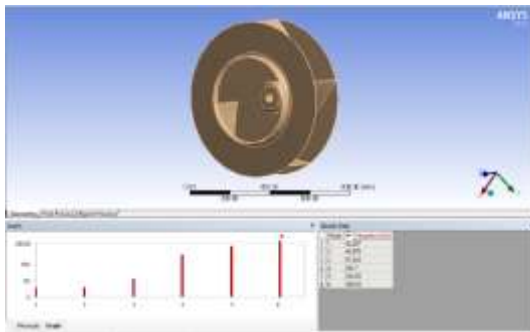

Fig-22: Mode Shapes of SS 304 Five Blade Impeller

Equivalent (Von-Mises) Stress- The induced stress in the wheel is 1.264 MPa.

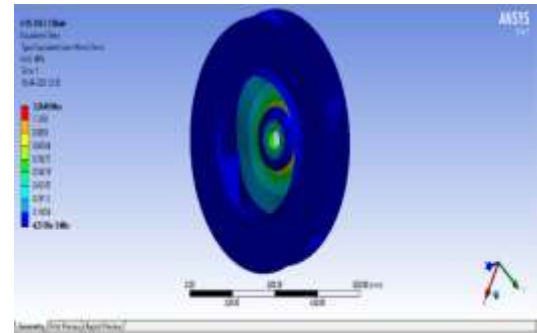

Fig-25: Equivalent stress of SS316L Five Blade Impeller

5.3 When the Material is Stainless Steel SS316L

5.3.1 Weight of the Impeller

This impeller has five blades SS316L material and weighs 27.492 kg.

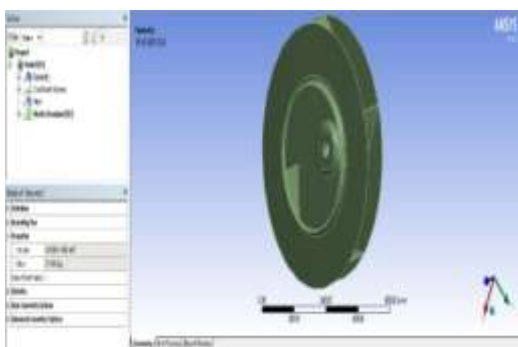

Fig-23: Weight of SS316L Five Blade Impeller

5.3.3 Modal Analysis

The impeller's first six Mode Shapes are presented here (Fig 26). The first mode shape is 42.91 Hz

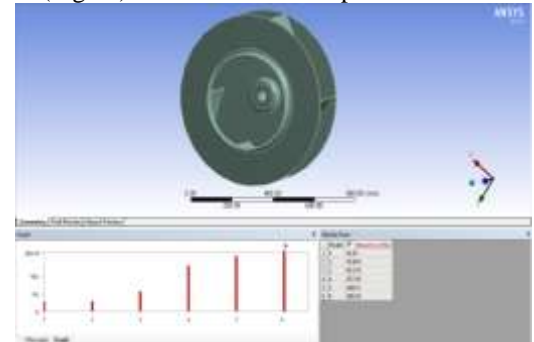

Fig-26: Mode Shapes of SS316L Five Blade Impeller

5.3.2 Static Analysis

Maximum Deformation- The total deformation observed in the SS316L five blade impeller is 0.00038791 mm.

When SS316L, MS, and SS304 materials are compared in terms of deformation and equivalent stress, the deformation and equivalent stress of SS316L is lower. SS316L also has a higher natural frequency than the other two materials, which is advantageous. As a conclusion, for further comparison, the SS316L Five blade impeller is chosen.

VI. STATIC AND MODAL ANALYSIS OF NINE BLADE IMPELLER

The 3D model is prepared by changing the seven number of blades to nine blade keeping or without changing any parameters which are necessary to fit the impeller to the casing like diameter of the Impeller or bore diameter.

6.1 When the Material is Mild Steel (MS)

6.1.1 Weight of the Impeller

The nine blades MS material impeller weighs 31.05 Kg.

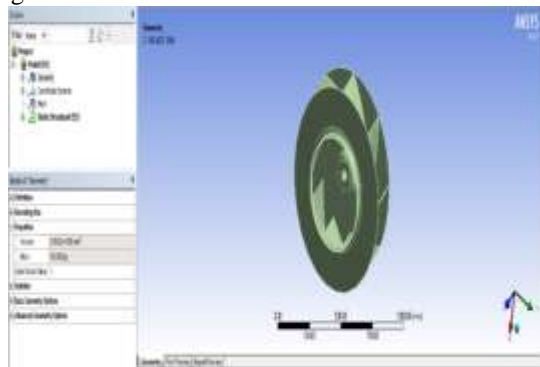

Fig-27: Weight of MS Nine Blade Impeller

6.1.2 Static Analysis

Maximum Deformation- The total deformation observed in the impeller is 0.00042257 mm.

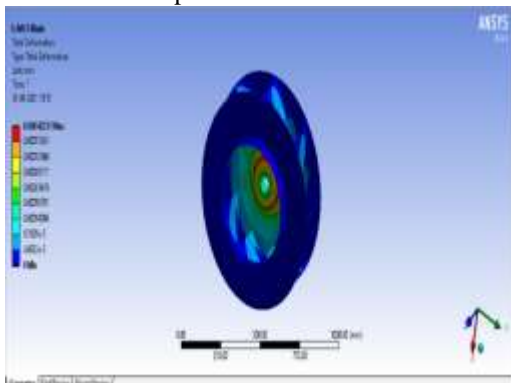

Fig-28: Deformation in MS Nine Blade Impeller

Equivalent (Von-Mises) Stress- The induced stress in the wheel is 1.2787 MPa.

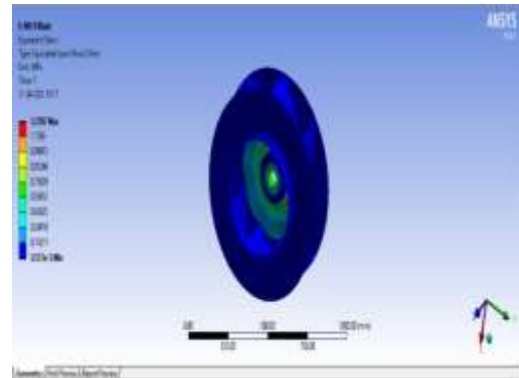

Fig-29: Equivalent stress of MS Nine Blade Impeller

6.1.3 Modal Analysis

The impeller's first six Mode Shapes are presented here (Fig 18). The first mode shape is 42.491 Hz

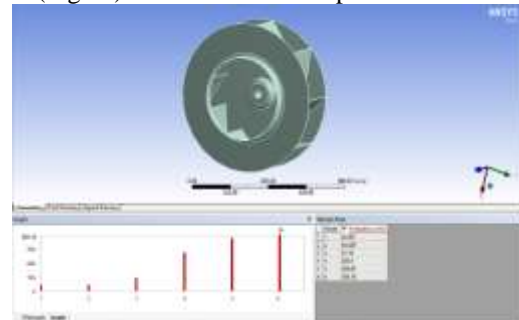

Fig-30: Mode Shapes of MS Nine Blade Impeller

6.2 When the Material is Stainless Steel SS304

6.2.1 Weight of the Impeller

The Impeller is of Stainless steel SS304. The nine blades impeller weighs 31.452 Kg.

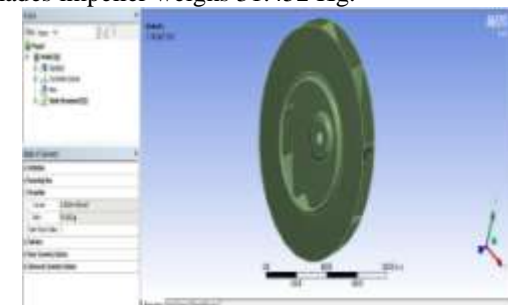

Fig-31: Weight of SS 304 Five Blade Impeller

6.2.2 Static Analysis

Maximum Deformation- The total deformation observed in the impeller is 0.00042577 mm.

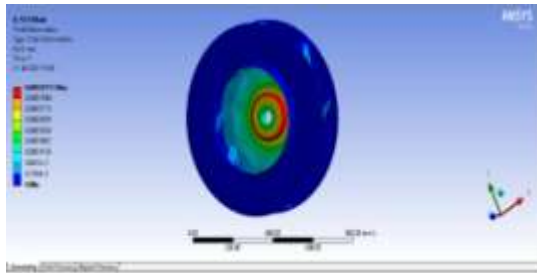

Fig-32: Deformation in SS304 Nine Blade Impeller

Equivalent (Von-Mises) Stress- The stress that will be induced in the wheel is 1.2784 MPa

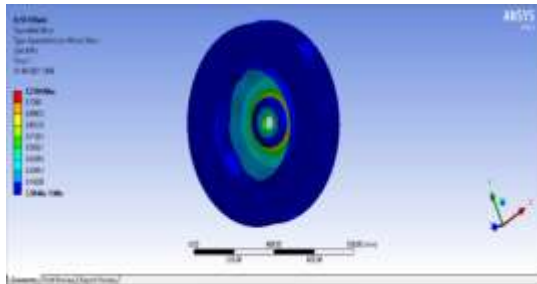

Fig-33: Equivalent stress of SS 304 Nine Blade Impeller

6.2.3 Modal Analysis

The wheel's first six Mode Shapes are presented here (Fig 22). The first mode shape is 43.167 Hz

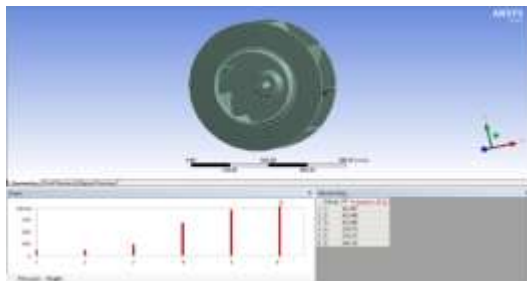

Fig-34: Mode Shapes of SS 304 Nine Blade Impeller

6.3 When the Material is Stainless Steel SS316L

6.3.1 Weight of the Impeller

The SS316L impeller weighs 31.65 Kg.

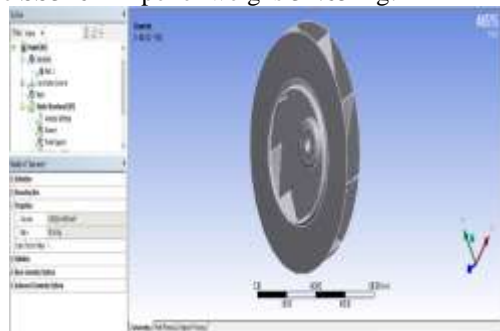

Fig-35: Weight of SS316L Nine Blade Impeller

6.3.2 Static Analysis

Maximum Deformation- The total deformation observed in the SS316L seven blade impeller is 0.00040549 mm.

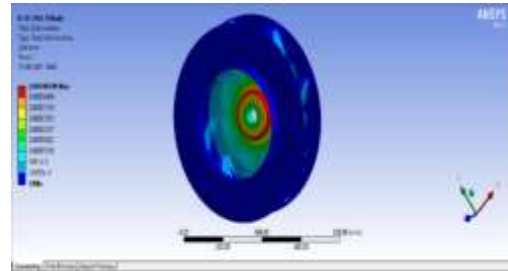

Fig-36: Deformation in SS316L Nine Blade Impeller

Equivalent (Von-Mises) Stress- The induced stress in the wheel is 1.2784 MPa.

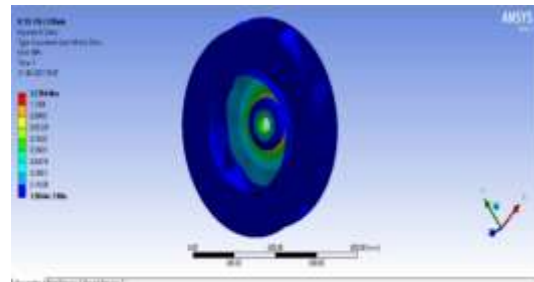

Fig-37: Equivalent stress of SS316L Five Blade Impeller

6.3.3 Modal Analysis

The impeller's first six Mode Shapes are presented here (Fig 38). The first mode shape is 43.537 Hz

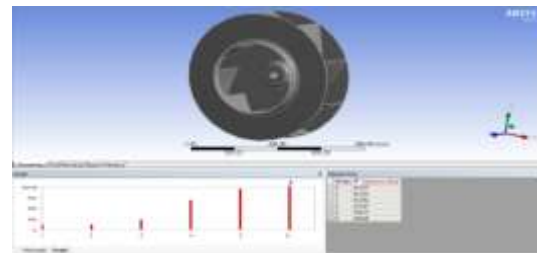

Fig-38: Mode Shapes of SS316L Nine Blade Impeller

The findings obtained from analysis for MS, SS304, and SS316. From these data, we can conclude that total deformation and equivalent stress are lower for SS316L material, also initial natural frequency is higher than the MS and SS304 material. As a result, we chose SS316L over MS and SS304 materials.

VII. CONCLUSIONS

Table -1: Impeller Blade analysis results Comparison

S. No.	Seven Blade SS316L	Five Blade SS316L	Nine Blade SS316L
Weight (Kg)	29.569	27.492	31.65
Total Deformation (mm)	0.00040337	0.00038791	0.0004054
Equivalent Stress (MPa)	1.273	1.264	1.278
First Natural Frequency (Hz)	46.455	42.91	43.537

As per Discussion with concerned person of the industry we know that their current impeller is made up of MS material which has 29 Kg of weight. It operates at speed of 1440 rpm and its working frequency is 24 Hz.

As part of our project's aim, we need to minimize the weight and improve the strength of the centrifugal blower's impeller. The results in table 1 show that the five-blade SS316L material performs better than the seven- and nine-blade SS316L materials, despite the fact that the first natural frequency of all impeller materials is higher than the working frequency, which is safe. The weight of the Five Blade impeller blade is smaller than that of the existing impeller blade, which meets our goal, and the stresses and deformation are also reduced. As a result, Five Blade SS316L is chosen as the best choice for future investigation.

REFERENCES

- [1] Veeranjanyulu Itha, T.B.S.Rao, "Static and Dynamic Analysis of a Centrifugal Blower Using Fea" International Journal of Engineering Research & Technology (IJERT) Vol. 1 Issue 8, October - 2012 ISSN: 2278-0181, pp. 1-11.
- [2] Mohd Jubair Nizami, Ramavath Sunman, "Evaluation of Static & Dynamic Analysis of a Centrifugal Blower Using Fea" International Journal Of Advanced Trends in Computer Science and Engineering, Vol.2, Issue 7, January-2013, pp. - 316-321.
- [3] Atre Pranav C. and Thundil Karuppa Raj R. "Numerical Design and Parametric Optimization of Centrifugal Fans with Air foil Blade Impellers" Research Journal of Recent Sciences Vol. 1(10), 7-11, October (2012) - ISSN 2277-2502
- [4] Jia Bing Wang Huazhong "Numerical Analysis of Internal Flow Field of Multi-Blade Centrifugal Fan for Floor Standing Air-Conditioner" International Refrigeration and Air Conditioning Conference.
- [5] M. Carudina, "Noise generation in vane axial fans due to rotating stall and surge", Journal of Mechanical Engineering Science, Volume 215, Number 1, pp. 57-64, 2001
- [6] C. Cuevas Arteaga1, J. Porcayo Calderón "Comparison of Corrosion Resistance of Carbon Steel and Some Stainless Steels Exposed to LiBr-H2O Solution at low Temperatures" International Journal Of Electrochemical Science, Volume 7, 2012, pp. 445-470.