

Automated Portable Hammering Machine

Arpan Chakraborty, Somnath Mondal, Akarshan Basu, Shubhrajyoti
Das, Prof. Sandip Kumar Chaudhury

MaulanaAbulKalam Azad University of Technology

Prof.(Dr.) Rahul Baidya, Prof.(Dr.) Arun Kumar Bar

Co-ordinator Project Review Committee Dept. of Mechanical Engineering

Institute of Engineering & Management

Dean (Engineering) & Head of the Department Dept. of Mechanical Engineering

Institute of Engineering & Management Sector-V, Salt Lake Electronics Complex, Kolkata-700091

Submitted: 10-06-2021

Revised: 21-06-2021

Accepted: 24-06-2021

CERTIFICATE OF APPROVAL

This foregoing **AUTOMATED PORTABLE HAMMERING MACHINE**, 4th Year Project is hereby approved as a credible study of an engineering subject carried out and presented in a manner satisfactory to warrant its acceptance as a prerequisite to the degree for which it has been submitted. It is understood that by this approval the undersigned do not endorse or approve any statement made, opinion expressed or conclusion drawn therein but approve the 4th Year Project only for the purpose for which it is submitted.

ACKNOWLEDGEMENT

We should like to take this opportunity to extend our gratitude to the following revered persons without whose immense support, completion of this project wouldn't have been possible.

We are sincerely grateful to our advisor and mentor **Prof. Sandip Kumar Chaudhury** of the **Department of Mechanical Engineering, IEM** Kolkata, for his/her constant support, significant insights and for generating in us a profound interest for this subject that kept us motivated during the entire duration of this project.

We would also like to express our sincere gratitude to **Prof. (Dr.) Satyajit Chakrabarti** (Director, IEM) and **Prof. (Dr.) Arun Kumar Bar** [Dean (Engineering), IEM] and other faculties of Institute of Engineering & Management, for their assistance and encouragement.

Last but not the least, we would like to extend our warm regards to our families and peers who have kept supporting us and always had faith in our work.

ABSTRACT

The concept of an automatic hammering machine in this paper has been shown to have a place in the actual market and to fill a need demanded by potential customer. In this paper, the concept of automatic hammering machine prototype will have to fulfill the basic design requirement, let us add the proposed concept will a few more lines about our impression project work. Help in production line where many workers are used for the material handling purpose it also reduce the cost and threshing time requirement of more number of worker will completely eliminated as only two workers can carried out the be complete operation. The project objective originally is to reduce human efforts in manufacturing industries. The in future the complete stress analysis of the project model could be done. This analysis could be done by us. Moreover, for the automatic hammering machine to achieve fully success in the future, many collateral improvement must be done in terms of systems (autopilot technology, for instant) and time delay management (pedal operated control will be required) and some modification can will be done in this project.

Keywords: 1. Automated Hammering Machine,
2. Prototypes,
3. Material Handling,
4. Manufacturing,
5. Stress Analysis,
6. Time Delay Management.

I. INTRODUCTION

MOTIVATION:-In many industries various types of machines and equipment have been used for various operations such as forging, hammering,

cutting etc. But different problems such as low power supply, less man power and also heavy laborious work force, safety etc. This projects relates to operation performed by this can be achieved by either using electric motor power. Mainly in the rural areas there are many few skilled labors and they don't have machines and resources like big industrial companies so our main motivation is to help them by creating this project which will be cost friendly for them and also enhance their work efficiency .

OBJECTIVE:-Determination of impact velocity and torque force of hammer. To determine the time required for the various operations. To Prepare the model of project on PTC CREO PARAMETRIC. Automation with minimum man-power. Low initial and operating cost. Useful for mass production as time required is less.

ORGANIZATION:-Our main target here to built this automated hammering machine to help workers in the rural area. Our project report contains our whole planning. That includes our theoretical approach and collection the knowledge about previously done work on this project, our innovative idea , the components we need to execute it with specification, our required calculations, and the sectors we want to use the machine .

BACKGROUND

Hammering is the most widely used industrial as well as construction activity. Hammering or screws, metal sheets, parts etc requires a lot of time and effort.Hence we propose an automated hammering mechanism that allows for fully automatic hammering process. This allows for accurate, fast and automated hammering wherever and whenever needed using a 12V battery. The person just needs to insert work piece and start the hammering machine. This machine can be used for automatic hammering work as and when needed. We here, use a dc motor in order to move the hammer. The DC motor consists of a pulley attached to it which is connected to a larger pulley for efficient power transfer and to increase torque. This large pulley is connected to a shaft that has a connecting rod attached to it. This rod is used to achieve lateral motion from the spinning shaft. We now connect the other end of hammer to this connecting rod through a mid swinging arrangement in order to achieve desired hammer motion with enough torque. We now use a suitable bed where work piece can be placed. This automatic hammer is used to for all industries. The hammer is operated in pneumatic power.

II. LITERATURE REVIEW

Leonardo's invention the cam hammer is another example of thinking centuries ahead of his time. This machine would be used extensively several hundreds of years after his death during the industrial revolution. They would be powered by Steam engine and could hammer at up to twenty times per second. They were used to draw out the sheet metal for ships and armored machines for war such as the tanks in world war 1.

Here are some research works done in this topic:

[1]. Howard Terhune, Cleveland, Ohio, United States Patent office journals, Application – September 27, 1944, Serial no. 555977, Patented Oct. 28, 1947, Published no. US2429780 :

This invention relates to portable motor operated and manually controlled machine tools or implements, and more specifically to an improved hammer tool and operating mechanisms of the reciprocating, rotary cam actuated type, and designed for interchangeable use as a portable power operated hammer, wood chisel, scaling chisel, piercing punch, rock drill and other similar power tools

[2]. Harold S. Sheldon, Tekoa, Washington DC, United States Patent office journals, Application – October 15, 1947, Serial no. 779931, Patented – March 21, 1950, Published no. US2501542 :

The invention here disclosed relates to steam and air hammers of the pile driver type and in which, usually the motive fluid is just admitted to lift and then released to drop the ram to achieve a strong downward force to executing any hammering operations. Another objective of this invention is also taking less time and reducing the breaking probability of the load or other parts attached to the ram providing hammering action down the line.

[3]. J.J. Kupta Et Al, United States Patent office journals, Application – December 2, 1955, Serial no. 550718, Patented Oct. 23, 1957, Published no. US2789540:

This project found very useful when finding out during the literature survey. This project is simply is an improvement of forging hammers used for industrial purposes. As we aware that in forging operation the temperature of the metal part is so high that manual hammering operation is quite difficult for this purpose. So in this project they provided control valves which directing the ram up or down by the steam power. So that ram is moved up and down with attached hammer automatically. So we can provide automatic control over hammer for the purpose of vital operation like forging.

[4]. James Kepnar, Lawrenceville, GA (US), United States Patent office journals, Application filled – March 23, 2001, Serial no. 09/815,677, Patented September. 26, 2002, Published no. US 2002/0133997 A1 :

This invention relates to the field of firing mechanisms for single shot rifles, more particularly to a cam operated, falling block firing mechanisms incorporating a pivoted breechblock link.

[5]. David A. Giardino, Utica; William K. Wallace, Barneveld; Joseph R. Groshans, Clinton, all of N.Y, United States Patent office journals, Application – September 25, 1989, Patented Jan. 28, 1992, Patent no. 5083619 Published no. US5083619 :

objective of this invention is also taking less time and reducing the breaking probability of the load or other parts attached to the ram providing hammering action down the line.

(3)

[6]. Ulrich Demuth, Erbach-Ernst; Winrich Habedank, Diez, both of Germany, United States Patent office journals, Application - November 20, 1996, Patented August 29, 2000, Patent no. 6109364, Published no. US006109364A :

It relates to a hammer with a tool holder and a hammer mechanism for the transmission of impact energy onto the drilling bit in the tool holder has a switching device which with a single actuator makes it possible to switch between pure drilling operation, rotary hammering operation and pure hammering operation

[7]. John Byron Henry, "FORGING HAMMER" United States Patent Office Journals, application March 19, 1924, Serial no. 700255, Patented Feb 17, 1925, Published no. US 1526339 A :

This invention deals with the crank-shaft mechanism that is used in the automated hammering machine.

[8]. Production Technology By R K JAIN Publisher: Khanna Publishers; 17th edition (2004) Language: English ISBN-10; 8174090991 :

This publication gives basic overview of the machine mechanism and the working principle. And also gives us the ways to improve the efficiency of the machine.

[9]. Design Data for Machine Elements by B.D. Shiwalkar (pg. 109 to 124, pg. 125 to 131, pg. 150 to 154. pg. 155 to 160, pg. 39: It gives us the idea of what material we should use . And also the properties of the job that should be used to forge by this machine.

[10]. John Byron Henry, "FORGING HAMMER" United States Patent Office Journals, application

March 19, 1924, Serial no. 700255, Patented Feb 17, 1925, Published no. US 1526339 A:

Invention relates to power hammers, and particularly to steam forge hammers including a supporting frame, a hammer operating power cylinder provided with a piston and piston rod carrying a ram or hammer attached.

[11]. Richard W. Hall, et.al, invention is to double acting forging hammers and, more particularly, to forging hammers actuated by pressurized gas and/or hydraulic fluid. Accordingly, there is a need for double-acting forging hammer which utilizes pneumatic and/or hydraulic hammer driving systems, yet does not have the energy losses associated with pneumatic systems or the complexity and sophistication of hydraulic systems.

[12]. P. K. Oke, Journal of Engineering & Applied Sciences 2, Medwell Journals, 2007 :This paper is basically a case study which involves the improvement of the quality & quantity of the local blacksmith workshops & their products in the rural regions of Nigeria. The research consisted of survey of the blacksmiths shops, where a questionnaire was prepared to use as an instrument & were administered by the local shops. The survey was done in the capital state regions of Nigeria like Ekiti, Lagos, Kwara, Ogun, Ondo, Osun & Oyo states.

[13] Will. B. Doering To:

Overcome the problems arising due to the traditional blacksmith processes such as the wastage of time & energy, power hammers were developed. These hammers proved to be useful as the time required to produce the components was greatly reduced & also saved more human efforts. But these machines were built in a very rigid & bulky construction. To overcome this problem the author of this paper designed a more compact forging machine which occupied less floor space & can be easily moved from one place to another

(4)

[14]. Hadi & Mohd. Ibrahim, et al In:

This research work the belt drive mechanism was skipped & gasoline engine was incorporated into the hammer mill machine. This design consisted of hammer mill design & configuration of the same, determination of the power & torque transmission, determination of the centrifugal force, determination of maximum bending moment & lastly the study of damping characteristics of the machine.

[15]. P. K. Oke, Journal of Engineering & Applied Sciences 2, Medwell Journals, 2007: It deals with the material quality and the selection of metals .

[16]. Production Technology By R K JAIN
Publisher: Khanna Publishers; 17th edition (2004)
Language: English ISBN-10; 8174090991 :
Objective of this invention is also taking less time and reducing the breaking probability of the load or other parts attached to the ram providing hammering action down the line.

[17]. Carl W. Shattuck "FORGING HAMMER (FLUID OPERATED)" United States Patent Office Journals, Application- December 2, 1955, Serial no. 550718, Patented Oct 23, 1957, Published no US2789540:

Invention relates generally to portable motor-operated and manually controlled machine tools or implements, and more specifically to an improved hammer tool and operating mechanism of the reciprocating,

[18]. David H. Myaszko, Mechanisms and machine analysis – This invention relates to the detailed mechanism of the machine and how each component should be chosen.

[19]. E. Re, P-G. Magnani, T. Ylikorpi, G. Cherubini, A. Olivieri, "'DeeDri' Drill Tool Prototype and

Drilling System Development for Mars Soil Sampling Applications", 7th ESA Workshop on Advanced

Space Technologies for Robotics and Automation ASTRA 2002, ESTEC, Noordwijk, The Netherlands,

19-21 November 2002.:

This workshop was based on selection of the tool were using to do the forming operations.

[20]. Mänttari, M, "Laboratory scale rock drillability tests", Licentiate thesis, Helsinki university of technology, 1997 :

This experiment gives us the result of a technology development programme "Down hole hammering mechanism for a planetary drill".

PROPOSED STRATEGY

- The driven pulley attached with the motor is connected to a bigger pulley with the help of a V-Belt.
- The Bigger pulley is connected to a CAM with the help of a shaft which is mounted on a frame using bearings and a bearing holder.
- As soon as the motor starts, the smaller pulley which is the driven pulley rotates which in turn rotates the bigger pulley attached to it by means of a V-Belt.
- The CAM attached to it also rotates in the same direction as the bigger pulley.
- The roller follower follows the rotation of the CAM.

- Anvil and Hammer are used to give the desirable shape to the workpiece by continuously hammering the hot workpiece.
- The roller follower is attached to the arm of the hammer and is pivoted at the other end. The hammer oscillates about the pivot.

III. EXPERIMENTAL SETUP AND PRACTICAL IMPLEMENTATION

Experimental Setup:

DC MOTOR:A DC motor of any class of rotational electrical machines that delivers coordinate current electrical vitality.

DISC:A disc is a wheel on a hub or shaft that is intended to help develop and alter the course of a rigid link or belt. The disc, having eccentric holes in which bolts are fitted, is used to connect linkages.

HAMMER:In this project we have used hammer having weight 2 kg for various operations such as punching, upset forging, riveting, etc. these types of manufacturing operations are used in manufacturing industries.

MOTOR DRIVE SHAFT:A drive shaft or Cardin shaft is a mechanical part to transmit torque and revolution, typically used to associate different segments of a drive that can't be associated straightforwardly as a result of separation or the need to take into account relative development between them. The shaft is connected to eccentric disc and is transfers rotational motion from motor to hammer rod.

CAM:The cam will be connected to the motor via the bigger pulley, so that the cam rotation can give the hammer a reciprocating motion.

SOLAR PANEL:The solar panel will be connected to the battery for charging.

CALCULATIONS

Total weight of the machine = 8kg

Hammer length= 2kg

Hammer stroke height =200mm

Width= 360mm

Height= 450mm

Battery= 12v and 8Amp

Motor = 12v, DC motor, 30 rpm

Disc thickness = 1mm

Diameter of pulley= 250mm

Length of link rod= 2mm

Total Hammer weight= $2 \times 9.81 = 19.62N$

To calculate maximum torque by motor

Motor rating
 $N=30\text{rpm}$
 $I=8\text{A}$
 $V=12\text{v}$
 Power transmitted by motor
 $P=V*I=12*8=96\text{w}$
 $P=2*3.14*30*T/60$
 $T=30.55\text{ M-mm}$

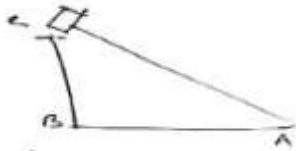

By Pythagoras theorem
 $AB=458.25\text{ mm}$
 Case-1
 When Hammer moves downward,
 $BC=h=200\text{mm}$
 Maximum torque= 30.55N-m
 Length of hammer rod= 0.5m
 Torque force= $[T_{\text{max}}/4]*0.5 = 76.375\text{N-m}$.

Case-2
 When the hammer goes upward,
 $T_f = T_{\text{max}}/4 * [\text{length of the hammer}] - \text{weight of the hammer}$
 $= 56.735\text{ N-m}$
 Impact velocity of the hammer = $h*t = .2*2 = 0.4\text{ m/sec}$

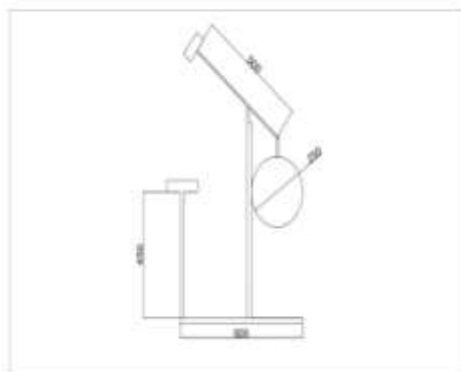

PRACTICAL IMPLIEMENTATION

Practical Implications:

The Project of Automated Portable Hammering machine has many practical implications in small manufacturing industries and in rural Economy to perform different operations as follows:

1. To perform Black Smith forging operations:

This project can be helpful in performing Black Smith forging operations and thus can help rural Economy.

2. To perform the punching operations:

Automated Portable Hammering machine can be used to perform the punching operations as it is automated and portable also.

3. To perform filleting Operations:

The torque force produced in the Automated portable hammering machine is sufficient to perform filleting Operations. Thus it can be very useful instrument to perform filleting operation.

4. To perform riveting operations:

Riveting operations can be performed with the help of Automated Portable Hammering machine. Thus this project can be practically implemented in above various operations and it can be very handy in reducing time and Labour work for ramming operation.

COST ESTIMATION

COMPONENTS	ESTIMATED PRICE (IN RS.)
HAMMER: Specifications: Weight – 2 KG Stroke Height – 200 mm. Hammer Length – 500 mm.	700 Rs.
DC Motor: Specifications: 12V – 30RPM	370 Rs.
DISC: Specifications: Diameter – 250mm	500 Rs.
FRAME: Specifications: Frame Height – 450mm Frame Length – 600mm	2000 Rs.

LINK ROD: Specifications: Length of the Rod – 200mm	400 Rs.
BATTERY: Specifications: 12V – 8A	530 Rs.
SOLAR PANEL: Specifications: 20 Watt	1000 Rs.

IV. RESULT

In this project of Automated Portable Hammering machine by using different parameters power transmitted by motor is calculated and in both the cases (When Hammer moves downward and upward) the torque forces required are calculated. The impact velocity of hammer is also calculated. Finally it is verified that the torque force required in practical implications is successfully produced by this project of Automated Portable Hammering machine.

PROJECT COMPLETION PLAN

PROGRESS MADE AND PLANS	DATES
Report Topic and Mentor Finalization.	12 th August, 2020
Synopsis approved by the supervisor	13 th August, 2020
Proposed Project Work Presentation	18 th August, 2020
Project approved by PRC (Project Review Committee)	25 th August, 2020
Project Progress Report submitted	19 th January, 2021

Final Report for Odd Semester (7th semester)	4 th March, 2021
3D Model to be submitted to the Supervisor	April, 2021
Final Semester Project Report Submission	June, 2021

V. CONCLUSION – FUTURE SCOPE AND SOCIAL IMPACT

In this paper, the concept of automatic portable hammering machine will have to accomplish the basic design requirement. We will be using a solar panel to charge the battery and drive the motor. Help in production line where many workers are used for the material handling purpose, it also reduce the cost and save time. The project objective originally is to reduce human efforts in manufacturing industries. This analysis could be done by us. Moreover, we will be using a Cam-follower mechanism for the hammer to strike the hot workpiece continuously and in order to give the desired shape and size to the workpiece.

REFERENCES

- [1]. Howard Terhune, Cleveland, Ohio, United States Patent office journals, Application – September 27, 1944, Serial no. 555977, Patented Oct. 28, 1947, Published no. US2429780
- [2]. Harold S. Sheldon, Tekoa, Washington DC, United States Patent office journals, Application – October 15, 1947, Serial no. 779931, Patented – March 21, 1950, Published no. US2501542
- [3]. J.J. Kupta Et Al, United States Patent office journals, Application – December 2, 1955, Serial no. 550718, Patented Oct. 23, 1957, Published no. US2789540
- [4]. James Kepnar, Lawrenceville, GA (US), United States Patent office journals, Application filled – March 23, 2001, Serial no. 09/815,677, Patented September. 26, 2002, Published no. US 2002/0133997 A1
- [5]. David A. Giardino, Utica; William K. Wallace, Barneveld; Joseph R. Groshans, Clinton, all of N.Y, United States Patent office journals, Application – September 25,

- 1989, Patented Jan. 28, 1992, Patent no. 5083619 Published no.US5083619
- [6]. Ulrich Demuth, Erbach-Ernst, Winrich Habedank, Diez, both of Germany, United States Patent office journals, Application - November 20, 1996, Patented August 29, 2000, Patent no. 6109364, Published no. US006109364A
- [7]. Theory of Machines by R. S. Khurmi and J. K. Gupta (pg. no. 774 to 832) 4th edition
- [8]. A Textbook of Machine Design by R. S. Khurmi and J. K. Gupta (pg. no. 509 to 557, Chapter 14. Shaft, pg. no.759 to 775, Chapter 21. Chain Drive, pg. no.996 to 1020, Chapter 27. Bearings, pg. no.1021 to 1124, Chapter 28, 29, 30, 31)
- [9]. Design Data for Machine Elements by B.D. Shiwalkar (pg. 109 to 124, pg. 125 to 131, pg. 150 to 154. pg. 155 to 160, pg. 39
- [10]. John Byron Henry, "FORGING HAMMER" United States Patent Office Journals, application March 19, 1924, Serial no. 700255, Patented Feb 17, 1925, Published no. US 1526339 A
- [11]. Howard Terhune, "HAMMER TOOL" Cleveland, Ohio, United States Patent Office Journals, Application September 27, 1944, Serial no. 555977, Patented Oct. 28, 1947, Published no. US2429780.
- [12]. Harold S. Sheldon, "COMPOUND HAMMER" Tekoa, Washington DC, United States Patent Office Journals, Application-October 15, 1947, Serial no. 779931, Patented- March 21, 1950, Published no. US2501542
- [13]. J.J. Kupta, Gladstone, and Carl W. Shattuck "FORGING HAMMER (FLUID OPERATED)" United States Patent Office Journals, Application- December 2, 1955, Serial no. 550718, Patented Oct 23, 1957, Published no US2789540.
- [14]. Richard W. Hall, "DOUBLE ACTING FORGING AND METHOD" United States Patent Office Journals, Application- January 10, 1989, Serial no 06/458,598, Published no. US 4796428 A
- [15]. James Kepnar, "CAM OPERATED, SINGLE SHOT, FALLING BLOCK FIRING MECHANISM FOR A RIFLE" Lawrenceville, GA (US), United States Patent Office Journals, Application filled - March 23, 2001, Serial no. 09/815,677, Patented September 26, 2002, Published no US 2002/0133997.
- [16]. Production Technology By R K JAIN Publisher: Khanna Publishers; 17th edition (2004) Language: English ISBN-10; 8174090991
- [17]. A Textbook of Manufacturing Technology By P N RAO Publisher; Laxmi Publication; Second edition (2016)
- [18]. David H. Myaszak, Mechanisms and machine analysis - 4th edition.
- [19]. Design Data for Machine Elements by B.D. Shiwalkar (pg. 109 to 124, pg. 125 to 131, pg. 150 to 154. pg. 155 to 160, pg. 39
- [20]. A Textbook of Manufacturing Technology By PN RAO Publisher; Laxmi Publication; Second edition (2016) Language: English ISBN-10: 8131802442
- [21]. Machine design book RS khurmi & JK gupta for theory
- [22]. David Harries & Bernard Heer, Intermediate Technology Publications, 1993, ISBN 1853391956 [2] A. R. Sahu & U. D. Gulhane, 13th September 2003
- [23]. P. K. Oke, Journal of Engineering & Applied Sciences 2, Medwell Journals, 2007
- [24]. Doerting, Will. B. (2011), Kaleidoscope: Vol-10, Article 09
- [25]. Hadi & Mohd. Ibrahim, et al, Journal of Engineering & research, Vol-6, Issue-3, pp-139-146, 201
- [26]. T. Ylikorpi, G. Visentin, J. Suomela, "A robotic rover-based deep driller for Mars exploration", Proceedings of the 35th Aerospace Mechanisms Symposium, Ames Research Center, USA, May 9-11, 2001.
- [27]. E. Re, P-G. Magnani, T. Ylikorpi, G. Cherubini, A. Olivieri, "'DeeDri' Drill Tool Prototype and Drilling System Development for Mars Soil Sampling Applications", 7th ESA Workshop on Advanced Space Technologies for Robotics and Automation ASTRA 2002, ESTEC, Noordwijk, The Netherlands, 19-21 November 2002.
- [28]. Magnani PG., Re E., "Robotics and technology aspects of the Rosetta Drill, Sample and Distribution System", Proc. ASTRA'98, November 1998 .
- [29]. Mänttari, M, "Laboratory scale rock drillability tests", Licentiate thesis, Helsinki university of technology, 1997
- [30]. Pang, S.S., Goldsmith, W., Hood, M., "A Force-Indentation Model for Brittle Rocks", Rock Mech. Rock. Eng. vol. 22, pp. 127-148, 1989.