

Gurujal Water Conservation Project

Aditya Kapur

The Shri ram school, Aravali.

Date of Submission: 25-11-2022

Date of Acceptance: 06-12-2022

1. Objectives of this Project
2. Source of water for Haryana
3. Water Scarcity in Gurgaon and How Serious Is the Problem
4. Household Water Audit & Findings. Does my household contribute to the water shortage problem?
5. A Water Survey among residents of our building. Net Findings
6. Understanding Water Consumption for my residential complex and Water Bills
7. Water Flow Schematic for my residential complex
8. Waste Water Management for my residential complex
9. My Recommendations to reduce water usage and encourage recycling within each apartment
10. Macro Recommendations to maximize building water efficiency

11. Potential socio behavioural and economic challenges in the process of implementing the recommendations
12. Early results- June 2020- June 2021

1. The Objectives of the project are as follows:

- 1) To create awareness amongst school children about water scarcity and how serious a problem it is in Gurgaon
- 2) Various methods for households to reduce, recycle and conserve water
- 3) Scalable recommendations to maximize water efficiency in residential buildings and implement the learnings in other buildings

2. Source of water for Haryana

Source of Water for Haryana: Western Yamuna Canal

Proposed: Sutlej-Yamuna Link Canal

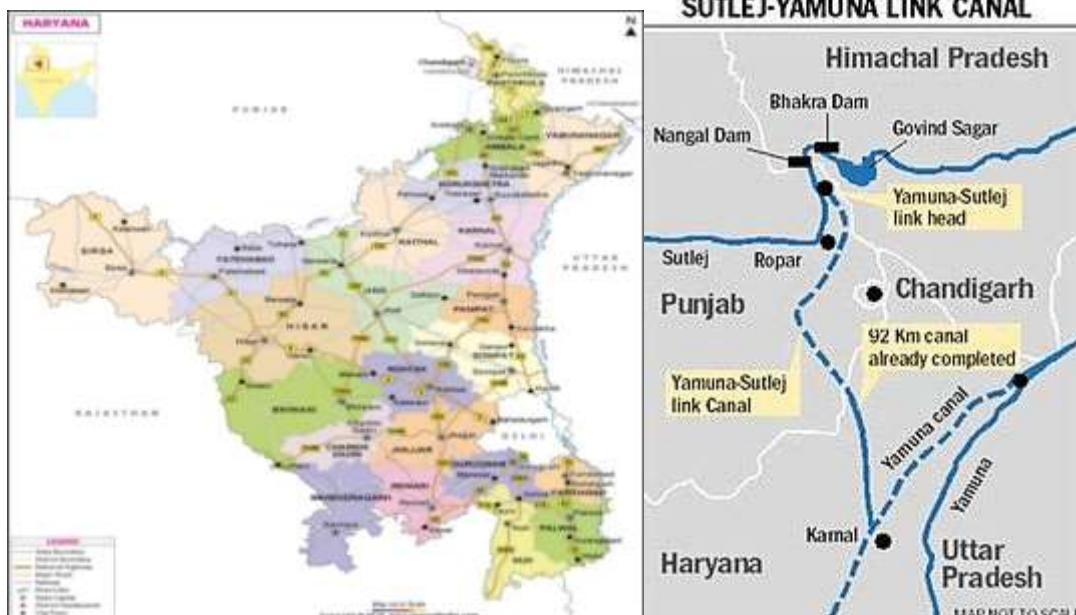

3. Water Scarcity in Gurgaon and How Serious Is the Problem

THE ECONOMIC TIMES News

English Edition | 31 August, 2021, 05:03 PM IST | E-Paper

Gurgaon on its deathbed: Haphazard model of development causes severe water crisis

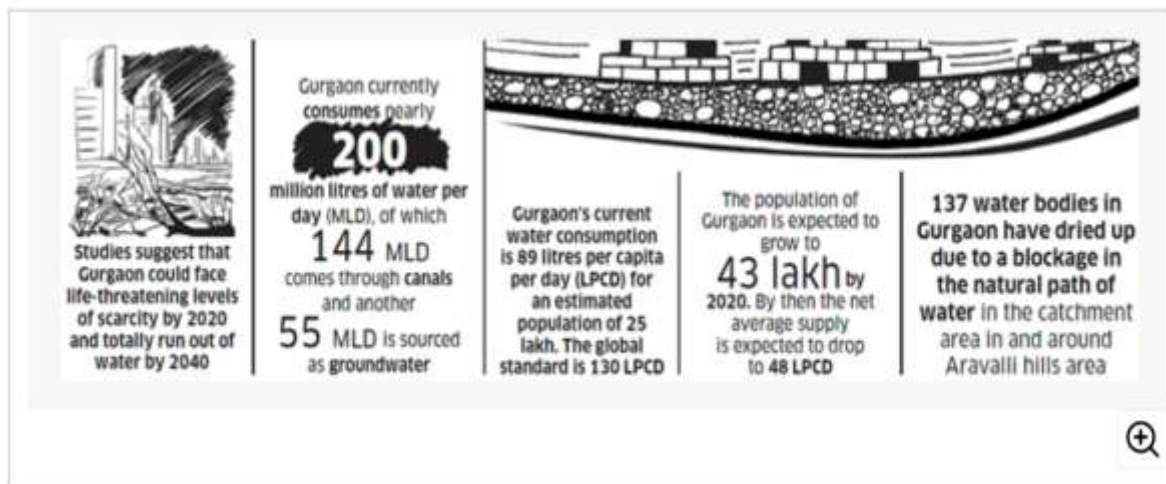

Source: <https://economictimes.indiatimes.com/news/economy/infrastructure/gurgaon-on-its-deathbed-haphazard-model-of-development-causes-severe-water-crisis/articleshow/29728053.cms>

GURUGRAM NEWS

Covid crisis may push city into water crisis this summer: Irrigation dept



By Prayag Arora-Desai, Gurugram

PUBLISHED ON APR 13, 2020 11:03 PM IST



Source: <https://www.hindustantimes.com/gurugram/covid-crisis-may-push-city-into-water-crisis-this-summer-irrigation-dept/story-TAGX3pSTKccPAsdJimJvIN.html>

Gurugram: Water scarcity hits Palam Vihar colony, private tanker operators make a gold

Delhi



Mirror Now Digital
Updated Apr 16, 2021 | 22:27 IST



The residents of the Palam Vihar Colony in Gurugram also alleged that builders in the area are using potable water for construction purposes.

Source:

<https://www.timesnownews.com/delhi/article/gurugram-water-scarcity-hits-palam-vihar-colony-private-tanker-operators-make-a-gold/746103#:~:text=Gurugram%3A%20Palam%20Vihar%20area%20in,by%20a%20severe%20water%20crisis.&text=for%20several%20weeks,-,The%20residents%20of%20many%20blocks%20claimed%20they%20are%20getting%20the,of%20negligence%20towards%20their%20problems>

4. Household Water Audit & Findings. Does my household contribute to the water shortage problem?

How much water does Haryana Government allocate per person per day?

With rapid urbanization and increasing population, demand for water has increased many fold in India in last two decades. It is projected that by 2022 India will become the most populous country in the world. As of 2011 Census of India, there are 46 metropolitan cities, having a population of over 1 million and above; and 8 mega-cities viz. Mumbai, Delhi, Bangalore, Hyderabad, Ahmedabad, Chennai, Kolkata, & Surat, having a population more than 4 million. Renewable water availability below 2,000 cum/person/year is taken as an indicator of water scarcity and India is already in the danger zone. While agriculture amounts to approx. 55% of gross water usage, the domestic water usage is approx. 34%. Residential and Business Buildings account for more than 80% of the domestic water use on annual basis. Ministry of Environment and Forests, Govt. of India mandated Environment Impact Assessment as pre-requisite for sanctioning of large construction projects by all states in 2005 and water conservation norms with special emphasis on use of treated wastewater for non-potable applications became mandatory. However, there is still lack of

clarity on water consumption norms with various codes and reference manuals being practiced e.g IS codes, CPHEEO manuals and local state byelaws. **The domestic water consumption for a community exceeding 1,00,000 population with flush toilets is projected as 150-200 Litres per capita per day (LPCD).** For a business building the water consumption has been fixed at 45 LPCD. All government buildings now need to be at least GRIHA 3 star rated projects. With emphasis on water conservation in building usage and ban on use of fresh water for construction, flushing, irrigation and industrial cooling, it is time to relook in the water consumption norms also. Indian metro utilities water losses in transmission is approximately 40% plus while the same in progressive Asian states like Singapore and Japan is less than 5%. It needs to be understood that one of the major problems in India is not physical scarcity of water rather continuing poor water management. Requirement of the day is to rationalize the water consumption norms, smart metering, smart water distribution, regulations on water pricing, reuse and maintenance. It is important to develop a framework towards optimizing the water consumption norms to realistic consumption which shall have positive impact on management of water utilities in Indian Metro Cities.

Source: Water Consumption Norms and Utilities Management

My Household

We are a household of 4 adults and 2 children and live in an apartment in Uniworld City, Sector 30, Gurgaon. I conducted a water audit for our household.

Water Consumption in different taps and showers within our house:



Note: All units mentioned are in Litres (L).

Taps/ Shower Head names and dimensions:

Taps- Kohler beam Pillar Tap. Dimensions- 9.6 x 6.3 x 6.1 cm

Shower Heads- Jaguar- 6.6 inch

Tap in toilet 1- 2.60 L per minute

Tap in toilet 2- 6.75 L per minute

Tap in kitchen 3- 8.50 L per minute

RO in kitchen 3- 2.75 L per minute

Shower in toilet 1- 12 L per minute

Shower in toilet 2- 9 L per minute

Observations:

- 1) Large variance in water output across different taps and showers in the house
- 2) All flushes in our house are dual system. However, we were not educated on how to use the dual system to save water
- 3) We use freshwater in our flushes
- 4) RO generates waste water, that can be collected and reused
- 5) We use freshwater to wash our clothes, floors and water our plants
- 6) Aerators can be used in our home taps to reduce water flow
- 7) No water meters installed to measure home consumption
- 8) No separate water bill. It is part of maintenance bill.

5. A Water Survey among residents of our building. Net Findings

Understanding Water Consumption in UWC Survey:

I had sent an online form (attached in Appendix A) to 31 out of 576 apartments in the building and the goal was the following-

Survey Methodology:

- a) 30 apartments out of approximately 576 apartments i.e. 5%
- b) Average household of 4-5 people
- c) Since it's the same building the socio-economic level of people is similar
- d) I will also send it to the Estate office and RWA governing body to understand their mindset

Survey Objective:

1. To understand if the residents are aware of a water problem in Gurgaon and its severity?
2. To understand a household's water consumption pattern?
3. Is the household consumption controlled/water sensitive or uncontrolled/no regard for water consumption?
4. Household's water recycling initiatives, if any.
5. Do they want to play an active part in the solution towards conserving water?

Summary of the survey conducted in UWC-

In total 31 residents filled the 'Understanding Water Consumption' survey.

The Conclusion-

- 1) On an average, there are 4 people living in each house
- 2) 22/31 residents think there is a water crisis in Gurgaon

- 3) Majority of the people feel there will be zero 24/7 water supply in another 5 years
- 4) Most of the residents typically have a shower for 1-5 minutes
- 5) While soaping themselves, the residents turn off the tap
- 6) Every resident turns off the tap while brushing their teeth
- 7) 28/31 houses have dual system flushes whereas the other 3 houses have single flush system
- 8) Each resident is aware of pressing the right button after use
- 9) 20/31 houses reuse water
- 10) These residents reuse water by using the waste RO water for mopping the floors, washing fruits and vegetables, utensils and mopping the floor.
- 11) Half of the residents are not aware of the fact we use freshwater for washing cars
- 12) Most of the people know that we use recycled water for watering the plants in the building
- 13) Majority of the residents feel we should have water meters installed per house to measure their water consumption
- 14) Each resident thinks we should limit the use of Ground water and save water in the building
- 15) Almost every resident would like to play a proactive role in conserving water at home and in the building

6. Understanding Water Consumption for my residential complex and Water Bills

Water Consumption in the building from July 2018 to June 2020:

Sr. Number	Month	Borewell Total per month in KL	Huda Total per month in KL	Remarks	Total consumption of water per month	Total consumption of water per day in KL
1.	Jun-2018	21,171	8,489	40%Huda without new pipe	29,660	989
2.	Jul-2018	17,802	5,917	32%Huda	23,719	791
3.	Aug-2018	17,285	8,906	55%Huda	26,191	873
4.	Sep-2018	6682	12,728	50%Huda	19,410	647
5.	Oct-2018	4,252	12,309	70%Huda	16,561	552
6.	Nov-2018	2,147	10,470	82%Huda	12,617	421
7.	Dec-2018	1,736	10,541	85%Huda	12,277	409
8.	Jan-2019	2,330	8,436	81%Huda	10,766	359
9.	Feb-2019	5,716	12,360	68%Huda	18,076	603
10.	Mar-2019	4,795	11,114	72%Huda	15,909	530
11.	Apr-2019	2,475	12,828	81%Huda	15,303	510
12.	May-2019	4,011	11,932	73%Huda	15,943	531
13.	Jun-2019	2,142	11,221	81%Huda	13,363	445
14.	Jul-2019	5,245	10,370	73%Huda	15,615	520
15.	Aug-2019	7,698	12,286	64%Huda	19,984	666
16.	Sep-2019	6,221	12,327	71%Huda	18,548	618
17.	Oct-2019	7,132	11,688	62%Huda	18,820	627
18.	Nov-2019	3,520	13,613	79%Huda	17,133	571
19.	Dec-2019	5,955	10,595	64%Huda	16,550	552
20.	Jan-2020	10,305	6,373	38%Huda	16,678	556
21.	Feb-2020	17,294	8,245	42%Huda	25,539	851
22.	Mar-2020	3,022	9,757	76%Huda	12,779	426
23.	Apr-2020	1,166	9,938	99%Huda	11,104	370
24.	May-2020	2,362	9,313	80%Huda	11,675	389

25.	June-2020	1,040	11,216	92%Huda	12,256	409
-----	-----------	-------	--------	---------	--------	-----

Source: Estate Manager, Uniworld City

Observations/ Data Analysis for building:

- 1) No consistent usage. Large variance in certain months
- 2) There should be no usage of Borewell water
- 3) Average government recommendation= 150-200 LPCD (Litre per Capita per Day)

Total number of apartments= 576
 Average number of residents per apartment= 4
 Total residents at 100% occupancy= 576 x 4= 2304

Theoretical water consumption per resident per day= 175
 Theoretical water consumption of all flats= 2304 x 175= 40,3200=

402KL per day per apartment with 4 people

- 4) Assuming all common areas and lawn water consumption comes from the 300KL per day STP. Hence, recycled water is used for this
- 5) Out of 25months data, only 3 months meet target consumption and 22 months are over

Common Area Water Usage Observations:

- 6) Cars are washed with freshwater even though waste water piping infrastructure exists
- 7) What should STP be as per norms. Our building has a 300 KL STP and 3 buildings have no STP
- 8) We have 4 rainwater harvesting pits. No management over site

Water Bill for December- 2019

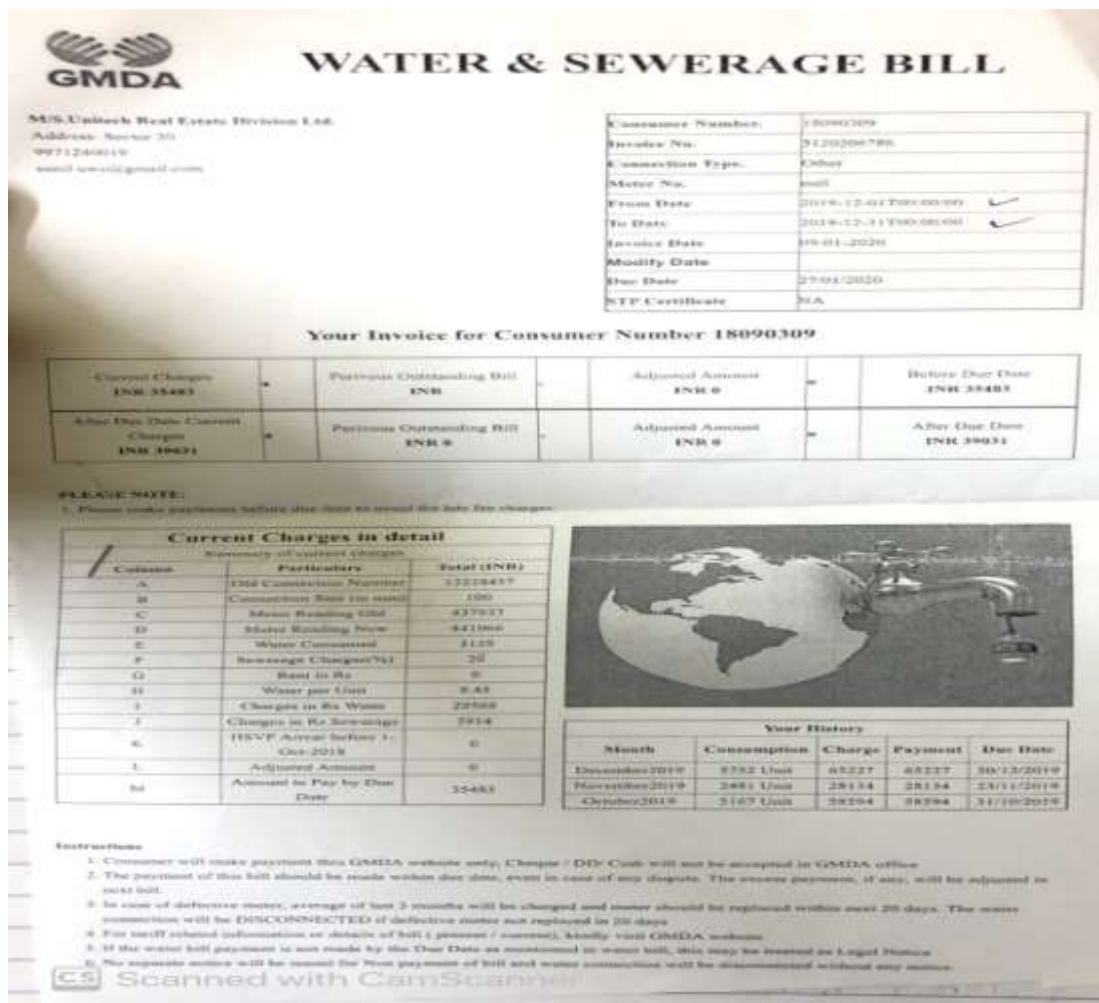

GMDA WATER & SEWERAGE BILL

M/S. Uniworld Real Estate Division Ltd.
 Address: Sector 30
 9971240119
 email: uniworld@gmail.com

Consumer Number:	18090309
Invoice No.:	9129309796
Connection Type:	Other
Meter No.:	Null
From Date:	2019-12-01 00:00:00 ✓
To Date:	2019-12-31 00:00:00 ✓
Invoice Date:	09-01-2020
Modify Date:	
Due Date:	27-01-2020
STP Certificate:	NA

Your Invoice for Consumer Number 18090309

Current Charges INR 35483	Previous Outstanding Bill INR 0	Adjusted Amount INR 0	Before Due Date INR 35483
After Due Date Current Charges INR 19021	Previous Outstanding Bill INR 0	Adjusted Amount INR 0	After Due Date INR 39031

Current Charges in detail

Category	Particulars	Total (INR)
A	104 Connection Number	3228437
B	Connection Fee (in hand)	100
C	Meter Reading Fee	437937
D	Meter Reading Fee	441966
E	Water Consumed	2125
F	Sewerage Charges(%)	20
G	Band in Rs	0
H	Water per Unit	0.43
I	Charges in Rs Water	22569
J	Charges in Rs Sewerage	7914
K	HSVP Arrear before 1- Oct-2019	0
L	Adjusted Amount	0
Rs	Amount to Pay by Due Date	35483

Year History

Month	Consumption	Charge	Payment	Due Date
December 2019	5762 Unit	85227	85227	30/12/2019
November 2019	2483 Unit	28134	28134	28/11/2019
October 2019	2167 Unit	28294	28294	31/10/2019

Instructions:

1. Consumer will make payment thru GMDA website only, Cheque / DD/ Cash will not be accepted in GMDA office
2. The payment of this bill should be made within due date, even in case of any dispute. The amount payment, if any, will be adjusted in next bill.
3. In case of defective meter, average of last 3 months will be charged and meter should be replaced within next 20 days. The water connection will be DISCONNECTED if defective meter not replaced in 20 days.
4. For tariff related information or details of bill (person / account), kindly visit GMDA website.
5. If the water bill payment is not made by the Due Date as mentioned in water bill, this may be treated as Legal Notice.
6. No separate notice will be issued for Non payment of bill and water connection will be disconnected without any notice.

Scanned with CamScanner

Water Bill for May- 2020



GMDA

M/S. Unibest Real Estate Division Ltd.
 Address: Sector 311
 9471240078
 unibest@gmail.com

WATER & SEWERAGE BILL

Consumer Number.	18090309
Invoice No.	13620209624
Connection Type.	Other
Meter No.	null
From Date	2020-05-01T00:00:00
To Date	2020-05-31T00:00:00
Invoice Date	13-06-2020
Modify Date	
Due Date	30/06/2020
STP Certificate	NA

Your Invoice for Consumer Number 18090309

Current Charges INR 39430	Previous Outstanding Bill INR	Adjusted Amount INR 0	Before Due Date INR 39430
After Due Date Current Charges INR 43373	Previous Outstanding Bill INR 0	Adjusted Amount INR 0	After Due Date INR 43373

PLEASE NOTE:
 1. Please make payments before due date to avoid the late fee charges.

Current Charges in detail

Column	Particulars	Total (INR)
A	Old Connection Number	12228437
B	Connection Size (in mm)	100
C	Meter Reading Old	464954
D	Meter Reading New	468421
E	Water Consumed	3477
F	Sewerage Charges(%)	20
G	Rent in Rs	0
H	Water per Unit	9.45
I	Charges in Rs Water	32858
J	Charges in Rs Sewerage	6572
K	HSVP Arrear before 1-Oct-2018	0
L	Adjusted Amount	0
M	Amount to Pay by Due Date	39430



Your History				
Month	Consumption	Charge	Payment	Due Date
May2020	14606 Unit	209062	163632	01/06/2020
March2020	3477 Unit	39430	0	30/04/2020
February2020	5805 Unit	65828	65828	28/02/2020

Instructions

- Consumer will make payment thru GMDA website only, Cheque / DD/ Cash will not be accepted in GMDA office
- The payment of this bill should be made within due date, even in case of any dispute. The excess payment, if any, will be adjusted in next bill.
- In case of defective meter, average of last 3 months will be charged and meter should be replaced within next 20 days. The water connection will be DISCONNECTED if defective meter not replaced in 20 days
- For tariff related information or details of bill (present / current), kindly visit GMDA website
- If the water bill payment is not made by the Due Date as mentioned in water bill, this may be treated as Legal Notice
- No separate notice will be issued for Non payment of bill and water connection will be disconnected without any notice.

CS Scanned with CamScanner

Observations:

- 1) Individual homes do not have water meters
- 2) The Bill is for the whole building
- 3) Significant amount of water is taken out from the Borewells for which no bill is generated

7. Water Flow Schematic for my residential complex

Underground Uniworld City, Water Flow Schematic:

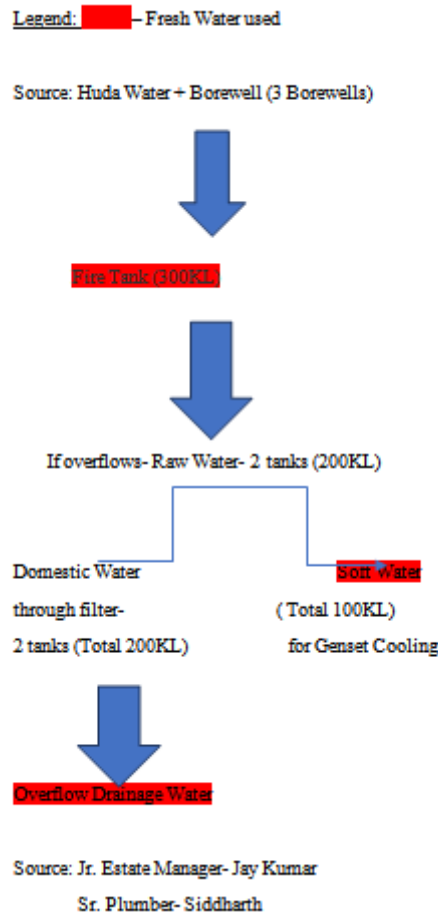

Details:

- 1) Borewell- 3 Borewells:
 - i) Groundwater 160 feet or 49 metres

- ii) Added a new 20-foot pipe last year
- iii) Water reducing year over year

2) Building Tank Planning:

Sr Number	Tower	Type of Tank	Total consumption
1.	A1	Fire Tank	60KL-40KL
2.	A1	Domestic Tank	50KL-60KL
3.	A2	Fire Tank	60KL-40KL
4.	A2	Domestic Tank	50KL-60KL
5.	A3	Fire Tank	40KL-60KL
6.	A3	Domestic Tank	50KL-60KL
7.	B1	Fire Tank	60KL-40KL
8.	B1	Domestic Tank	50KL-60KL
9.	B2	Fire Tank	40KL-60KL
10.	B2	Domestic Tank	50KL-60KL
11.	B3	Fire Tank	40KL-60KL
12.	B3	Domestic Tank	50KL-60KL

13.	C1	Fire Tank	50KL-60KL
14.	C1	Domestic Tank	60KL-50KL
15.	C2	Fire Tank	60KL-60KL
16.	C2	Domestic Tank	60KL-50KL
17.	E1	Fire Tank	50KL-50KL
18.	E2	Domestic Tank	40KL-40KL
19.	F1	Fire Tank	40KL-40KL
20.	F1	Domestic Tank	50KL-50KL
21.	F2	Fire Tank	50KL-50KL
22.	F2	Domestic Tank	40KL-40KL

i) The Water Tanks are cleaned once a year in the month of February

C) Flat Water Inlet:

- i) 4 Water inlets are installed in each flat through the shafts
- ii) Install 4 Kranti Water meters to measure water consumption

iii) PRV installed in each flat

D) Rainwater Harvesting Pits:

- i) There are currently 4 Rainwater Harvesting Pits in the building
- ii) The depth of the pits are 130 feet (40 metres)
- iii) They are cleaned 2 weeks prior to the monsoon season



Types of Recycled Water:

1) Grey water- It is all the wastewater generated in households or office buildings from streams without fecal contamination

Examples of Grey Water in the house-

- i) Sources of grey water include sinks, showers, baths, washing machines or dishwashers.

Q1) Is Grey Water captured in the building?

A1) The Grey Water in our building is first treated by the STP then it is recycled by watering the plants. We can also recycle this water by washing cars and changing the bathroom water. We can also wash our clothes and mop the floor with the help of this water.

2) Black Water- Blackwater is the mixture of urine, feces and flush water.

Examples of Black Water in the house-

- i) Blackwater contains water from the toilet

Q1) Is Black Water captured in the building?

A1) The Black Water directly goes to the STP and after being treated, it is used for watering plants.

Dark Zones- Are areas demarcated by the government where the over-exploitation of groundwater is acute, and where the withdrawal and usage of water exceeds its recharge.

What Zone does Haryana come into- Haryana is staring at a severe water crisis with the groundwater depleting at a rapid rate and completely drying up in some areas, leading to the alarming emergence of 12 'dark zones. A zone is termed to be 'over-exploited' if the pumping out of the underground water exceeds 100 per cent. The underground water level has plunged by 20-60 metres in 19 of the 22 districts

What Zone does Gurgaon come into- The district's hydrology department says the groundwater level has reached a "dark zone", which, according to officials, is 20 metres below

the surface in north India. The groundwater table has sunk to about 45 to 50 metres in parts of DLF City, Sohna Road and Sector 56 due to a high concentration of residential complexes. The situation could get worse as dozens of upscale condominiums are coming up

Role of the Haryana Government in the crisis- The Haryana government has launched a pilot project encouraging farmers to go for pigeon peas (arhar) or maize cultivation, crops which require relatively lesser amounts of water. The state government has announced a subsidy for those who opt for crops other than paddy

8. Waste Water Management Scheme:

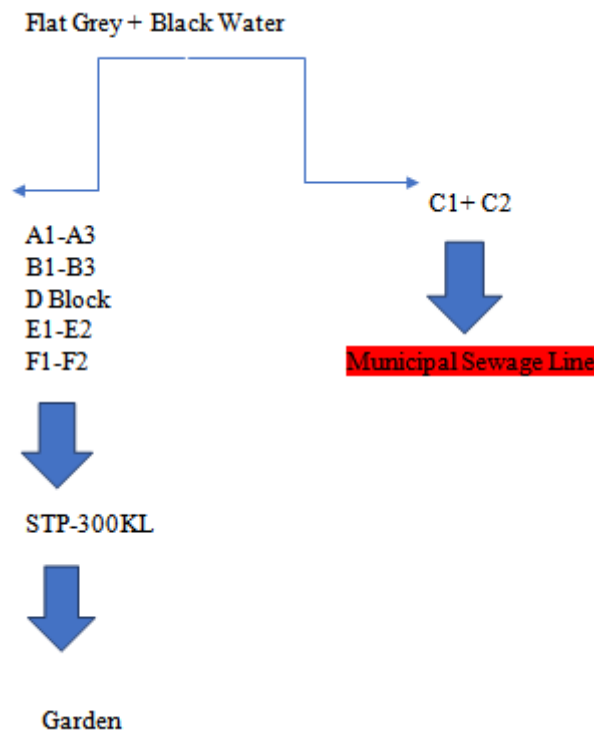

- There is 1 Fire Tank located in the basement of the building. Its capacity is 300KL



- There are 2 Raw Water Tanks located in the basement of the building. The total capacity is 200KL



- There are 2 Domestic Water Tanks located in the basement of the building. The total capacity is 200KL

9. My Recommendations to reduce water usage and encourage recycling within each apartment:

- 1) Student Involvement Plan-
 - Create awareness in apartments by making a group of children/teenagers the brand ambassadors of the building who would not only conduct meetings, informing the residents about the seriousness of water scarcity but also act as role models and thus, inspire others to conserve water.

In apartments:

- Reduce water- by installing aerators in every tap of the house and having bucket water baths instead of long showers. Installing water-saving shower heads or flow restrictors to minimise the wastage of water would also help.
- Recycle- by collecting the waste RO water in a bucket and watering our plants, washing our utensils or even giving our pets a bath.
- Turning the water taps off during brushing etc.

- 2) Outside the apartments-
 - Educating the staff members about water scarcity

- Collecting the waste water via the STP and clean the cars and water the garden
- Installing water meters in every tower to track the water consumption in a month

10. Macro Recommendations to maximize building water efficiency:

- Educating the staff members about water scarcity
- Collecting the waste water via the STP and use it to water the garden
- Attach a new colour coded pipe, connected to the STP, for washing cars
- Connecting Tower C1 and C2's water pipe directly to the STP and not sewage
- Installing water meters in every tower to track the water consumption in a month
- Have a 0 Borewell plan, to minimise the water taken out from the Borewell's and instead supply water from Huda tankers

Our achievements:

- 1) Majority of the residents are aware of the water problem in Gurgaon and have understood its severity

- 2) Based on the questions, we concluded that majority of the residents have a bath for 1-5 minutes and they are water sensitive as they switch the taps of while soaping themselves/ brushing. They frequently reuse their RO waste water by washing utensils and other household materials.
- 3) Every resident would like to play a proactive role by reduce the water consumption in their houses and also the building.

11. Early Results:

From June 2020 to June 2021, 8 out of 13 months(July-2020,Sep-2020,Oct-2020,Nov-2020,Dec-2020,Jan-2021,May-2021,Jun-2021) have followed the Haryana Government's allocation of water per day as the building has consumed either 402 KL per day or below after following the various methods and practises recommended in this document.

Sr. Number	Month	Borewell Total per month in KL	Huda Total per month in KL	Remarks	Total consumption of water per month	Total consumption of water per day in KL
1	June-2020	1,040	11,216	92%Huda	12,256	409
2	Jul-2020	2041	6815	70%Huda	8,856	286
3	Aug-2020	25	13572	100%Huda	13,597	439
4	Sep-2020	0	6595	100%Huda	65,95	200
5	Oct-2020	330	9649	97% Huda	9,979	322
6	Nov-2020	0	10886	100%Huda	10,886	330
7	Dec-2020	3144	4225	26% Huda	7,369	238
8	Jan-2021	2218	7645	71% Huda	9,863	318
9	Feb-2021	2795	9776	71% Huda	12,571	449
10	Mar-2021	1163	13532	91% Huda	14,695	474
11	Apr-2021	1420	13532	90% Huda	14,952	453
12	May-2021	1560	8959	83% Huda	10,519	339
13	Jun-2021	1580	3033	48% Huda	4,613	140

Trends:

We notice that in months (June-2020, Aug-2020, Nov-2020, Feb-2020, March-2021, April-2021), not only do we source more water from Huda Tankers but also take out a significant amount of water out from the Borewells.

Water is reducing in the summer months, as the Huda line was damaged and hence, all the water was sourced from the Borewell. In Sep-2020 and Nov-2020, the Borewell consumption was 0 as the Huda Tankers were completely functional. Generally, the GMD gives a 2 day notice to the building that water sourced from Huda will be minimised and hence, the building is required to source their water from the Borewells.

Having a 0 Borewell plan would be the key solution to having consistent numbers and water flow. Fixing the Huda line would definitely be beneficial to the society and would also prevent consuming water from the Borewells.

Source: Estate Manager, Uniworld City