

# Implementation of Boolean Function Using Electrons

Aditya

Submitted: 10-08-2022

Revised: 22-08-2022

Accepted: 24-08-2022

## ABSTRACT :

The problem is that we have only transistors as the source of information processing.

We can achieve the pace of doubling the information, speed much faster without the requirement of transistor.

If we take electrons trapped with the help of Single-Electron Transistor (SET) and use Stern-Gerlach Experiment to find the spin then we can make NAND Gate and hence, an ALU (Algorithmic Logical Unit) which is the main logic behind the micro-processor.

## INTRODUCTION :

We trap the electrons using 'Single-electron transistor' (SET).

A single-electron transistor:

The SET transistor can be viewed as an electron box that has two separate junctions for the entrance and exit of single electrons (figure 4). It can also be viewed as a field-effect transistor in which the channel is replaced by two tunnel junctions forming a metallic island. The voltage applied to the gate electrode affects the amount of energy needed to change the number of electrons on the island.

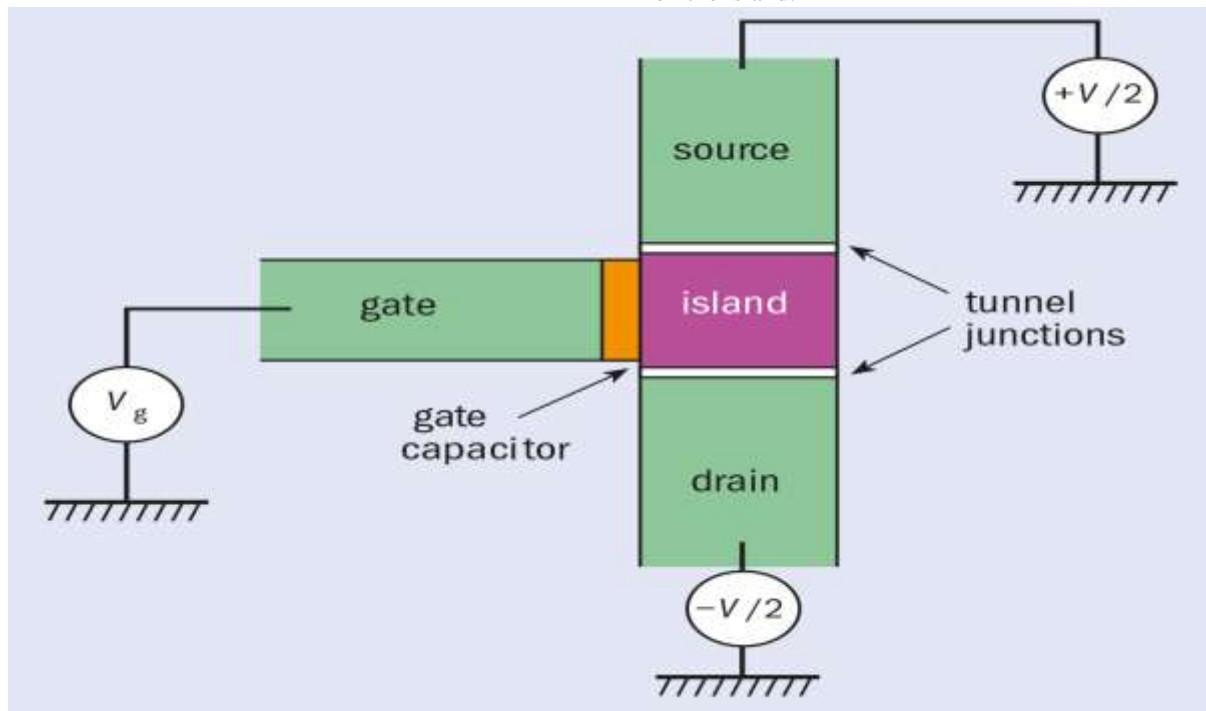

Principle of the SET transistor: The SET consists of a gate electrode that electrostatically influences electrons travelling between the source and drain electrodes. However, the electrons in the SET transistor need to cross two tunnel junctions that form an isolated conducting electrode called the island. Electrons passing through the island

charge and discharge it, and the relative energies of systems containing 0 or 1 extra electrons depends on the gate voltage. At a low source-drain voltage, a current will only flow through the SET transistor if these two charge configurations have the same energy.

The SET transistor comes in two versions that have been nicknamed “metallic” and “semiconducting”. These names are slightly misleading, however, since the principle of both devices is based on the use of insulating tunnel barriers to separate conducting electrodes.

In the original metallic version fabricated by Fulton and Dolan, a metallic material such as a thin aluminium film is used to make all of the electrodes. The metal is first evaporated through a shadow mask to form the source, drain and gate electrodes. The tunnel junctions are then formed by introducing oxygen into the chamber so that the metal becomes coated by a thin layer of its natural oxide. Finally, a second layer of the metal – shifted from the first by rotating the sample – is evaporated to form the island.

In the semiconducting versions, the source, drain and island are usually obtained by “cutting” regions in a two-dimensional electron gas formed at the interface between two layers of semiconductors such as gallium aluminium arsenide and gallium arsenide. In this case the conducting regions are defined by metallic electrodes patterned on the top semiconducting layer. Negative voltages applied to these electrodes deplete the electron gas just beneath them, and the depleted regions can be made sufficiently narrow to allow tunnelling between the source, island and drain. Moreover, the electrode that shapes the island can be used as the gate electrode.

In this semiconducting version of the SET, the island is often referred to as a quantum dot, since the electrons in the dot are confined in all three directions. In the last few years researchers at the Delft University of Technology in the Netherlands and at NTT in Japan have shown that quantum dots can behave like artificial atoms. Indeed, it has been possible to construct a new periodic table that describes dots containing different numbers of electrons (see “Quantum dots” by Leo Kouwenhoven and Charles Marcus Physics World June pp35-39).

Step 2: Then we use Stern-Gerlach Experiment to know the spin of the electrons.

Some details:

The Stern–Gerlach experiment involves sending a beam of silver atoms through an inhomogeneous magnetic field and observing their deflection.

The results show that particles possess an intrinsic angular momentum that is closely analogous to the angular momentum of a classically spinning object, but that takes only

certain quantized values. Another important result is that only one component of a particle's spin can be measured at one time, meaning that the measurement of the spin along the z-axis destroys information about a particle's spin along the x and y axis.

The experiment is normally conducted using electrically neutral particles such as silver atoms. This avoids the large deflection in the path of a charged particle moving through a magnetic field and allows spin-dependent effects to dominate.

If the particle is treated as a classical spinning magnetic dipole, it will precess in a magnetic field because of the torque that the magnetic field exerts on the dipole (see torque-induced precession). If it moves through a homogeneous magnetic field, the forces exerted on opposite ends of the dipole cancel each other out and the trajectory of the particle is unaffected. However, if the magnetic field is inhomogeneous then the force on one end of the dipole will be slightly greater than the opposing force on the other end, so that there is a net force which deflects the particle's trajectory. If the particles were classical spinning objects, one would expect the distribution of their spin angular momentum vectors to be random and continuous. Each particle would be deflected by an amount proportional to its magnetic moment, producing some density distribution on the detector screen. Instead, the particles passing through the Stern–Gerlach apparatus are deflected either up or down by a specific amount. This was a measurement of the quantum observable now known as spin angular momentum, which demonstrated possible outcomes of a measurement where the observable has a discrete set of values or point spectrum.

Although some discrete quantum phenomena, such as atomic spectra, were observed much earlier, the Stern–Gerlach experiment allowed scientists to directly observe separation between discrete quantum states for the first time in the history of science.

Theoretically, quantum angular momentum of any kind has a discrete spectrum, which is sometimes briefly expressed as “angular momentum is quantized”.

Step 3:

We use Magnetic field to change the spin of the electrons, since magnetic field consists of photons. If a photon collides with an electron, we know that spin must be conserved. Let's assume the electron is in a spin up state  $\uparrow e = +1/2$  and the photon in a spin down state  $\downarrow p = -1$ . There are two possibilities if these two meet:

$\uparrow e \rightarrow \uparrow e$  to  $\uparrow e \rightarrow \uparrow e$  and  $\downarrow P \rightarrow \downarrow P \downarrow P \rightarrow \downarrow P$  which means no spin flip  
 or  
 $\uparrow e \rightarrow \downarrow e$  to  $\uparrow e \rightarrow \downarrow e$  and  $\downarrow P \rightarrow \uparrow P \downarrow P \rightarrow \uparrow P$ , which is possible because  $+1/2 - 1 = -1/2$

Step 4: Let's say the spin of the electrons is  $+1/2$  and the input instruction given to the experiment setup is  $-1/2$  then the magnetic field will change the spin to  $-1/2$  and then the information will be send to the converter which will send a signal further with low current output. If the information form the

other setup is  $+1/2$  then the converter will send the signal further with high current output will read 0 for  $-1/2$  and 1 for  $+1/2$  and will give the output as 1 according to the calibration done.

A B C  
 0 0 1  
 0 0 1  
 0 1 1  
 1 0 1  
 1 1 0

Similarly, we can do with other cases and covert the spins to computer readable bits.

FIGURES :

