

The Rotordynamics Analysis of the Washing Machine Shaft Supported By Passive Magnetic

¹Praveen.C.Bhajantri, ²K.D.Kattimani

¹Student, KLS Gogte Institute of Technology, Belagavi.

²Assistant Professor, KLS Gogte Institute of Technology, Belagavi.

Submitted: 05-06-2021

Revised: 18-06-2021

Accepted: 20-06-2021

ABSTRACT: These are various parameters over which the performance of the shaft and bearing depends. This paper deals with a different parameters and specification of the shaft and bearing to find out the optimized model. Based on the Finite element method the model analysis Campbell and harmonic analysis has been performed.

In now days high speed and high precision is the requirement of any rotating machinery. Ball Bearing are the main element used for rotating application such as machinery. The permanent magnetic bearing [PMB] are contact less or levitation there is a no contact with stator and rotor. And it is a less magnetic resistance, less noisy and no heat generation.

This project work presents the comparison between deep groove ball bearing and permanent magnetic bearing. All the analysis is performed in ANSYS WORKBENCH 16.1

KEYWORDS:

Deep groove ball bearing, Passive magnetic bearing, shaft, Modal analysis, Campbell diagram.

I. INTRODUCTION

Bearings are used to support rotating elements commonly used in machines that controls relative motion and reduces friction between moving parts. And also there are different types of bearings which are used in mechanical applications such as roller bearings and ball bearings. Ball bearings are subdivision Deep groove ball bearings, Self Aligning ball bearings, Angular Contact ball bearings, Thrust ball bearings. And roller bearings are subdivision Tapered Roller bearings, Spherical Roller bearings, Cylindrical Roller bearings, Needle Roller bearings. The bearings are used to reduce the friction between rotating parts the various research work are carried out for friction reduction in bearing and design improvement. In ancient time peoples were using wheels for reducing friction and after day by day invented various methods for friction reduction. Leonardo da vinci they developed ball bearings and they designed for a helicopter and they carried out different experiment for static friction of sliding parts. In this project permanent magnetic bearings [PMB] is designed to compare permanent magnetic bearing with deep groove ball bearings

1.1 DEEP GROOVE BALL BEARING



Fig 1.1 Deep Groove Ball Bearing

A deep groove ball bearing is a type of rolling element bearing that uses balls to maintain the clearance between the bearings. The main purpose of a ball bearing is to support loads and

reduce rotational frictions. These type of deep groove ball bearing are commonly used in machines vehicles etc.

1.2 MAGNETIC BEARING

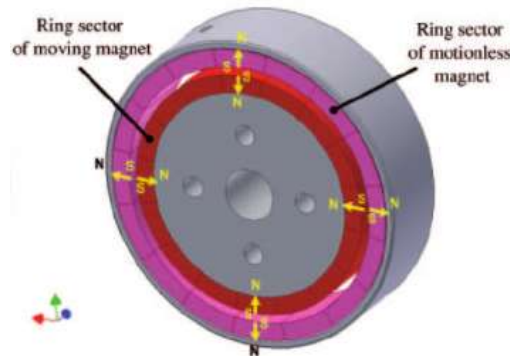

Fig 1.2 Magnetic Bearing

There are two types of magnetic bearings active controlled magnetic bearing and passive type permanent magnetic bearing [PMB]. Magnetic bearing are commonly used for rotating application and also these are contactless. And first permanent magnetic bearing [PMB] was prepared in glenn research center. And permanent magnetic bearing does not required any kind of electronics device or external power to generate. In permanent magnetic bearing [PMB] the repulsive force which acts due to magnets placed on both rotor and stator. Due to stator magnet and magnetic ring repulsive force will acts and magnetic ring will be in levitate in air. And these type of magnetic bearings are commonly used in maglev trains to get low noise and smooth ride and used in industrial machines such as turbo molecular pump, turbo compressor, ultra centrifuges and also used in space technology (satellite), terrestrial application, energy storage flywheel and

used in watt-hour meter to measure home power consumption.

1.3 WASHING MACHINE SHAFT AND BEARINGS NOMENCLATURE

1. **WASHING MACHINE SHAFT** :- Washing machine shaft generally constitute of disc and bearings.
2. **DISC** :- This is a part of the shaft which is fixed to the end of the shaft for transfer motion to the disc (drum).
3. **BEARINGS** :- This is a parts where installed in the shaft.
4. **OFFSET** :- This is a space between bearings and disc.

1.4 OBJECTIVES

The objective of the project is to do “The rotordynamic analysis of the washing machine shaft supported by passive magnetic bearing”

1.5 METHODOLOGY

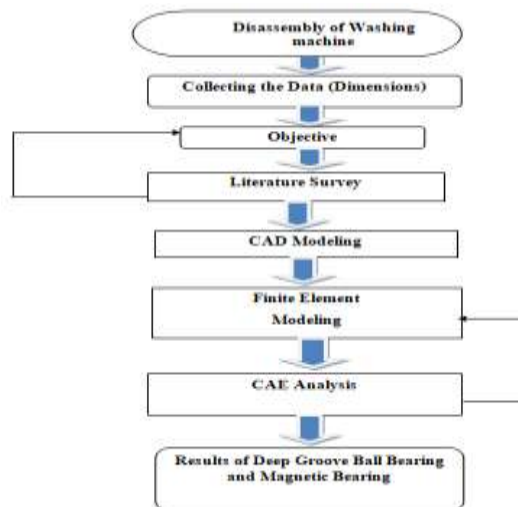

Fig 1.2 Methodology

II. LITERATURE REVIEW

Literature review is carried out for my project is to compare between deep groove ball bearing and passive type permanent magnetic bearing [PMB]. Design this review we find out magnetic bearing is having a capable to operate without lubrication and less magnetic resistance

Paper 1 :- Permanent magnetic bearing [PMB] for spacecraft applications.

Robert fusaro and wilfredo :- They have done design and operate passive permanent magnetic bearing [PMB] ring for spacecraft, terrestrial applications. The permanent magnetic bearing [PMB] are operated is such way that it will be in repulsive mode for radial support and also permanent magnetic bearing [PMB] designed, construct, and testing for satellite application.

Paper 2 :- Passive Magnetic Bearing.

Hamler, B. Stumberger, V. Gori and Can, Jesenik, M. Trlep :- They have carried work on permanent magnetic bearing [PMB] and they have developed permanent magnetic bearing [PMB] for both the case axial load and radial load in both direction by axially magnetized permanent magnets.

Paper 3 :- Rotor Dynamics of Passive magnetic Bearing [PMB] System.

H. ming chen, Scott wheeler, Thomas waiter, Nga Lee :- They have carried work on rotor dynamic of a permanent magnetic bearing [PMB] system. And also they have developed permanent magnetic bearing [PMB] for space energy storage systems[satellite], Terrestrial applications. By using permanent magnetic bearing [PMB] they performed spin test it was operated to 66000rpm.

[15] **AnandkumarTelang** The system having two bearings permanent magnetic bearing [PMB] and active radial damper also. They measured radial stiffness for bearing its around 263N/mm and load capacity around 65N and remnant flux density of permanent magnetic bearing [PMB] is around 1.0 tesla. And they have used active radial damper instead using an radial bearing to replace one of the permanent magnetic bearing [PMB] means active radial damper doesn't take any radial load. And without damper permanent magnetic bearing [PMB] bearing will not be in stable. And also they concluded that radial bearings system are efficient in power consumption and easy to control.

Paper 4 :- Solution of contact free passive magnetic bearings.

Daniel Mayer, Visit Verely :- They also carried out work on contact free passive magnetic bearing with solution. And also professional programs are used for analysis of magnetic field and it is possible to solve the magnetic bearing. And

they found out different ways for improve the qualities of magnetic bearings.

Paper 5 :- S.C Mukhopadhyay G. Sen Gupta. C. Gooneratne :- They also carried out work on magnetic bearings. This paper deals with different forms of a repulsive type magnetic bearing system which is used as an group platform for learning and teaching. And also they have carried out work on different components of a hybrid magnetic bearings model they have used JJ instruments for measuring the repulsive force. They concluded few subjects for improvement of permanent magnetic bearing [PMB] such as electromagnetic, electronics microcontroller, control system, sensing technology etc [11] **Siebert.**

Paper 6 :- Reduce – Friction for Passive Magnetic Bearings.

Guillaume Filion, Jean Recel and Maxime R. Dubais :- They carried out work on Passive permanent magnetic bearing [PMB] for reducing – Friction. They have also design permanent magnetic bearing [PMB] for flywheel energy storage system. The main objective is a study of permanent magnetic bearing [PMB] for minimizes of energy losses produced by the axial thrust bearing. And they have been concluded that magnets used in the bearings has a limited influence on the damping ratios [14] **J. Sandtner.**

[17] **S. Saravanan,** In these paper they have carried out work on frictional torque on a rotating disc. They have performed project on measurement on an aluminium disc which is installed on they bearing that is gives an initial twist and allowed to spin until if comes to stop.

[12] **Y. Regamey, J. Sandtner** Carried out his work on the reduction of friction using passive magnetic bearings. They have designed and developed passive permanent magnetic bearings for (FESS) flywheel energy storage system and measurement of stiffness and damping.

[20]. **Paden, B.,** Design and test results have been performed for a passive magnetic bearing system including two magnetic bearing are active magnetic radial damper and active magnetic thrust bearings and Permanent magnetic [PM] radial bearings. Active magnetic radial bearings are simple in control and efficient power consumption. Permanent magnetic [PM] radial bearing used for high-speed rotors for flywheels application.

2.1 FUTURE SCOPE

The data collected from the washing machine shaft and bearing before and after installing the passive magnetic bearings need to be compared

**III. BEARING STIFFNESS
 CALCULATIONS FOR DEEP
 GROOVE BALL BEARING**

Horizontal axis washing machine consist a shaft of length 144mm with 2 deep groove ball

bearing on the shaft. The nomenclature and the specification of the bearing is as follows
 Bearing number: 6205-C3H ORS.
 Bearing number: 6203-C3 ORS.



Fig 3.1 shaft with bearing assembly

3.1 PROPERTIES OF MATERIALS.

Mass of the disc is 3.6kg

3.1.1 PROPERTIES OF DEEP GROOVE BALL BEARING MATERIAL

MATERIAL	DENSITY (Kg/m ³)	YOUNGS MODULUS (MPa)	POISSON'S RATIO
STRUCTURAL STEEL	7850	2×10^5	0.3

Table no 3.1 Properties of Deep Groove Ball Bearing Material

3.1.2 PROPERTIES OF PERMANENT MAGNETIC BEARING MATERIAL

MATERIAL	DENSITY (Kg/m ³)	YOUNGS MODULUS (MPa)	POISSON'S RATIO
N35 NdFeB	7500	160×10^3	0.24

Table no 3.2 Properties of Permanent Magnetic Bearing Material

3.2 TECHNICAL SPECIFICATIONS OF THE DEEP GROOVE BALL BEARING

3.2.1 BEARING NUMBER: 6205-C3H ORS.



6205 Deep groove ball bearings

Profil Item:
 SKF Explorer

Deep groove ball bearings

Bearing data

Tolerances:
 Normal (metric), P6, P5, Normal (inch),
 Radial internal clearance:
 Matched bearing pairs, Stainless steel

Bearing interfaces

Seat tolerances for standard
 conditions,
 Tolerances and resultant fits

Fig 3.2 Bearing number 6205-C3H ORS

a) DIMENSIONS

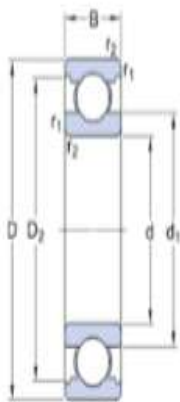

d	25 mm
D	52 mm
B	15 mm
d ₁	≈ 34.35 mm
D ₂	≈ 46.21 mm
r _{1,2}	min. 1 mm

Fig 3.3 Dimensions

b) ABUTMENT DIMENSIONS

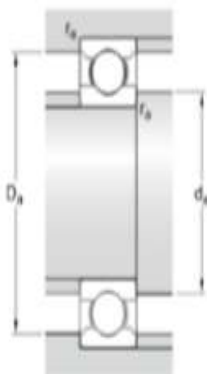

d _a	min. 30.6 mm
D _a	max. 46.4 mm
r _a	max. 1 mm

Fig 3.4 Abutment Dimensions

c) CALCULATION DATA

Basic dynamic load rating C 14.8 Kn

Basic static load rating C0 7.8 kN

Reference speed 28 000 r/min

Limiting speed 18 000 r/min

Calculation factor kr 0.025

Mass bearing 0.13 kg

d) CALCULATION

The calculation for bearing stiffness is considered from a journal paper by Gargiulo, E.P., Jr., A Simple Way to Estimate Bearing Stiffness, Machine Design, 1980, pp.107-110 the formula is as follows

Deep- Groove Ball Bearing or Angular – Contact Radial Ball Bearings

$$K = 0.0325 E06 \sqrt[3]{DFZ^2 \cos^5 \alpha}$$

K- Radial stiffness (Lbf/in)

D – Ball diameter (in)

Z- Number of Rolling Elements

F- External Radial Force (Lbf)

α - Contact angle (rad)

Sl.No	Parameter	Values in metric system		Values in English system	
1	D	7.9 mm		0.311024 in	
2	Z	11		11	
3	F	Dynamic load rating	Static load rating	Dynamic load rating	Static load rating
		14.02 KN	7.88 KN	3151.8214Lbf	1771.494Lbf
4	α	Contact angle is considered to be zero for deep groove ball bearing			

Table no 3.3 Specification of Bearing

➤ Minimum Radial stiffness considering static load rating

$$K = 1317820.767 \text{ Lbf/in}$$

$$K = 230785.77 \text{ N/mm}$$

➤ Maximum Radial stiffness considering dynamic load rating

$$K = 1596848.269 \text{ Lbf/in}$$

$$K = 279650.98 \text{ N/mm}$$

3.2.2 BEARING NUMBER: 6205-C3H ORS.



Fig 3.5 Bearing Number 6205-C3H ORS

a) DIMENSIONS



d	17 mm
D	40 mm
B	12 mm
d ₁	= 24.5 mm
D ₂	= 34.98 mm
r _{1,2}	min. 0.6 mm

Fig 3.6 Dimensions

b) ABUTMENT DIMENSIONS



d ₁	min. 21.2 mm
D ₁	max. 35.8 mm
r ₁	max. 0.6 mm

Fig 3.7 Abutment Dimensions

c) CALCULATION DATA

Basic dynamic load rating 9.95 kN
 Basic static load rating 4.75 Kn
 Reference speed 38 000 r/min
 Limiting speed 24 000 r/min
 Calculation factor kr 0.025
 Mass bearing 0.065 kg

Way to Estimate Bearing Stiffness, Machine Design, 1980, pp.107-110 the formula is as follows
 Deep- Groove Ball Bearing or Angular – Contact Radial Ball Bearings

$$K = 0.0325 E06 \sqrt[3]{DFZ^2 \cos^5 \alpha}$$

K- Radial stiffness (Lbf/in)
 D – Ball diameter (in)
 Z- Number of Rolling Elements
 F- External Radial Force (Lbf)
 α - Contact angle (rad)

d) CALCULATION

The calculation for bearing stiffness is taken from a published paper by Gargiulo, E.P., Jr., A Simple

Sl.No	Parameter	Values in metric system		Values in English system	
1	D	7.3mm		0.287402 in	
2	Z	9		9	
3	F	Dynamic load rating	Static load rating	Dynamic load rating	Static load rating
		9.55 KN	4.76 KN	2146.925Lbf	1070.091 Lbf

4	α	Contact angle is considered to be zero for deep groove ball bearing
---	----------	---

Table no 3.4 Specification of Bearing

➤ Minimum Radial stiffness considering static load rating

$$K = 949179.6046 \text{ Lbf/in}$$

$$K = 166226.819 \text{ N/mm}$$

➤ Maximum Radial stiffness considering dynamic load rating

$$K = 1197146.372 \text{ Lbf/in}$$

$$K = 209652.45 \text{ N/mm}$$

Note:

1. Z- Number of balls are assumed through the SKF catalogue

2. D- Diameter of the ball is approximately calculated from fig 2

$$D = D_2 - d_2$$

IV. ASSEMBLY OF SHAFT AND BEARINGS

4.1 EXPLODED VIEW OF WASHING MACHINE SHAFT WITH BEARINGS ASSEMBLY

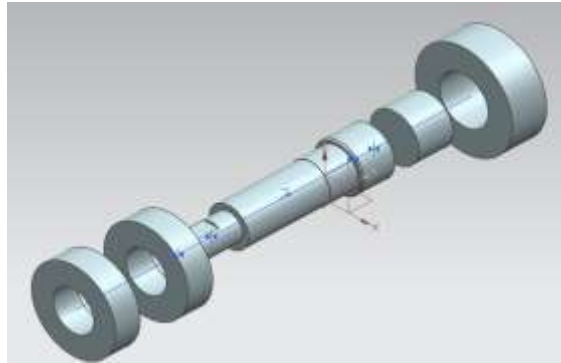

Fig 4.1 Exploded view of of washing machine shaft with bearings assembly

The above figure 4.1 shows that exploded view of the assembly which consists of shaft, bearings, disc and other parts

4.2 ASSEMBLY OF WASHING MACHINE SHAFT WITH DEEP GROOVE BALL BEARINGS.

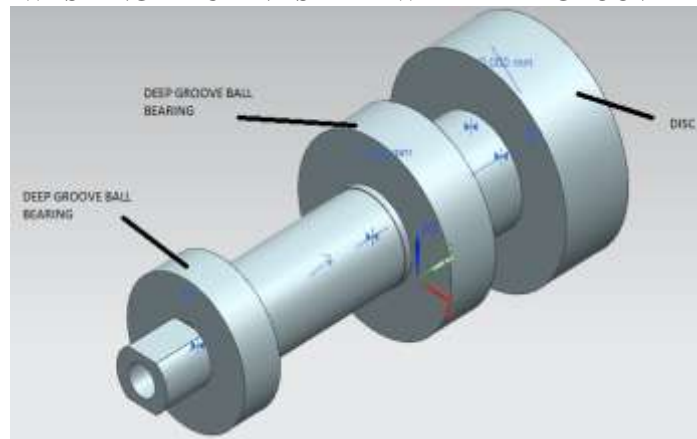

Fig 4.2 Assembly of washing machine shaft with bearings.

The above figure shows that complete assembly of the washing machine shaft with deep groove ball bearings. The modeling of every part of

the assembly was done by keeping in mind all the design features and considerations. And 3D model has been done in NX 12.0. as shown in figure 4.2.

4.3 ASSEMBLY OF WASHING MACHINE SHAFT WITH MAGNETIC BEARINGS ON BOTH SIDES.

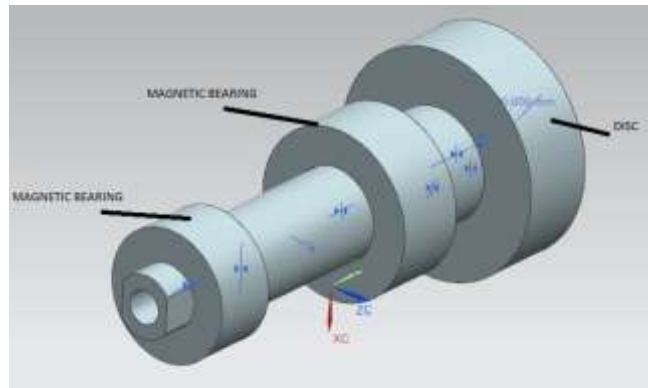

Fig 4.3 Assembly of Washing Machine Shaft with Magnetic Bearings on Both side

The above figure shows that complete assembly of the washing machine shaft with passive magnetic bearings. And we replaced deep groove ball bearing to passive permanent magnetic bearings as shown in figure 4.3.

4.4 ASSEMBLY OF WASHING MACHINE SHAFT WITH MAGNETIC BEARING AND DEEP GROOVE BALL BEARING.

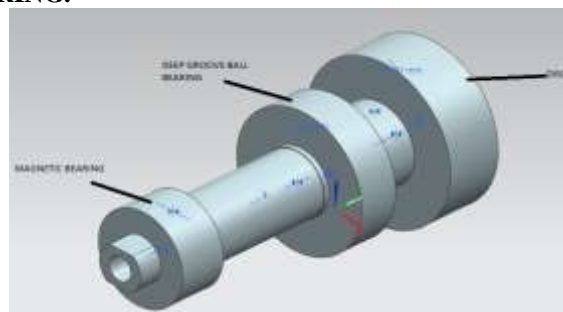

Fig 4.4 Assembly of washing Machine Shaft with Magnetic Bearing and Deep Groove Ball Bearing

The above figure shows that complete assembly of the washing machine shaft with magnetic bearing and deep groove ball bearing. In

these process we replaced one passive permanent magnetic bearing and another one we replaced to deep groove ball bearing only as shown in figure 4.4.

4.5 ASSEMBLY OF WASHING MACHINE SHAFT WITH DEEP GROOVE BALL BEARING AND MAGNETIC BEARING.

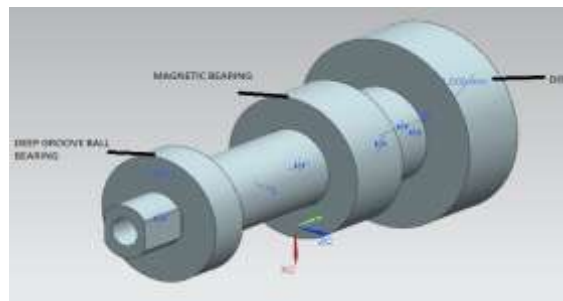

Fig 4.5 Assembly of Washing Machine Shaft with Deep Groove Ball Bearing and Magnetic Bearing

The above figure 4.5 shows that complete assembly of the washing machine shaft with deep groove ball bearing and magnetic bearing. In Fourth

condition we are taking passive permanent magnetic bearing on left end side and in middle we use deep groove ball bearing and in right end it is disc.

V. ANALYSIS RESULTS

6.1 MESHED MODEL ON ANSYS WORK BENCH

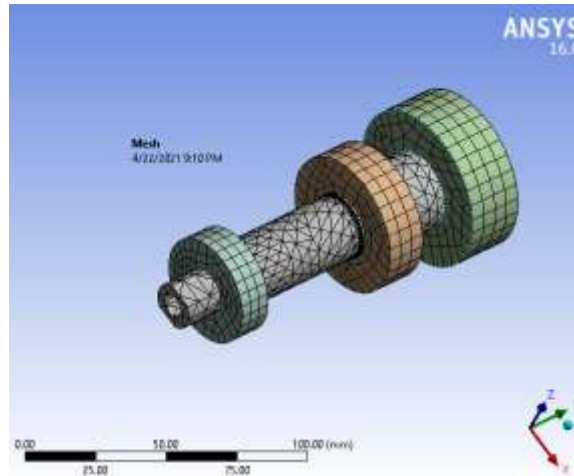

Fig 6.1 Meshed Model on Ansys Workbench 16.0

Meshing is nothing but a computer aided engineering simulation process. And different types of meshing element process have been done for example Tetra element, Hex element, Brick element, Quad element etc. In this process we generated automatic meshing as shown in above figure 6.1.

6.2 CONTACTS

In analysis software parts contacts are very important. In these projects we are having four contacts as shown in below figures.

6.2.1 FRICTIONLESS - MAGNETIC BEARING TO SHAFT

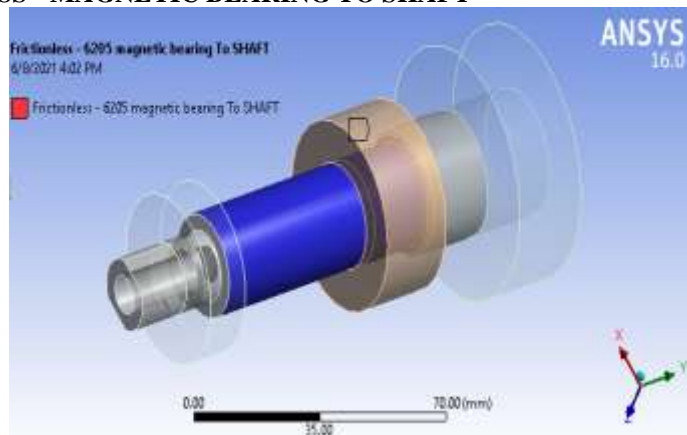

Fig 6.2 Frictionless – Magnetic Bearing to shaft

6.2.2 FRICTIONAL – BEARING 6203 TO SHAFT

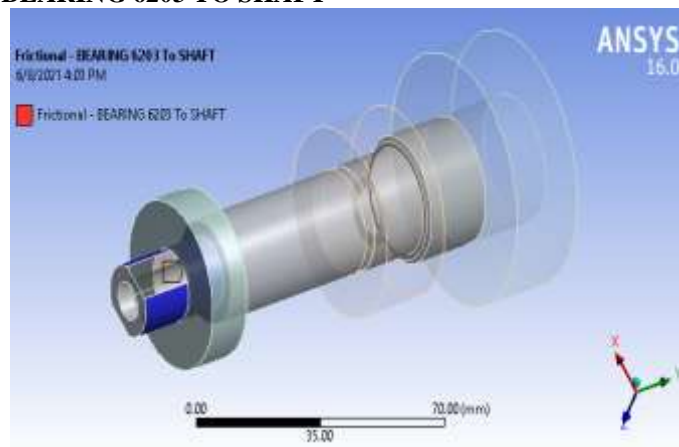

Fig 6.3 Frictional – Bearing 6203 to Shaft

6.2.3 BONDED-DISC TO DISC HOLDER

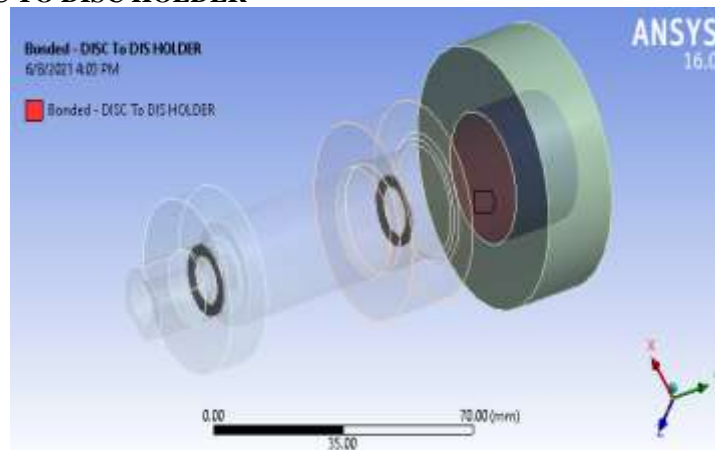

Fig 6.4 Bonded – Disc to Disc Holder

6.2.4 BONDED- DISC HOLDER TO SHAFT

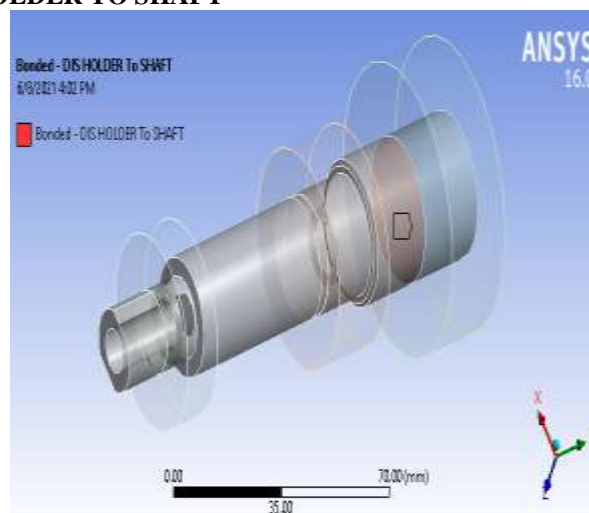

Fig 6.5 Bonded- Disc Holder to Shaft

6.3 BOUNDARY CONDITIONS

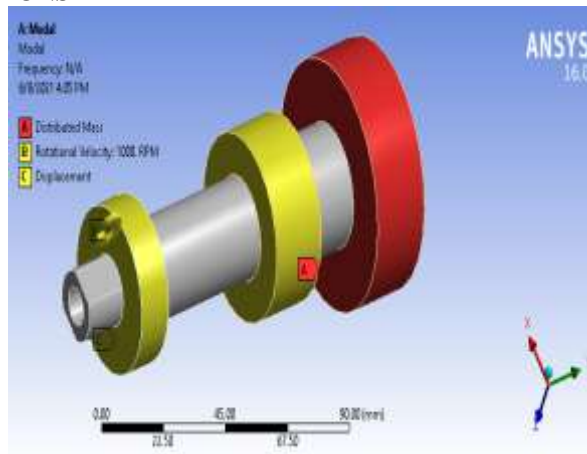

Fig 6.6 Boundary Condition

Boundary conditions are they Distributed mass, Rotational velocity and Displacement. Distributed mass is nothing but a disc weight which is fixed to the right end of shaft and its having

the mass around 3.6kg .Rotational velocity is around 1000RPM speed and Displacement is nothing but a motion of the bearing along a circular shaft as shown in figure 6.6.

6.4 RESULTS OF WASHING MACHINE SHAFT WITH DEEP GROOVE BALL BEARINGS. 6.4.1 Result of total Deformation 1

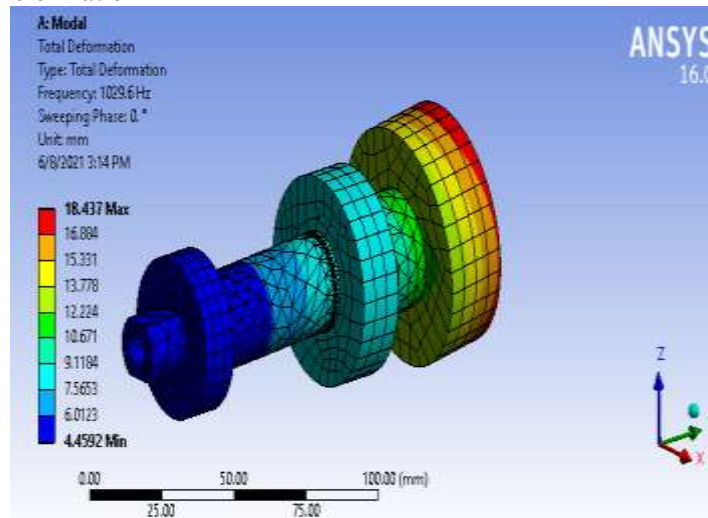

Fig 6.7 Result of total Deformation 1

This is a modal analysis of washing machine shaft with deep groove ball bearing as shown in the above figure 6.7. The maximum

amount of deformation which is occurred on the tip of the disc is around 18.437 max as shown in figure.

6.4.2 Result of total Deformation 2

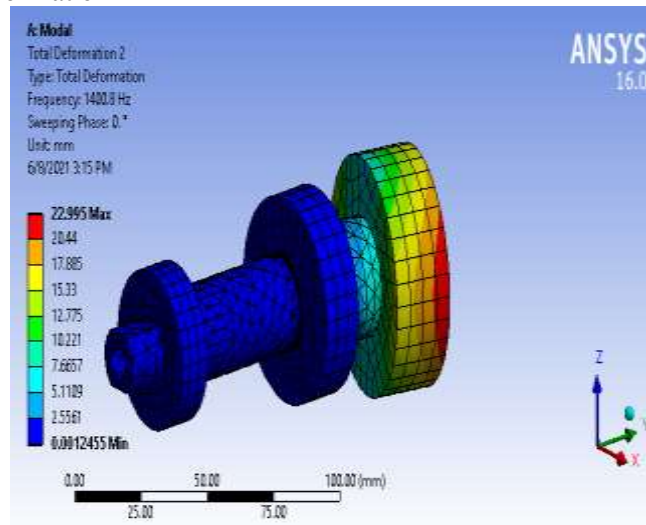

Fig 6.8 Result of total Deformation 2

The maximum amount of deformation which is occurred on the tip of the disc is around 22.995 max as shown in figure 6.8.

6.4.3 Result of total Deformation 3

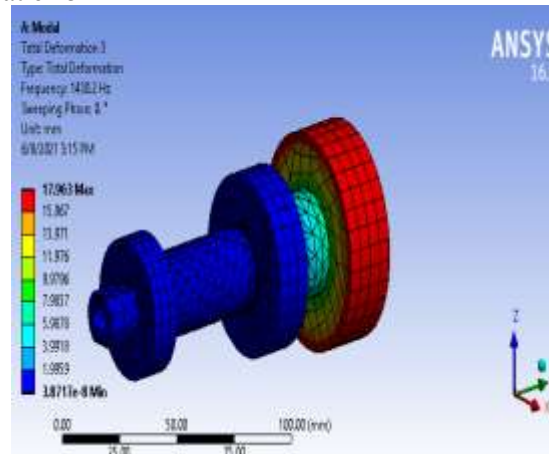

Fig 6.9 Result of total Deformation 3

The maximum amount of deformation which is occurred on the circular disc is around 17.963 max as shown in figure 6.9.

6.4.4 Result of total Deformation 4

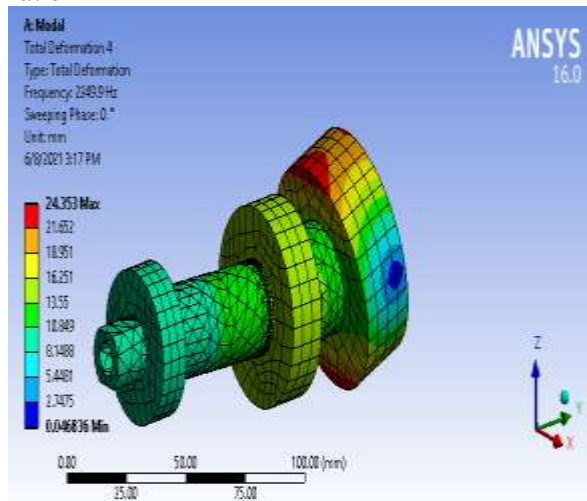

Fig 6.10 Result of total Deformation 4

The maximum amount of deformation which is occurred on the circular disc is around 24.353 max as shown in figure 6.10.

6.4.5 Campbell Diagram

Campbell diagram indicates frequency(Hz) v/s rotational velocity(rpm) graph to measure the

vibration excitation which occurs on the operating system .And also its shows the backward (BW) and forward (FW) indication for example shaft is rotating in clockwise direction and vibration take place in same direction then it's called as forward (FW) and apposite to the clockwise direction means it is backward (BW).

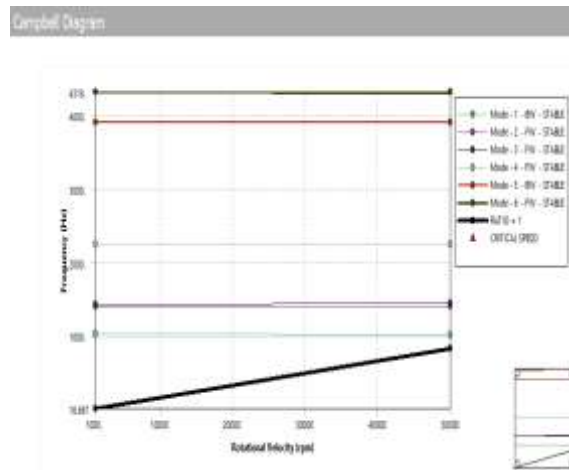

Fig 6.1.1 Campbell Diagram

In these diagram its indicates that it run up to 50000RPM also there is a no problem because bearing are contact between shaft so that there is no

problem of vibration and critical speed indication as shown in figure 6.1.1

6.5 RESULTS OF WASHING MACHINE SHAFT WITH MAGNETIC BEARINGS.

6.5.1 Result of total Deformation 1

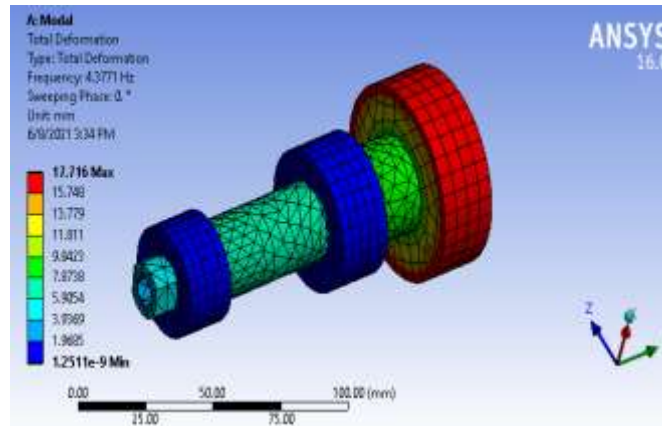

Fig 6.1.2 Result of total Deformation 1

This is a modal analysis of washing machine shaft with permanent magnetic bearing as shown in the above figure 6.1.2. The maximum

amount of deformation which is occurred on the circular disc is around 17.716 max as shown in figure.

6.5.2 Result of total Deformation 2

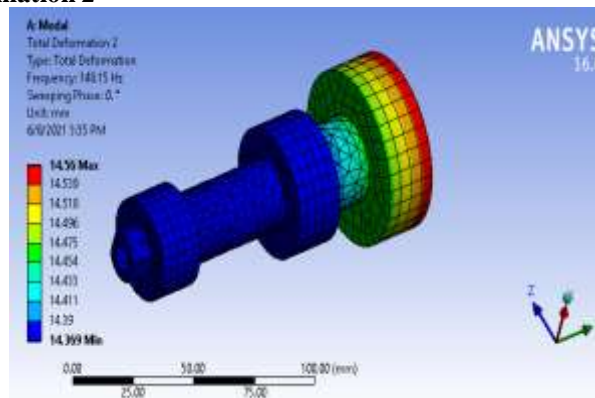

Fig 6.1.3 Result of total Deformation 2

The maximum amount of total deformation which is occurred on the tip of circular disc is around 14.56 max as shown in figure 6.1.3.

6.5.3 Result of total Deformation 3

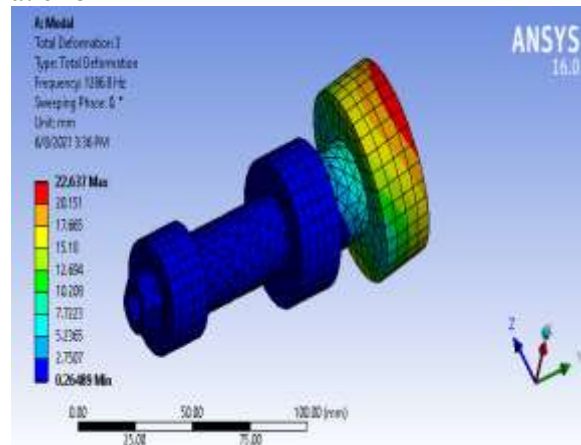

Fig 6.1.4 Result of total Deformation 3

The maximum amount of total deformation 3 which is occurred on the tip of disc is around 22.637 max as shown in figure 6.1.4.

6.5.4 Result of total Deformation 4

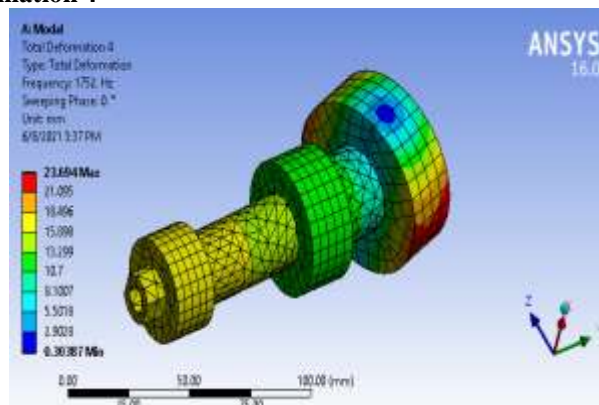

Fig 6.1.5 Result of total Deformation 4

The maximum amount of total deformation which is occurred on the tip of circular disc is around 23.694 and for shaft is around 18.496 max as shown in figure 6.1.5.

6.5.5 Campbell Diagram

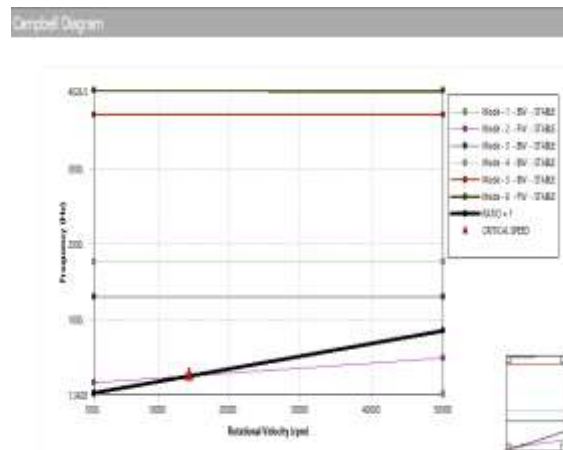

Fig 6.1.6 Campbell Diagram

In these diagram its shows that critical speed is above 18000RPM its shows the indication in red colour arrow mark as shown in figure 6.1.6

6.6 RESULTS OF WASHING MACHINE SHAFT WITH MAGNETIC BEARINGS AND DEEP GROOVE BALL BEARING.

6.6.1 Result of total Deformation 1

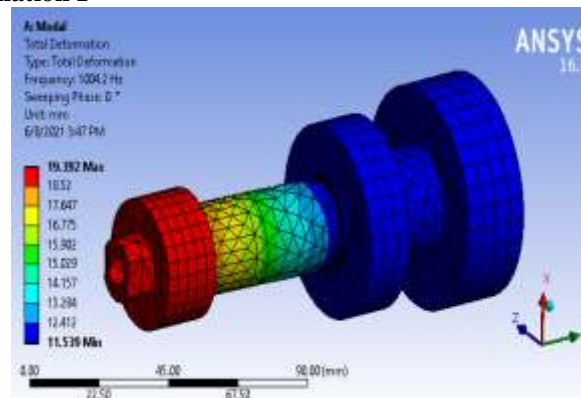

Fig 6.1.7 Result of total Deformation 1

This is a modal analysis of washing machine shaft with permanent magnetic bearing and deep groove ball bearing as shown in the above figure. The maximum amount of total deformation

which is occurred on the end of shaft and magnetic bearing is around 19.392 max as shown in figure 6.1.7.

6.6.2 Result of total Deformation 2

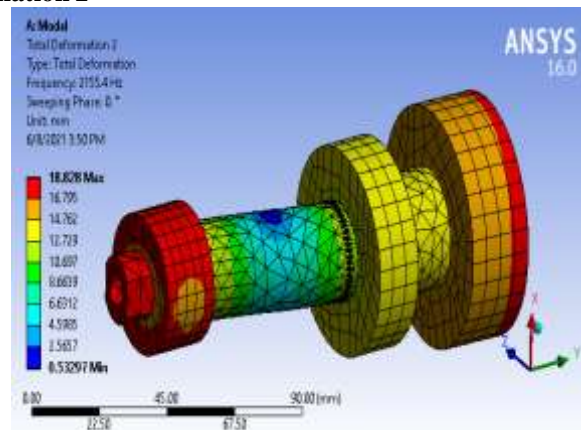

Fig 6.1.8 Result of total Deformation 2

The maximum amount of total deformation which is occurred on the end of shaft and magnetic bearing and also in the disc is around 18.828 max as shown in figure 6.1.8.

6.6.3 Result of total Deformation 3

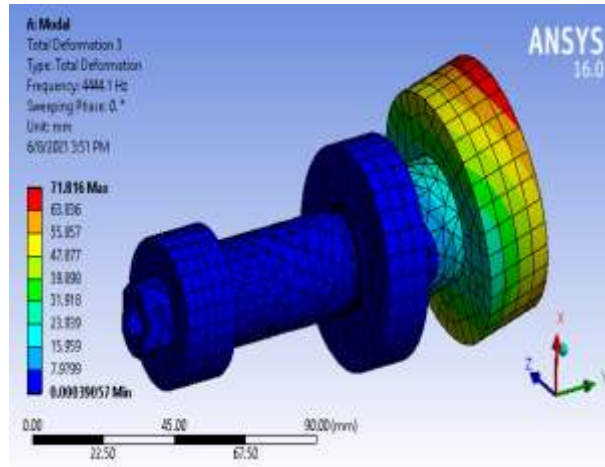

Fig 6.1.9 Result of total Deformation 3

The maximum amount of total deformation which is occurred on the tip of circular disc is around 71.816 as shown in figure6.1.9.

6.6.4 Result of total Deformation 4

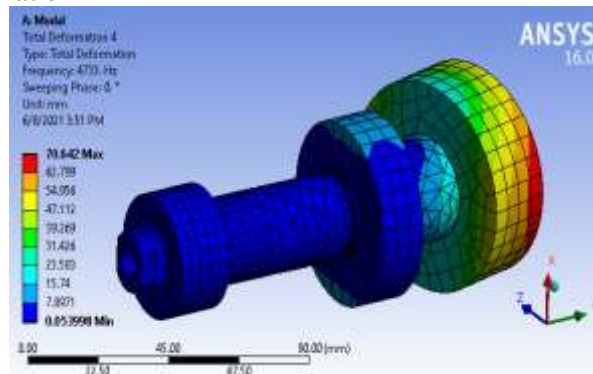

Fig 6.2 Result of total Deformation 4

The maximum amount of total deformation which is occurred on the tip of the circular disc is around 70.642 as shown in figure6.2.

6.6.5 Campbell Diagram

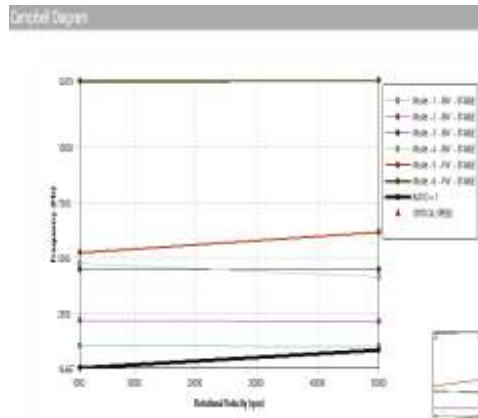

Fig 6.2.1 Campbell Diagram

Campbell diagram shows that in 3rd condition it can run up to 50000 rpm also there is no vibration as shown in figure 6.2

6.7 RESULTS OF WASHING MACHINE SHAFT WITH DEEP GROOVE BALL BEARING AND MAGNETIC BEARING.

6.7.1 Result of total Deformation 1

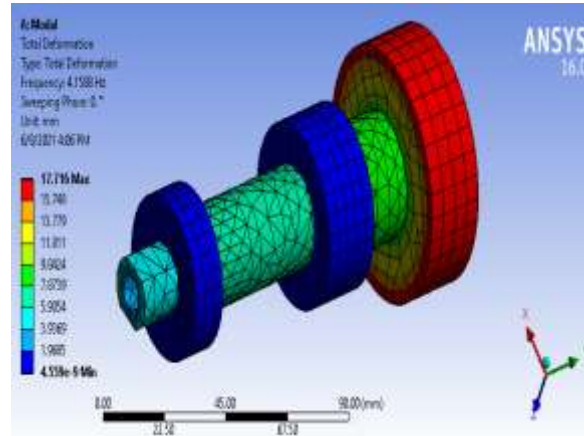

Fig 6.2.2 Result of total Deformation 1

This is a modal analysis of washing machine shaft with deep groove ball bearing and permanent magnetic bearing as shown in the above

figure 6.2.2. The maximum amount of total deformation which is occurred on the entire disc is around 17.716 max as shown in figure 6.2.2.

6.7.2 Result of total Deformation 2

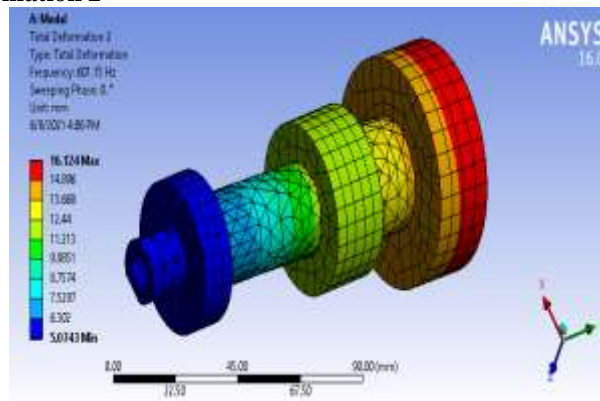

Fig 6.2.3 Result of total Deformation 2

The maximum amount of total deformation which is occurred on the entire tip of the disc is around 16.124 max as shown in figure 6.2.3.

6.7.3 Result of total Deformation 3

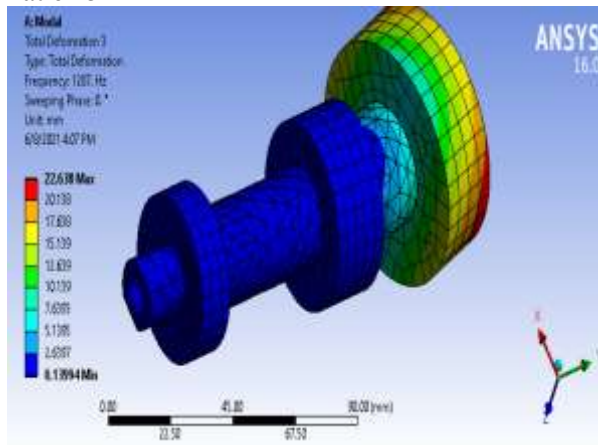

Fig 6.2.4 Result of total Deformation 3

The maximum amount of total deformation which is occurred on the tip of the disc is around 22.638max as shown in figure 6.2.4.

6.7.4 Result of total Deformation 4

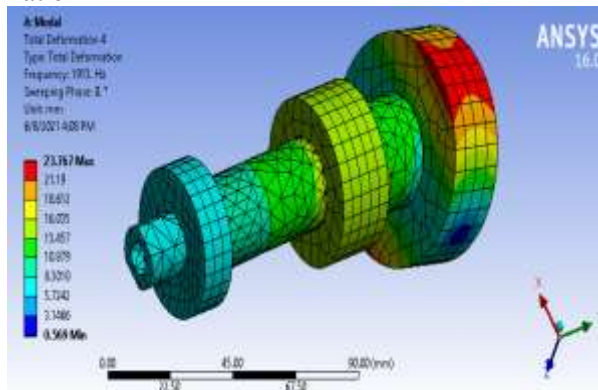

Fig 6.2.5 Result of total Deformation 4

The maximum amount of total deformation which is occurred on the tip of the disc is around 23.767 max and 16.035 for permanent magnetic bearing as shown in figure 6.2.5.

6.7.5 Campbell Diagram

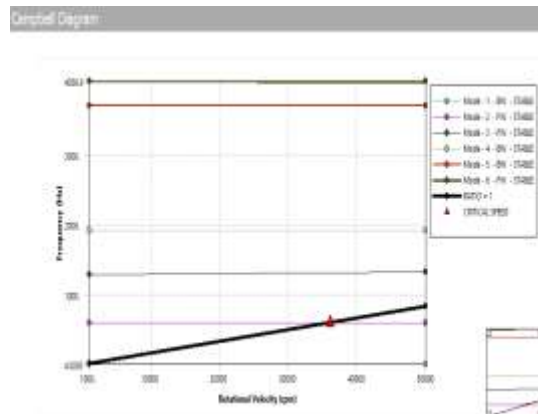

Fig 6.2.6 Campbell Diagram

In 4th case Campbell diagram indicates that it can run up to 36000rpm after that vibration take place as shown in figure

VI. CONCLUSION

The project present the design of washing machine shaft with deep groove ball bearing by studying from various reference papers and I got idea to replace deep groove ball bearing to permanent magnetic bearing. And calculated boundary condition for analysis and I calculated boundary conditions like distributed mass, rotational velocity, displacement and stiffness value etc from given data. And I worked on washing machine shaft and with deep groove ball bearing and permanent magnetic bearing with replacement of permanent magnetic bearing position. And I have done analysis by using software as Ansys workbench 16.1.

And we got good results and we compare the results with replacing deep groove ball bearing to permanent magnetic bearing. By these we concluded that we can reduce the power, friction and contact also between shaft and bearing and surface finish is also improved by using high speed shaft.

REFERENCES

- [1]. Wilfredo Morales and Robert Fusaro, —Permanent magnetic bearing for spacecraft applications| NASA/TM—2003-211996/REV1 (2003).
- [2]. A. Hamler, V. Gori&can, B. Stumberger, M. Jesenik, M. Trlep, —Passive magnetic bearing| University of Maribor, Smetanova, Journal of Magnetism and Magnetic Materials 272–276 (2004) 2379–2380,ELSEVIER(2004)
- [3]. Rohit K. Nakum¹, Bharat S. Patel² and Jayantilal P. Hadiya³- Mechanical Engineering Department, BVM Engineering College-VVNagar, Gujarat, India.
- [4]. Rishikesh B.Kamthe¹, Chetan S.Magdum², Aditya S. Gandhi ³, Pranav A.Naik⁴, Prof. P.D.Gharge⁵ International Journal of Innovative Research in Science, Engineering and Technology (An ISO 3297: 2007 Certified Organization) Vol. 5, Issue 5, May 2016
- [5]. S.C.Mukhopadhyay, C. Gooneratne and G. Sen Gupta Institute of Information Sciences and Technology Massey University (Turitea), Palmerston North New Zealand email : S.C.Mukhopadhyay@massey.ac.nz 2nd International Conference on Autonomous Robots and Agents December 13-15, 2004.
- [6]. Arkadiusz Mystkowski, Leszek Ambroziak[7] carried out his work on Investigation of passive magnetic bearing with halbach-array. Mechanics and control Vol 31 No.1 2012.
- [7]. S.C.Mukhopadhyay, C. Gooneratne and G. Sen Gupta —Magnetic Bearing : An Integrated Platform for Teaching and Learning| Institute of Information Sciences and Technology, new Zealand, 2nd International Conference on Autonomous Robots and Agents, December 13-15, (2004)
- [8]. Book: Machine Design, Authors Dr. P.C. Sharma, D.K. Aggarwal, Publisher, S. K. Kataria & Sons, 1997
- [9]. Source: Wikipedia-bearing, —American Society of Mechanical Engineers (1906), Transactions of the American Society of Mechanical Engineers, 27, American Society of Mechanical Engineers, p. 4411.
- [10]. Siebert, M., Ebihara, B., Jansen, R., Fusaro, R.L., Morales, W., Kasak, A., and Kenny A., 2002, —A Passive Magnetic Bearing Flywheel,| NASA TM–2002-211159, 2002.
- [11]. R. Moser, Y. Regamey, J. Sandtner and H. Bleuler: “Passive Diamagnetic Levitation for Flywheels”, Proc. 8th ISMB (Intern. Symposium on Magnetic Bearing), Mito, Japan, (2002).
- [12]. R. Moser, J. Sandtner and H. Bleuler: “Diamagnetic Suspension Assisted by Electrostatic Actuators”, Proc. of 6th International Symposium on Magnetic Suspension Technology, Torino, (2001).
- [13]. J. Sandtner, H. Bleuler: “Electrodynamic Passive Magnetic Bearing with Planar Halbach Arrays”, Proc. of 9th International Symposium on Magnetic Bearings ISMB9, Lexington, Kentucky, USA, Aug. 3-6, (2004), Paper #5.
- [14]. AnandkumarTelang “Static Stiffness Analysis Of High Frequency Milling Spindle”, International Journal of Research in Engineering and Technology, Assistant Professor, Mechanical Engg Department, BKIT, Bhalki, Karnataka, India, eISSN: 2319-1163.
- [15]. Santosh Arali, V.V.Kulkarni, Analysis Of Cnc Lathe Spindle For Maximum Cutting Force Condition And Bearing Life, International Journal of Innovative Research in Advanced Engineering (IJRAE) PG Student, ISSN: 2349-2163 ,Volume 1 Issue 6 (July 2014).
- [16]. S. Saravanan, G.S. Yadava, P.V. Rao, Condition monitoring studies on spindle

- bearing of a lathe, *Int J AdvManufTechnol* (2006) 28: 9931005, Received: 10 June 2004 / Accepted: 18 October 2004 / Published online: 16 November 2005.
- [17]. Masatsugu MORI, Takuji Kobayashi, "High-Speed Tapered Roller Bearing for Machine Tool Main Spindles", *Ntn Technical Review* No.74 2006, .
- [18]. V.B.Bhandari, *Machine Design*, Tata McGraw-Hill Education, 12th edition.
- [19]. Paden, B., N. Groom, and J. Antaki, "Design formulas for permanent-magnet bearings," *ASME Trans.*, Vol. 125, 734–739, 2003.