

## Touch Free Smart Gadget

Mr.J.Arokiaraj<sup>1</sup>, Ms.R.Priyadharshini<sup>2</sup> Ms.S.Sindhu<sup>3</sup>  
Ms.M.Nandhini<sup>4</sup> Ms.N.Ishwarya<sup>5</sup>,

*Department of EEE ,Kings college of Engineering*

Submitted: 10-03-2021

Revised: 30-03-2021

Accepted: 01-04-2021

**ABSTRACT:** In today's world carrying a number of plastic smartcard to establish our identity has become an integral segment of our routine lives. BIO-METRIC fingerprint systems have a major problem of viral spread among the people. To overcome this problem we come with some new innovative idea that is touch free smart gadget. Wi-Fi Modem is used for tracking and identification purpose. In this paper, the principle aim is to discuss the viability of Touch free smart gadget technology. Our Touch free smart gadget consists of Wi-Fi module for tracking, fingerprint sensor for identification, MEMS sensor to recognize abnormal moment like EPILEPSY, vibration sensor as a reminder and an emergency switch to give alter signal. The additional aim of our system is to propose a viable technological solution for a single multipurpose touch free smart gadget to avoid malfunction or fraud in large companies.

### I. INTRODUCTION:

The present invention relates to the field of Internet of things (IOT) in Smart Identity Card. Recent advancements in smart technologies have led to development of smart card/chip card that comprises embedded chip for several and various purposes. Technologies in this field have developed new ways to use the smart card in every possible day-to-day activity such as credit/debit purchases, visiting libraries, theatres, etc. In our proposed system we developed a touch free smart gadget for university/college /power plant/company purpose.

1. An active RFID present within the identity card.
2. A prepaid system for various transactions within the university/power plant/company.
3. Biometric attendance
4. A prepaid wallet has the individuals' registration number as the account number used for all the transactions.
5. Emergency purpose.

An automatic attendance management system aims at solving the issues of manual

methods of existing systems. A prototype of Smart attendance system based on ESP8266 smart card has been proposed. The concept of Smart attendance is to implement a system that marks the attendance of a particular person within a limited time period. A smart card is a device that includes an embedded integrated circuit chip (ICC) that can be either a secure microcontroller or equivalent intelligence with internal memory or a memory chip alone.

The card connects to a reader with direct physical contact or with a remote contactless radio frequency interface. With an embedded microcontroller, smart cards have the unique ability to store large amounts of data, carry out their own on-card functions (e.g., encryption and mutual authentication) and interact intelligently with a smart card reader. Smart card technology conforms to international standards (ISO/IEC 7816 and ISO/IEC 14443) and is available in a variety of form factors, including plastic cards, fobs, subscriber identity modules (SIMs) used in GSM mobile phones, and USB-based tokens.

### II. EXISTINGSYSTEM:

There are plenty of projects which are going on for the attendance system by different scenario and concepts. In this existing system, attendance system is used only for identification. The existing system largely consists of physical register where the supervisor manually inputs the attendance record of all students.. Other technologies which have been developed to replace this manual system include fingerprint, retina scan, voice recognition etc. The problem with existing system is that the manual system is time consuming and the advanced technologies are too expensive to be implemented on a large scale in any organization.

RFID system is one of the example of existing system,



Radio Frequency Identification is a technology that uses radio wave signals to transfer data from RFID tag, through a RFID reader and process the data embedded on the tag to satisfy the need of a specific application. Usually, RFID tags have a small storage that contains an identification of that tag. Information that can be embedded in the tag are unique identification number, location coordinates or particular data a developer will use in the product being produced. A RFID tag is made of an integrated circuit with an antenna. The tag can allow 2 KB of data. An RFID reader is used to read data stored on the RFID tag. The reader uses radio waves signals antennas to receive signal from RFID tag. RFID technology work by an RFID reader that sends radio wave signals and the RFID tag receives it, the transmit back signal containing data on that tag and then that data provided by the tag will be transformed into digital information to be received by a computer.

It consist following disadvantages

- The **System** is expensive because a lot of **technology** goes into making it.
- In case of a large strength of students, purchasing tags for everyone is costly.
- Replacing microchip, radio transceiver, antenna and battery in the **system** tiresome and costs money

### III. PROPOSEDSYSTEM:

WI -FI Modem is used for tracking and identification purpose. In our project, the principle aim is to discuss the viability of Touch free smart gadget technology. Our Touch free smart gadget consist of WI-FI module for tracking, fingerprint sensor for identification, MEMS sensor to recognize abnormal moment like EPILEPSY, vibration sensor as a reminder and an emergency switch to give alter signal. The principle aim of our project is to propose a viable technological solution

for a single multipurpose touch free smart gadget to avoid malfunction or fraud in large companies. Everyone has patterns of friction ridges on their fingers, and it is this pattern that is called fingerprint. Fingerprints are uniquely detailed, durable over an individual's lifetime, and difficult to alter.

- It is an active mode and it covers large area
- It is compact and portable gadget
- Inbuilt Wi-Fi and Bluetooth
- Consumes less power
- LAN to share employee data through wi-fi
- Electronic control Technology

Wi-fi module for tracking and identification purpose. In our project, the principle aim is to discuss the viability of Touch free smart gadget technology. Our Touch free smart gadget consist of WI-FI module for tracking, fingerprint sensor for identification, MEMS sensor to recognize abnormal moment like EPILEPSY, vibration sensor as a reminder and an emergency switch to give alter signal. The principle aim of our project is to propose a viable technological solution for a single multipurpose touch free smart gadget to avoid malfunction or fraud in large companies. Everyone has patterns of friction ridges on their fingers, and it is this pattern that is called fingerprint. Fingerprints are uniquely detailed, durable over an individual's lifetime, and difficult to alter.

- It is an active mode and it covers large area
- It is compact and portable gadget
- Inbuilt Wi-Fi and Bluetooth
- Consumes less power
- LAN to share employee data through wi-fi
- Electronic control Technology
- Does not require pairing with modem

#### IV. BLOCK DIAGRAM OF PROPOSED SYSTEM

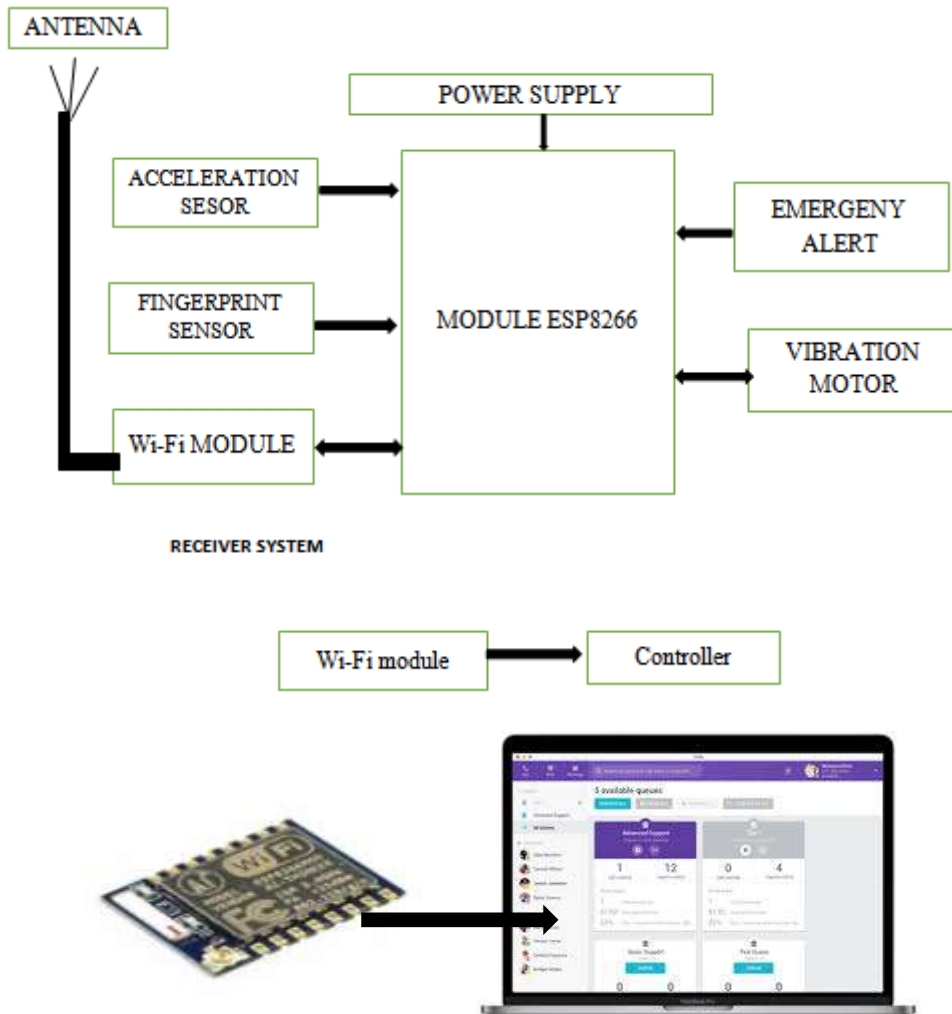

#### HARDWARE:

- Node MCU ESP8266
- Fingerprint sensor
- MEMs accelerator sensor
- Push button switch(for emergency purpose)
- Vibration motor
- Li-Fe battery

#### SOFTWARE

- AURDINO IDE



## DESIGN AND CONSTRUCTION:

### FIRST SWITCH:

- This switch is used for first time enrolment of employees fingerprint into gadget.

### SECOND SWITCH:

- This switch is used for verification of employees fingerprint and put attendance. They have to press their finger every time while they are entering into the company campus.

### THIRD SWITCH:

- This switch is used send emergency alert signal to the controller while an employee.

### FINGERPRINT SCANNER:

- Every day while entering into the company, employee should leave their impression on fingerprint thumb scanner to enable the gadget and give presence.

## V. RESULT AND DISSCUTION:

- TRACKING
- EMERGENCY
- VERIFICATION

### ADVANTAGES:

- Flexibility and portable.
- It is and also handy
- It is used to share data without internet
- It consume less time
- Open source IOT Platform
- Easily programmable
- Low cost & Simple to Implement
- WI-FI and Bluetooth enabled

### APPLICATIONS:

- Healthcare.
- Employee identification & For tracking purpose □ Industries & companies.
- Schools & colleges.
- Military purpose
- Sending emergency alert To/From employee
- Simple UART & USB communication port

### FUTURE SCOPE:

- Controlling of automobile □ Home door lock system
- Can voting from home
- To provide RFID based biometric solutions that set industry standards while bringing the touch less, convenient and high security benefits to all business verticals.

## VI. CONCLUSION:

In this proposed system, smart attendance and tracking system is done by using Wi-Fi module and fingerprint sensor. The transformation of information can be delivered without a hitch. This system is used for tracing of employee in company/industry. A touch free attendance monitoring system is mandatory in pandemic situation like COVID-19. Most of the existing systems are time consuming and biometric fingerprint system. This approach aims to solve the issues.

## REFERENE

- [1]. <http://www.electronicshub.org/password-based-door-lock-system-using-8051-microcontroller/>
- [2]. [http://en.wikipedia.org/wiki/Electronic\\_lock](http://en.wikipedia.org/wiki/Electronic_lock)
- [3]. Longe O.O. (2009), || Implementation of Student Attendance System Using RFID Technology||, B. Tech project Report, Ladoke Akintola University of Technology, Ogbomoso, Nigeria.
- [4]. <http://www.alphacard.com/id-cards/biometric-uses>
- [5]. Mohd Firdaus Bin Mahyidin (2008). Students' attendance system using RFID technology. Malaysia. [8]. Mohamed A.B, Abdel-Hamid A and Mohammed K.Y.,(2009), "Implementation of an improved secure
- [6]. Dawes A.T. (2004), || Is RFID for Your Library||, Journal of Access Services, Volume 2(4), pp 7-13.
- [7]. <http://www.lenvica.com/attendance-software/?gclid=CjwKCAiA4Y7YBRB8Eiw>



- ADV1haV5bfDRI2wWWBNyh582PpUGV  
8rAYeRHIDe\_owhiAqt\_X\_7Yv-  
gEfsBoCGbQQAvD\_BwE
- [8]. Amin A. Al-Zarouni, Nassar H.Fakhro—  
Mobile RFID Tracking System|| Computer  
Engineering Department American  
University of Sharjah, UAE.