

# Electrical Vehicle Battery Charging Using Multiple Sources

Manasi Patil<sup>#</sup>, Vipul Khalati<sup>#</sup>, Vishwajeet Patil<sup>#</sup>, Sudarshan Patil<sup>#</sup>  
P.Balakrishnan\*

<sup>#</sup> Student, Electrical Engineering, Annasaheb Dange College of Engineering and Technology Ashta, Maharashtra, India

\*Professor, Electrical Engineering, Annasaheb Dange College of Engineering and Technology Ashta, Maharashtra, India

Date of Submission: 28-03-2023

Date of Acceptance: 07-04-2023

**ABSTRACT**— Batteries are the primary sources of power in electrical vehicles. In electrical vehicles we use battery are not more sufficient after few miles of charging and not efficient performances. So here is purpose of new battery management system. This study the presents an all-inclusive review of the proportional entire and gladden solution for electrical vehicles in battery difficulties also in depth examination on it. In this new battery management system, we use two batteries. One is main battery and other is auxiliary battery. One battery for charging and other battery for discharging. For the charging the battery we use solar panel as renewable energy sources. While other hand discharging the battery. When one battery is charging, the other battery is simultaneously discharging this paper aims mainly focus on pollution free as well as its capacity is solving the disposition problems of the electric vehicle.

**Keywords**—electrical vehicle battery management system, battery, pulse width modulation

## I. INTRODUCTION

An electric vehicle is vehicle having with one and more electric or traction motors. The EVs can be charged by non-renewable sources otherwise self-contained battery or solar panel & fuel cell, but this is an expensive option. The system is not useful only for electric vehicles, but also for electric aircraft and electric spacecraft, road & rail vehicles, surface and underwater vessel. Today the modern is world demanding cutting-edge tech that can solve current as well as future problems. Looking specifically at India's problems, we can see that the main problem is the lack of fossil fuels. As you know, fuel prices (Diesel and Gasoline) are increasing as soon as days passing.

Fossil fuels cause a great deal of pollution around the world. Therefore, need to move to EVs that are using renewable energy sources than that of traditional ones. Using renewable & energy sources such as the Solar panel Energy is be generated electrical energy for that further using. To overcome and control the pollution which happens by vehicles and transportations system. There is utilization of clean and renewable energy sources which will provide electrical energy to electrical vehicles. There is another a problem of electrical energy storage in the electrical vehicle which are less efficient, low capacity and in the load side problems faces there are time requirement for charge electrical vehicle, discharge of vehicle on the way or in journey. To run continuous and save time the implementation of renewable energy system in vehicle for charge battery continuously. The technology for solar photovoltaic battery charge controllers has advanced dramatically over the past five years. The most exciting new technology, PWM charging, has become very popular. Pulse Width Modulation (PWM) is the most effective means to achieve constant voltage battery charging by switching the solar system controller's power devices. When in PWM regulation, the current from the solar array tapers according to the battery's condition and recharging needs. In order to reduce the consumption of fossil fuel energy in transportation and make the environment clean and green, we have developed an electric vehicle that uses solar energy and electricity to drive. Solar cells are used to harness the sun's energy to generate voltage and charge batteries. EVs that can be charged by batteries will hit the market. Battery electric vehicles (BEVs) rely primarily on battery technology. It achieved comfort and ease of use not found in gasoline vehicles at the time. In EVs, BMS's monitor and

the control battery charge & discharges, making operation more economical. The BMS increases aging without harming the battery while maintaining battery safety and reliability. Various monitoring techniques are used to maintain battery health, such as voltage, current, and ambient temperature. This has to do with the SOC, health & related services of life, as well as the max capacity of the battery. EVs play a nonsense but important role as they make so much zero emit no harmful and use charges wisely. EVs are equip with a large number of the cells that require the effective BMS while supplying the required energy. Batteries in electric vehicles must provide long-lasting energy, high performance. Commonly traction batteries used to be seen are lead acid, Li quality ion, and lithium used metal hydride batteries. Of that these of the good traction batteries, lithium ion is the most commonly used due to has advantages and performance.

**1. Need:** The automotive industry has become one of the popular industries in the world, on an economic level as well as in terms of research and development. To upgrade safety of customer and pedestrians exposed more and more technical material in the vehicles. In addition, there are additional cars on the roads, making it practicable to move instantly and comfortably. However, this has developed in a dramatic increase in air pollution such as PM, nitrogen oxides (NOx), CO and sulphur dioxide (SO<sub>2</sub>) in urban environments. Carbon dioxide (CO<sub>2</sub>) of total 28% emissions and cargo deport has 70% of the convey section discharge by European union report. The high technologist countries has power to encourage electrical vehicles used to keep away from concentrations of pollution of air, CO<sub>2</sub>, other greenhouse gases. Electric vehicles has the following advantages behind conventional vehicles: zero emission, simplicity, reliability, cost, comfort, efficiency, accessibility, range, charging time, battery cost, mass and weight.

## II. BLOCK DIAGRAM

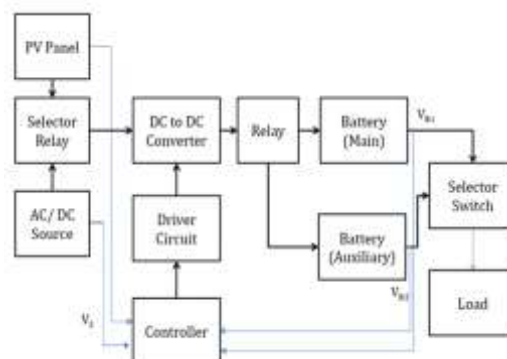

FIG 1: Block Diagram of EV battery charging

Experimental setup for solar and AC/DC power sources of Electric vehicle battery charging systems. Two batteries were used in this new battery management system. First battery is main battery and the second is auxiliary battery. Using multiple power sources, such as solar or AC/DC power. The output of both the sources is connected to the selector relay. Both the sources of output voltage are checked by controller with the help of voltage sensor and then controller give the signal to relay, select the source one both of them. Then output of power source is connected to DC-DC converter. Buck converter is used because solar panel has maximum voltage is 18-20V but we want 12-14V voltage for charging the battery so that buck converter converts the 18-20V voltage into 12-14V voltage. Then DC-DC converter through that power given for charging the battery. Both the battery percentage are checked by controller then signal give the relay to charge the battery as per condition. And other battery is connected to load side. Driver circuit is used to isolation between controller and DC-DC converter.

### A. Selection of components:

- **PV Panel:**  
For charging of 12V, 8AH battery, the solar panel is selected on basis of following calculations.  
Voltage = 12V  
Current = 4A  
Power rating  $> V \times I > 48W$ .  
Therefore, a 50W solar panel is selected.

- **AC / DC Source:**  
The primary role of AC/DC power adapter is to convert alternating current (AC) into a regulated direct current (DC) voltage.

- **Relay:**  
A 5V relay is selected for the interface.
- **Battery (Load) Specifications:**  

Battery Type	Lead Acid
Voltage	12V
Capacity	Main Battery: 8.5AH
- **Controller:**  
The controller selection is done on basis of following requirements:
  - Analog to digital converter input voltage sensing.
  - Serial communication interface for debugging.
  - Digital input/output ports for switch and LED interface.
  - PWM pins for duty cycle control.

- **DC to DC Converter**  
For selection of MOSFET, the load power, voltage and current ratings are considered. The maximum working voltage is 20V and maximum charging current for the battery is 4A. The MOSFET selected should have voltage rating at least three times the load voltage rating hence MOSFET voltage rating should be greater than 60V. The current rating of selected MOSFET should be greater than two times the rated load current hence MOSFET current should be greater than 8A.

Therefore, MOSFET 2N6849/51 is selected with following specifications  
 Voltage = 200V  
 Current = 20A

- **Opto Coupler:**  
The desired isolation and coupling between low voltage microcontroller and high voltage MOSFET is provided through PC817 based opto coupler driver circuit.
- **Switches:**  
A Toggle Switch is an electromechanical switch which uses a lever or baton as an actuator.
- **LED:**  
LEDs can be considered as a simple digital output device. The LED is used as indicator to display the status of operation in digital form.

- **Voltage Sensors:**  
For voltage sensing, a voltage divider arrangement is used.

The maximum possible input voltage is considered to be 20V. The Arduino is board can withstand maximum of 5V voltage level. Hence voltage divider components should be designed to get output voltage of 5V maximum. The output voltage of voltage divider is,

Assuming value of  $R_2 = 1K\Omega$ , the value of resistance  $R_1$  can be calculated as,

### III. RESULT

#### A.Simulation Result:

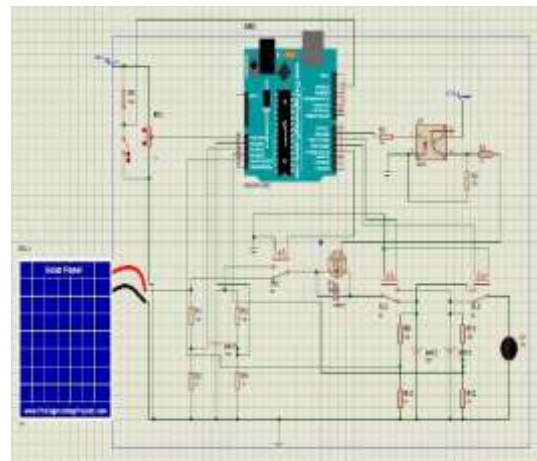

FIG 2: Simulation model of proteus

In this proteus simulation, according to new battery management system we combine two batteries. In this proteus simulation we tested its current and voltage.

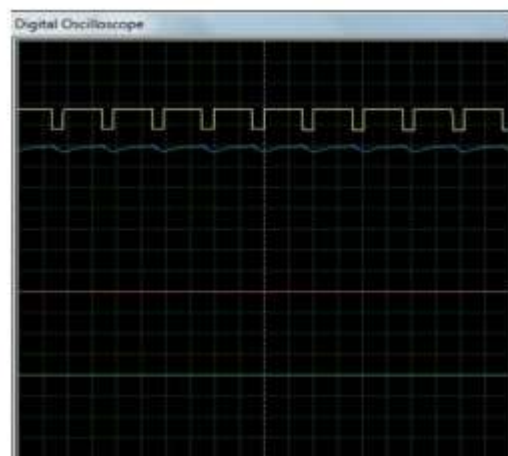

FIG 3: Battery charging on electricity board

Solar panel voltage is not sufficient to charge the battery then automatically they shift on electricity board which charge the battery. First waveform is voltage waveform and second waveform is current waveform.

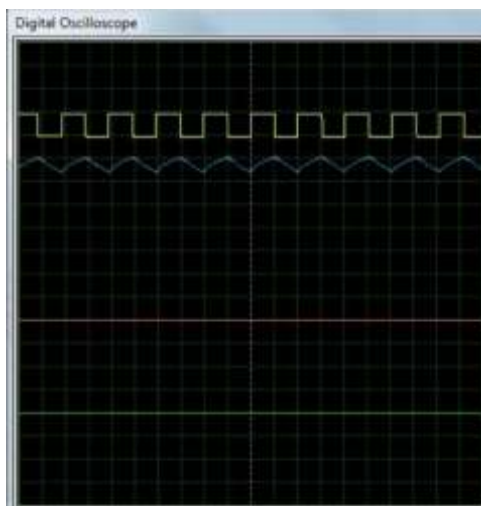

FIG 4: Battery charging on solar panel

Solar panel voltage is sufficient to charge the battery because its voltage is greater than reference voltage. First waveform is voltage waveform and second waveform is current waveform.

#### B. Hardware Result:



FIG 5: Hardware of EV battery charging by multiple sources



FIG 6: Output of hardware

#### IV. CONCLUSION

Now days normal vehicles are converts into electrical vehicles because electrical vehicles are free from pollution and compared to other types of vehicles, electrical vehicles are low running cost. We enhance the efficiency of the battery by using new battery management system. In the new battery management system, we used 2 battery and form a new battery for vehicles. The new battery management can consequentially enhance the performance of the electrical vehicles. In the electrical vehicles important component is battery management that encourages warranty safety, battery operation is reliable and efficiency. The outcomes are maximum efficiency charging, fast alternate charging, and a completely capacity of healthy battery.

#### REFERENCES

- [1]. "The New Battery Management System in Electric Vehicle", International Journal of Engineering Research & Technology (IJERT), Vol.10, Issue 07 July 2021
- [2]. "Smart Self Charging Batteries in Electric Vehicle", International Research Journal of Engineering and Technology (IRJET), Vol.06, Issue 03 Mar 2019, Page no.546
- [3]. "Solar and Wind Powered Electric Vehicle", International Journal for Modern Trends in Science and Technology, Issue Feb 2022, Page no.187
- [4]. "Generation of Electrical Power by a wind Turbine for charging Moving Electric Cars", Journal of Energy Technologies and Policy, Vol.4, Issue Jan 2014
- [5]. "A microcontroller based active solar water heating system for domestic applications", International Journal of renewable energy Research, Vol.3, Issue 14 oct 2013

- [6]. “Hybrid Electric Vehicles Energy Management Strategies”, springer: Simona Onori, Lorenzo Serrao, Giorgio Rizzoni.
- [7]. <https://www.smev.in/ev-industry>
- [8]. [https://en.wikipedia.org/wiki/Lithium-ion\\_battery](https://en.wikipedia.org/wiki/Lithium-ion_battery)
- [9]. <https://www.tesla.com/blog/bit-about-batteries>