

# Optimization of vertical milling process ANOVA and ANN technique parameters of EN24 by using

Reshma Shabbir Shabbir, Prof. S. S. Survase

Date of Submission: 15-10-2022

Date of Acceptance: 31-10-2022

## I. INTRODUCTION

### 1.1 Machining

Machining is any of various processes in which a piece of raw material is cut into a desired final shape and size by a controlled material-removal process. The processes that have this common theme, controlled material removal, are today collectively known as subtractive manufacturing, in distinction from processes of controlled material addition, which are known as additive manufacturing. Exactly what the "controlled" part of the definition implies can vary, but it almost always implies the use of machine tools (in addition to just power tools and hand tools).

Machining is a part of the manufacture of many metal products, but it can also be used on materials such as wood, plastic, ceramic, and composites. A person who specializes in machining is called a machinist. A room, building, or company where machining is done is called a machine shop. Machining can be a business, a hobby, or both. Much of modern-day machining is carried out by computer numerical control (CNC), in which computers are used to control the movement and operation of the mills, lathes, and other cutting machines.

### 1.2 Overview of machining technology

Machining is any process in which a cutting tool is used to remove small chips of material from the work piece (the work piece is often called the "work"). To perform the operation, relative motion is required between the tool and the work. This relative motion is achieved in most machining operation by means of a primary motion, called "cutting speed" and a secondary motion called "feed". The shape of the tool and its penetration into the work surface, combined with these motions, produce the desired shape of the resulting work surface.

### Machining operations

There are many kinds of machining operations, each of which is capable of generating a certain part geometry and surface texture.

In **turning**, a cutting tool with a single cutting edge is used to remove material from a rotating workpiece to generate a cylindrical shape. The primary motion is provided by rotating the work piece, and the feed motion is achieved by moving the cutting tool slowly in a direction parallel to the axis of rotation of the work piece.

**Drilling** is used to create a round hole. It is accomplished by a rotating tool that typically has two or four helical cutting edges. The tool is fed in a direction parallel to its axis of rotation into the work piece to form the round hole.

In **boring**, a tool with a single bent pointed tip is advanced into a roughly made hole in a spinning work piece to slightly enlarge the hole and improve its accuracy. It is a fine finishing operation used in the final stages of product manufacture.

**Reaming** is one of the sizing operations that removes a small amount of metal from a hole that already drilled.

In **milling**, a rotating tool with multiple cutting edges is moved slowly relative to the material to generate a plane or straight surface. The direction of the feed motion is perpendicular to the tool's axis of rotation. The speed motion is provided by the rotating milling cutter. The two basic forms of milling are:

- Peripheral milling
- Face milling.

Other conventional machining operations include shaping, planing, broaching and sawing. Also, grinding and similar abrasive operations are often included within the category of machining.

### 1.3 Milling

Milling may refer to:

- Milling (grinding), the process of grinding grain or other materials in a mill
- Milling (machining), the process of machining metal via non-abrasive rotary cutting
- removing asphalt pavement with a milling machine
- Photochemical milling (disambiguation)
- the act of using the trigonometry of an angular mil to determine size and distance for rifle and short distance artillery calculations
- a part of the leather crusting process
- a type of boxing session used in training by the British Army

Milling also refers to the process of breaking down, separating, sizing, or classifying aggregate material. For instance rock crushing or grinding to produce uniform aggregate size for construction purposes, or separation of rock, soil or aggregate material for the purposes of structural fill or land reclamation activities. Aggregate milling processes are also used to remove or separate contamination or moisture from aggregate or soil and to produce "dry fills" prior to transport or structural filling.

#### 1.3.1 Milling (machining)

Milling is the machining process of using rotary cutters to remove material from a workpiece by advancing (or feeding) in a direction at an angle with the axis of the tool. It covers a wide variety of different operations and machines, on scales from small individual parts to large, heavy-duty gang milling operations. It is one of the most commonly used processes in industry and machine shops today for machining parts to precise sizes and shapes.

Milling can be done with a wide range of machine tools. The original class of machine tools for milling was the milling machine (often called a mill). After the advent of computer numerical control (CNC), milling machines evolved into machining centers (milling machines with automatic tool changers, tool magazines or carousels, CNC control, coolant systems, and enclosures), generally classified as vertical machining centers (VMCs) and horizontal machining centers (HMCs). The integration of

milling into turning environments and of turning into milling environments, begun with live tooling for lathes and the occasional use of mills for turning operations, led to a new class of machine tools, multitasking machines (MTMs), which are purpose-built to provide for a default machining strategy of using any combination of milling and turning within the same work envelope.

#### Process

Milling is a cutting process that uses a milling cutter to remove material from the surface of a workpiece. The milling cutter is a rotary cutting tool, often with multiple cutting points. As opposed to drilling, where the tool is advanced along its rotation axis, the cutter in milling is usually moved perpendicular to its axis so that cutting occurs on the circumference of the cutter. As the milling cutter enters the workpiece, the cutting edges (flutes or teeth) of the tool repeatedly cut into and exit from the material, shaving off chips (swarf) from the workpiece with each pass. The cutting action is shear deformation; material is pushed off the workpiece in tiny clumps that hang together to a greater or lesser extent (depending on the material) to form chips. This makes metal cutting somewhat different (in its mechanics) from slicing softer materials with a blade.

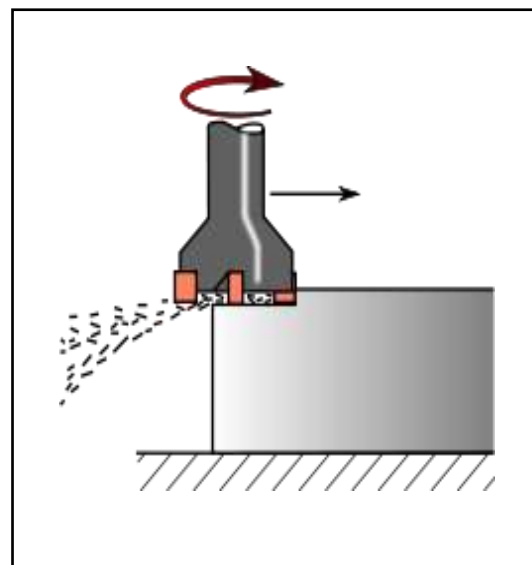

Fig.1.1:- Face milling process (cutter rotation axis is vertical)

The milling process removes material by performing many separate, small cuts. This is accomplished by using a cutter with many teeth, spinning the cutter at high speed, or advancing the

material through the cutter slowly; most often it is some combination of these three approaches. The speeds and feeds used are varied to suit a combination of variables. The speed at which the piece advances through the cutter is called feedrate, or just feed; it is most often measured in length of material per full revolution of the cutter.

There are two major classes of milling process:

- In **face milling**, the cutting action occurs primarily at the end corners of the milling cutter. Face milling is used to cut flat surfaces (faces) into the workpiece, or to cut flat-bottomed cavities.
- In **peripheral milling**, the cutting action occurs primarily along the circumference of the cutter, so that the cross section of the milled surface ends up receiving the shape of the cutter. In this case the blades of the cutter can be seen as scooping out material from the work piece. Peripheral milling is well suited to the cutting of deep slots, threads, and gear teeth.

Milling cutter

**Milling cutters** are cutting tools typically used in milling machines or machining centres to perform milling operations (and occasionally in other machine tools). They remove material by their movement within the machine (e.g., a ball nose mill) or directly from the cutter's shape (e.g., a form tool such as a hobbing cutter).

#### 1.4 Types of Milling Cutter

##### End mill



Fig.1.2:- Slot, end mill, and ballnose cutters

End mills (middle row in image) are those tools which have cutting teeth at one end, as well as on the sides. The words end mill are generally used to refer to flat bottomed cutters, but also include

rounded cutters (referred to as ball nosed) and radiused cutters (referred to as bull nose, or torus). They are usually made from high speed steel or cemented carbide, and have one or more flutes. They are the most common tool used in a vertical mill.

##### Roughing end mill

Roughing end mills quickly remove large amounts of material. This kind of end mill utilizes a wavy tooth form cut on the periphery. These wavy teeth form many successive cutting edges producing many small chips, resulting in a relatively rough surface finish. During cutting, multiple teeth are in contact with the workpiece reducing chatter and vibration. Rapid stock removal with heavy milling cuts is sometimes called hogging. Roughing end mills are also sometimes known as "rippa" cutters.

##### Ball nose cutter

All nose cutters or ball end mills (lower row in image) are similar to slot drills, but the end of the cutters are hemispherical. They are ideal for machining 3-dimensional contoured shapes in machining centers, for example in moulds and dies. They are sometimes called ball mills in shop-floor slang, despite the fact that that term also has another meaning. They are also used to add a radius between perpendicular faces to reduce stress concentrations.

There is also a term bull nose cutter, which refers to a cutter having a corner radius that is fairly large, although less than the spherical radius (half the cutter diameter) of a ball mill; for example, a 20-mm diameter cutter with a 2-mm radius corner. This usage is analogous to the term bull nose center referring to lathe centers with truncated cones; in both cases, the silhouette is essentially a rectangle with its corners truncated (by either a chamfer or radius Don).

##### Slab mill

Slab mills are used either by themselves or in gang milling operations on manual horizontal or universal milling machines to machine large broad surfaces quickly. They have been superseded by the use of cemented carbide-tipped face mills which are then used in vertical mills or machining centres.



Fig.1.3:- High speed steel slab mill

**Side-and-face cutter**

The side-and-face cutter is designed with cutting teeth on its side as well as its circumference. They are made in varying diameters and widths depending on the application. The teeth on the side allow the cutter to make unbalanced cuts (cutting on one side only) without deflecting the cutter as would happen with a slitting saw or slot cutter (no side teeth).

Cutters of this form factor were the earliest milling cutters developed. From the 1810s to at least the 1880s they were the most common form of milling cutter, whereas today that distinction probably goes to end mills.



Fig.1.4:- Side and face cutter

**Involute gear cutter**

There are 8 cutters (excluding the rare half sizes) that will cut gears from 12 teeth through to a rack (infinite diameter).



Fig.1.5:- Involute gear cutter

**Hob**

These cutters are a type of form tool and are used in hobbing machines to generate gears. A cross section of the cutter's tooth will generate the required shape on the workpiece, once set to the appropriate conditions (blank size). A hobbing machine is a specialised milling machine.



Fig.1.6:- Hobbing cutter

**Thread mill**

Whereas a hob engages the work much as a mating gear would (and cuts the blank progressively until it reaches final shape), a thread



milling cutter operates much like an endmill, traveling around the work in a helical interpolation.



Fig.1.7:- A solid multiple-form thread milling cutter.

**Face mill**

A face mill is a cutter designed for facing as opposed to e.g., creating a pocket (end mills). The cutting edges of face mills are always located along its sides. As such it must always cut in a horizontal direction at a given depth coming from outside the stock. Multiple teeth distribute the chip load, and since the teeth are normally disposable carbide inserts, this combination allows for very large and efficient face milling.

**1.5 Mounting the Workpiece for Face Milling:**

When face milling, the workpiece may be clamped to the table or angle plate or supported in a vise, fixture, or jig.

Large surfaces are generally face milled on a vertical milling machine with the workpiece clamped directly to the milling machine table to simplify handling and clamping operations.

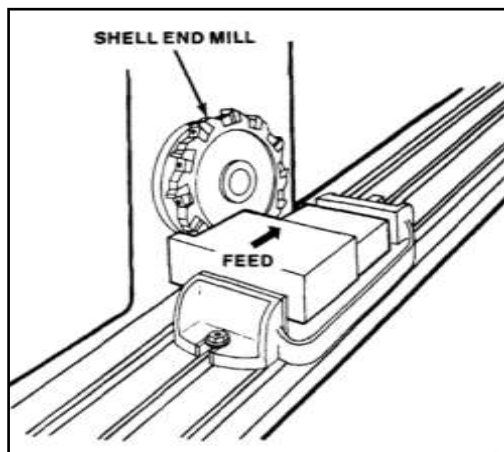

Fig1.8:-Face milling.

Angular surfaces can also be face milled on a swivel cutter head milling machine (Figure). In this case, the workpiece is mounted parallel to the table and the cutter head is swiveled to bring the end milling cutter perpendicular to the surface to be produced.

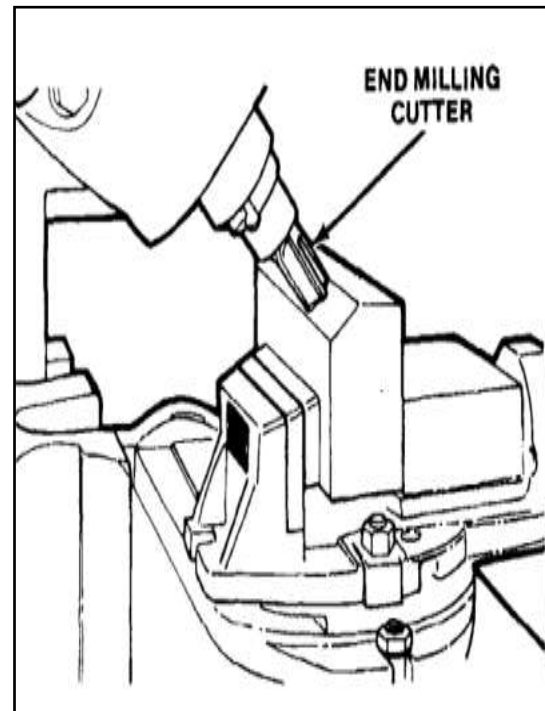

Fig1.9:- Angular face milling.

During face milling operations, the workpiece should be fed against the milling cutter so that the pressure of the cut is downward, thereby holding the piece against the table. Whenever possible, the edge of the workpiece should be in line with the center of the cutter. This position of the workpiece in relation to the cutter will help eliminate slippage.

**1.6 Various Process Parameters in milling operation:**

**Overview:**

The four key mechanical inputs in metal removal operations are feed, speed, depth of cut, and cooling. Manipulating the feed, speed and depth of cut can maximize the benefits of a particular cutting fluid and can increase productivity. However, like most decisions, the choice of feed, speed and depth of cut must be based on the customer's objectives. What is their goal in this application? Do they want to manufacture parts faster or maximize tool life? How important is the surface finish and dimensional accuracy of the part? Answers to these

questions will drive their decisions on feeds, speeds and depth of cut.

**1) Speed:**

Speed is the rate of rotation of the spindle where the tool is held. It is measured in revolutions per minute (RPMs).

**2) Feed:**

Feed is the rate at which the tool is moved into the part or the part into the tool. Feed is measured in feet, inches or millimeters per time period.

**3) Depth of Cut (DOC):**

When setting the depth of cut, the workpiece should be brought up to just touch the revolving cutter. After a cut has been made from this setting, measurement of the workpiece is taken. At this point, the graduated dial on the traverse feed is locked and used as a guide in determining the depth of cut. When starting the cut, the workpiece should be moved so that the cutter is nearly in contact with its edge, after which the automatic feed may be engaged. When a cut is started by hand, care must be taken to avoid pushing the corner of the workpiece between the teeth of the cutter too quickly, as this may result in cutter tooth breakage. In order to avoid wasting time during the operation, the feed trips should be adjusted to stop the table travel just as the cutter clears the workpiece.

**4) Cooling:**

Cooling medium used in lathe machine affects on roundness i.e. surface smoothness of material along with speed, feed, and depth of cut. The turning with cooling was showed that roundness value was lower than dry-cutting. It means that the turning with cooling was the better process for quality of mild steel. Moreover, increasing cutting speed in dry cutting would be increasing roundness quality of workpieces. On the other hand, on cooling cutting with high cutting speed was not increasing roundness quality of mild steel. Furthermore, increasing feed rate in cooling turning would be decreasing roundness quality but in dry-cutting was not different.

### 1.7 SURFACE ROUGHNESS

With the more precise demands of modern engineering products, the control of surface texture together with dimensional accuracy has become more important. It has been investigated that the surface texture greatly influences the functioning of the machined parts. The properties such as appearance, corrosion resistance, wear resistance,

fatigue resistance, lubrication, initial tolerance, ability to hold pressure, load carrying capacity, noise reduction in case of gears are influenced by the surface texture. Whatever may be the manufacturing process used, it is not possible to produce perfectly smooth surface. The imperfections and irregularities are bound to occur. The manufactured surface always departs from the absolute perfection to some extent. The irregularities on the surface are in the form of succession of hills and valleys varying in height and spacing. These irregularities are usually termed as surface roughness, surface finish, surface texture or surface quality. These irregularities are responsible to a great extent for the appearance of a surface of a component and its suitability for an intended application.

#### 1.7.1 Factors Affecting Surface Roughness

- Vibrations
- Material of the work piece
- Type of machining
- Rigidity of the system consisting of machine tool, fixture cutting tool and work
- Type, form, material and sharpness of cutting tool
- Cutting conditions i.e., feed, speed and depth of cut
- Type of coolant used

#### 1.7.2 Reasons for Controlling surface finish

- To improve the service life of the components
- To improve the fatigue resistance
- To reduce initial wear of parts
- To have a close dimensional tolerance on the parts
- To reduce frictional wear
- To reduce corrosion by minimizing depth of irregularities
- For good appearance
- If the surface is not smooth enough, a turning shaft may act like a reamer and the piston rod like a broach. However, as already explained perfectly smooth surface is not always required, the requirement of surface texture depends upon the specific application of the part.

#### 1.7.3. The stylus probe instruments currently in use for surface finish measurement

##### (a) Profilometer:

Profilometer is an indicating and recording instrument used to measure roughness in microns. The principle of the instrument is similar to gramophone pick up. It consists of two principal units: a tracer and an amplifier. Tracer is a finely

pointed stylus. It is mounted in the pickup unit which consists of an induction coil located in the field of a permanent magnet. When the tracer is moved across the surface to be tested, it is displaced vertically up and down due to the surface irregularities. This causes the induction coil to move in the field of the permanent magnet and induces a voltage. The induced voltage is amplified and recorded. This instrument is best suited for measuring surface finish of deep bores

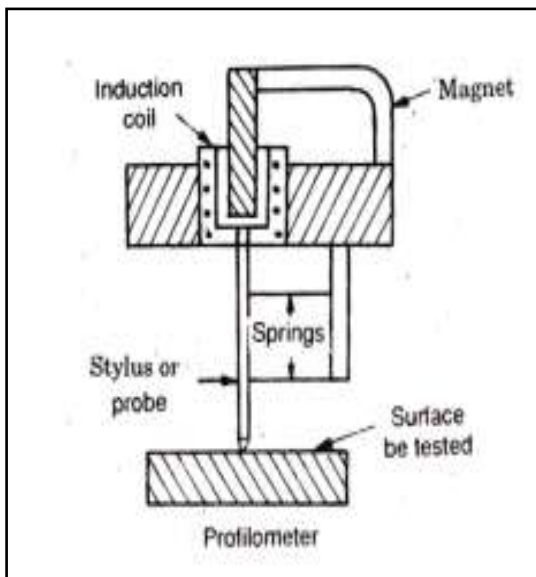

Fig.1.10:- Profilometer diagram

**(b) The Tomlinson surface meter**

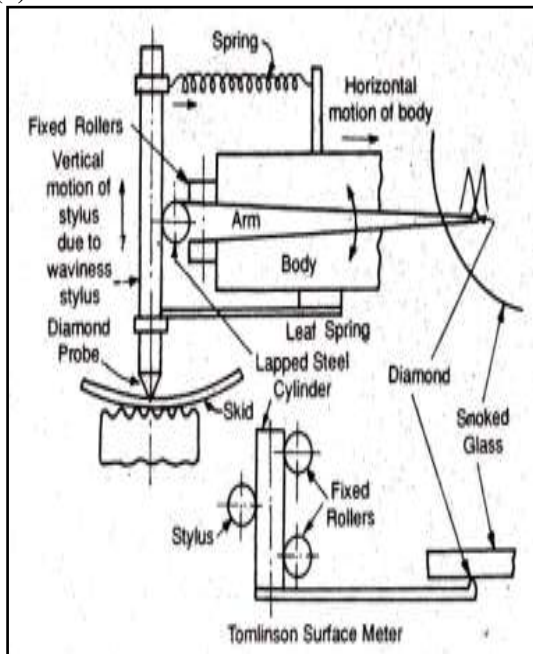

Fig.1.11:- Tomlinson Surface meter working

The Tomlinson surface meter is a comparatively cheap and reliable instrument. It was originally designed by Dr. Tomlinson.

It consists of a diamond probe (stylus) held by spring pressure against the surface of a lapped steel cylinder and is attached to the body of the instrument by a leaf spring. The lapped cylinder is supported on one side by the probe and on the other side by fixed rollers. A light spring steel arm is attached to the lapped cylinder. It carries at its tip a diamond scriber which rests against a smoked glass. The motions of the stylus in all the directions except the vertical one are prevented by the forces exerted by the two springs. For measuring surface finish the body of the instrument is moved across the surface by screw rotated by asynchronous motor. The vertical movement of the probe caused by surface irregularities makes the horizontal lapped cylinder to roll. This causes the movement of the arm attached to the lapped cylinder. A magnified vertical movement of the diamond scriber on smoked glass is obtained by the movement of the arm. This vertical movement of the scriber together with horizontal movement produces a trace on the smoked glass plate. This trace is further magnified at X 50 or X 100 by an optical projector for examination.

**(c) The Taylor Hobson Talysurf:**

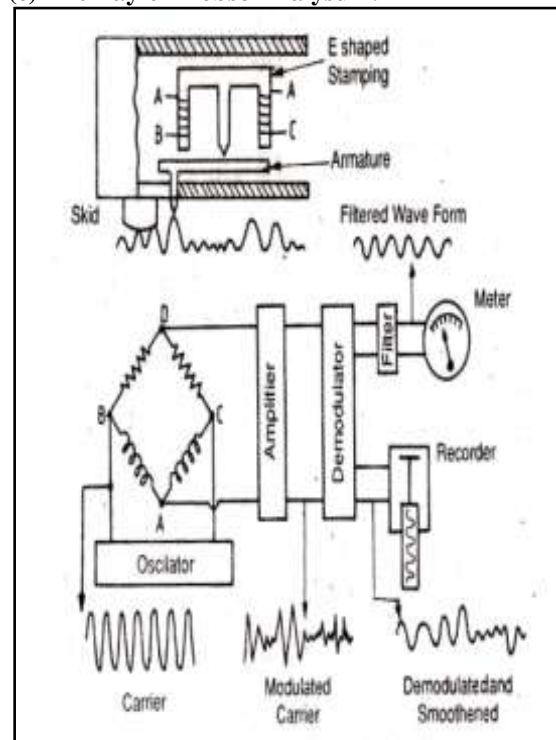

Fig.1.12:- Taylor Hobson Talysurf working

Taylor-Hobson Talysurf is a stylus and skid type of instrument working on carrier modulating principle. Its response is more rapid and accurate as compared to Temlinson Surface Meter. The measuring head of this instrument consists of a sharply pointed diamond stylus of about 0.002 mm tip radius and skid or shoe which is drawn across the surface by means of a motorized driving unit. In this instrument the stylus is made to trace the profile of the surface irregularities, and the oscillatory movement of the stylus is converted into changes in electric current by the arrangement as shown in Fig. The arm carrying the stylus forms an armature which pivots about the centre piece of E-shaped stamping. On two legs of (outer pole pieces) the E-shaped stamping there are coils carrying an a.c. current. These two coils with other two resistances form an oscillator. As the armature is pivoted about the central leg, any movement of the stylus causes the air gap to vary and thus the amplitude of the original a.c. current flowing in the coils is modulated. The output of the bridge thus consists of modulation only as shown in Fig. This is further demodulated so that the current now is directly proportional to the vertical displacement of the stylus only.

#### (d) Profilograph

The principle of Working of a tracer type profilograph is shown in Fig. The work to be tested is placed on the table of the instrument. The work and the table are traversed with the help of a lead screw.

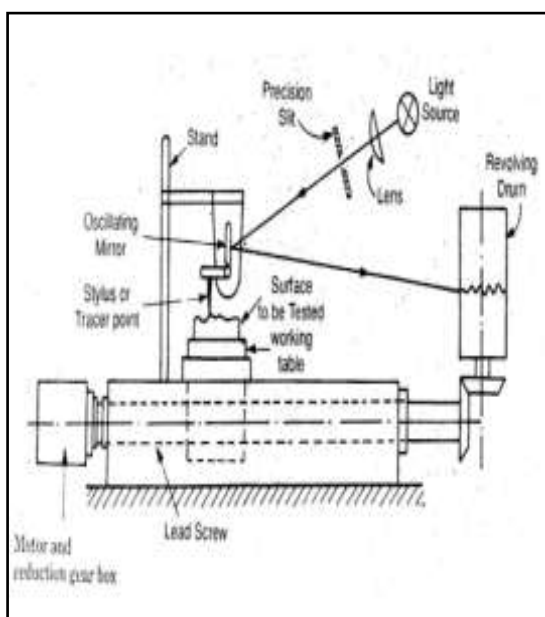

Fig.1.13:- Profilograph working

The stylus which is pivoted to a mirror moves over the tested surface. Oscillations of the tracer point are transmitted to the mirror. A light source sends a beam of light through lens and a precision slit to the oscillating mirror. The reflected beam is directed to a revolving drum, upon which a sensitized film is arranged. This drum is rotated through two bevel gears from the same lead screw that moves the table of the instrument. A profilogram will be obtained from the sensitized film, that may be sub-sequent analyzed to determine the value of the surface roughness

#### 1.8 Analysis of variance (ANOVA)

**Analysis of variance (ANOVA)** is a collection of statistical models used to analyze the differences among group means and their associated procedures (such as "variation" among and between groups), developed by statistician and evolutionary biologist Ronald Fisher. In the ANOVA setting, the observed variance in a particular variable is partitioned into components attributable to different sources of variation. In its simplest form, ANOVA provides a statistical test of whether or not the means of several groups are equal, and therefore generalizes the t-test to more than two groups. ANOVAs are useful for comparing (testing) three or more means (groups or variables) for statistical significance. It is conceptually similar to multiple two-sample t-tests, but is more conservative (results in less type I error) and is therefore suited to a wide range of practical problems.

##### 1.8.1 Background and terminology

ANOVA is a particular form of statistical hypothesis testing heavily used in the analysis of experimental data. A test result (calculated from the null hypothesis and the sample) is called statistically significant if it is deemed unlikely to have occurred by chance, assuming the truth of the null hypothesis. A statistically significant result, when a probability (p-value) is less than a threshold (significance level), justifies the rejection of the null hypothesis, but only if the prior probability of the null hypothesis is not high.

In the typical application of ANOVA, the null hypothesis is that all groups are simply random samples of the same population. For example, when studying the effect of different treatments on similar samples of patients, the null hypothesis would be that all treatments have the same effect (perhaps none). Rejecting the null hypothesis would imply that different treatments result in altered effects.



By construction, hypothesis testing limits the rate of Type I errors (false positives) to a significance level. Experimenters also wish to limit Type II errors (false negatives). The rate of Type II errors depends largely on sample size (the rate will increase for small numbers of samples), significance level (when the standard of proof is high, the chances of overlooking a discovery are also high) and effect size (a smaller effect size is more prone to Type II error).

The terminology of ANOVA is largely from the statistical design of experiments. The experimenter adjusts factors and measures responses in an attempt to determine an effect. Factors are assigned to experimental units by a combination of randomization and blocking to ensure the validity of the results. Blinding keeps the weighing impartial. Responses show a variability that is partially the result of the effect and is partially random error.

ANOVA is the synthesis of several ideas and it is used for multiple purposes. As a consequence, it is difficult to define concisely or precisely.

"Classical ANOVA for balanced data does three things at once:

1. As exploratory data analysis, an ANOVA is an organization of an additive data decomposition, and its sums of squares indicate the variance of each component of the decomposition (or, equivalently, each set of terms of a linear model).
2. Comparisons of mean squares, along with an F-test ... allow testing of a nested sequence of models.
3. Closely related to the ANOVA is a linear model fit with coefficient estimates and standard errors."

In short, ANOVA is a statistical tool used in several ways to develop and confirm an explanation for the observed data.

Additionally:

4. It is computationally elegant and relatively robust against violations of its assumptions.
5. ANOVA provides industrial strength (multiple sample comparison) statistical analysis.
6. It has been adapted to the analysis of a variety of experimental designs.

As a result: ANOVA "has long enjoyed the status of being the **most used** (some would say abused) statistical technique in psychological research." ANOVA "is probably the **most useful** technique in the field of statistical inference."

ANOVA is difficult to teach, particularly for complex experiments, with split-plot designs being notorious. In some cases the proper application of the method is best determined by problem pattern recognition followed by the consultation of a classic authoritative test.

### 1.8.2 Design-of-experiments terms

- **Balanced design**

An experimental design where all cells (i.e. treatment combinations) have the same number of observations.

- **Blocking**

A schedule for conducting treatment combinations in an experimental study such that any effects on the experimental results due to a known change in raw materials, operators, machines, etc., become concentrated in the levels of the blocking variable. The reason for blocking is to isolate a systematic effect and prevent it from obscuring the main effects. Blocking is achieved by restricting randomization.

- **Design**

A set of experimental runs which allows the fit of a particular model and the estimate of effects.

- **DOE**

Design of experiments. An approach to problem solving involving collection of data that will support valid, defensible, and supportable conclusions.

- **Effect**

How changing the settings of a factor changes the response. The effect of a single factor is also called a main effect.

- **Error**

Unexplained variation in a collection of observations. DOE's typically require understanding of both random error and lack of fit error.

- **Experimental unit**

The entity to which a specific treatment combination is applied.

- **Factors**

Process inputs an investigator manipulates to cause a change in the output.

- **Lack-of-fit error**

Error that occurs when the analysis omits one or more important terms or factors from the process model. Including replication in a DOE allows separation of experimental error into its components: lack of fit and random (pure) error.

- **Model**

Mathematical relationship which relates changes in a given response to changes in one or more factors.

- **Random error**

Error that occurs due to natural variation in the process. Random error is typically assumed to be normally distributed with zero mean and a constant variance. Random error is also called experimental error.

- **Randomization**

A schedule for allocating treatment material and for conducting treatment combinations in a DOE such that the conditions in one run neither depend on the conditions of the previous run nor predict the conditions in the subsequent runs.

- **Replication**

Performing the same treatment combination more than once. Including replication allows an estimate of the random error independent of any lack of fit error.

- **Responses**

The output(s) of a process. Sometimes called dependent variable(s).

- **Treatment**

A treatment is a specific combination of factor levels whose effect is to be compared with other treatments.

### 1.8.3 Problem Statement

Metal cutting processes are commonly used processes with an objective of altering the shape of the component with desired surface finish and tolerances. Vertical milling machine has applications in many automobile and other industrial applications. Though motorized control and automation has taken over the industry since long time very few studies has been performed on setting the correct parameters for the machining of the EN 24 steel using vertical milling process. Variable range of speed, feed and depth of cut are available with the vertical milling machines. It is important to set the process parameters in such a

way that optimum operating is done with good surface finish and fair material removal rate.

### 1.8.4 Objectives And Scope Of Project

1. To find out surface finish and material removal rate of EN24 material.
2. To compare the data from different experimental analysis and perform ANOVA analysis on the data collected, select the best possible combinations made by tation or combinations of the process parameters which are suitable for the process.
3. To study and confirm the observations made by the actual testing by using ANN & Fuzzy Logic optimization technique and plot thegraph to give the final conclusion.

### 1.8.5 Scope of proposed work

1. Selection of the process parameters and selecting the combinations to study.
2. Perform machining on the workpieces selected using different parametric combinations selected from Taguchi matrix.
3. To Perform ANOVA and select optimum process parameter or parameters and surface finish, Material Removal Rate values for the same.

### 1.8.6 Methodology of Proposed Work

1. To select the suitable application for the vertical milling machining process for the purpose of study by doing background research: Mild steel is one of the most common materials used for machine part building. There are different requirements of the surface finish and hardness of the mild steel as per application. It is usual practice to manufacture the product using simple machinery and then performing quality checks for the required hardness and surface finish value.
2. To select the machining parameters and their variable values to be studied which will be dependent up on range of parameter variation offered by the selected material process: We will study the relation between different machining parameters on the surface roughness and hardness of the plain milling work piece of mild steel. Feed, speed, and depth of cut these parameters have a direct effect on productivity, tool life, and machine requirements. Therefore, these parameters will be chosen for study.
3. To perform parametric design of experiments for the testing of milling machining processes:

Combinations experimentation are selected according to Taguchi matrix.

4. To use ANOVA technique to select the best combination from the alternative Taguchi matrix combinations of the process.
5. To study surface finish and Material removal rate for the best suited application selected from the ANOVA technique.
6. Conclude with the selection of optimum parametric combination of the process parameters of vertical milling process:

Optimum combination of machining parameters for vertical milling process will be selected so as to achieve good surface finish and less machining time.

## II. 2. LITERATURE SURVEY

**Mohammed T. Hayajneh**[1] presented a paper on “**A Study of the Effects of Machining Parameters on the Surface Roughness in the End-Milling Process**”. In this paper, a series of experiments has been conducted in order to begin to characterize the factors affecting surface roughness for the end-milling process. The effect of spindle speed, feed rate, depth of cut on surface roughness of aluminum samples was studied. The model generated, which includes the effect of spindle speed, feed rate, depth of cut, and the any two-variable interactions, predicts surface roughness reasonably well. The deviation between predicted and measured surface roughness values was within an error band of about 12%. The machining parameters investigated influenced the surface finish of the machined workpiece significantly. In general, the study shows that cutting feed is by far the most dominant factor of those studied. The most important interactions, that effect surface roughness of machined surfaces, were between the cutting feed and depth of cut, and between cutting feed and spindle speed.

**AbhishekDubey** [2] presented a paper on “**A Parametric Design Study of End Milling Operation using Grey Based Taguchi Method**”. This paper presents the multiple response optimization of end milling parameter using grey based taguchi method. Experiments were designed and conducted based on L27 orthogonal array design .The milling parameter were spindle speed, depth of cut, feed rate and pressurized coolant jet and the response was surface roughness. EN31, high carbon alloy steel which achieves a high degree of hardness and compressive strength and abrasion resistance. The present work is focused to

study the effect of process parameter such as speed, feed rate, and depth of cut, pressurized coolant jet on surface roughness in end milling of EN31 steel. Surface roughness values were recorded for each experiment. The feed rate was identified as the most influential process parameter on surface roughness. The results obtained by Grey relational method were compared with that of the optimal condition obtained.

**Rajesh Kumar** presented [3] “**Modeling and optimization of end milling parameters on aluminum 6061 alloy using GRA based Taguchi method coupled with PCA**” in this methodThe optimization of end milling parameters with multiple performance characteristics (high MRR, low Ra) for the machining of Al6061 was carried out. The optimum conditions for obtaining higher grey relational grade such as C1S2F3D2, (Coolant emp. on, speed 765Rpm, feed 50mm/min, Depth of cut 0.8mm) were obtained. ANOVA study has been carried out to obtain the significant factors for MRR, Ra and GRG. It is found that feed and depth of cut are the most influential factor for MRR. Further, Coolant Employment, feed and depth of cut are significant factors for Ra and Coolant Employment, feed is most affecting parameters for GRG. After conducting the confirmation test with the optimal level of end milling process parameters, it has been found that GRA based Taguchi method coupled with PCA is best suitable for solving the quality problem of machining in the end milling of Al-6061 alloy.

**Wasim Khan** worked on [4] “**Optimization of End Milling Process Parameters for Minimization of Surface Roughness of AISI P20 Steel**” The optimal sets of process parameters were obtained for performance measures using Taguchi design of experiment methodology. From the analysis of variances, the most significant factor was concluded spindle speed and also from main effects plot of process parameters to the output response factor as a surface roughness. The spindle speed also shows the minimum values of S/N ratio -13.6608 in S/N ratio graph regarding to process parameters. The ranks obtained in Analysis of variance as follows, 1st rank to spindle speed, 2nd rank to feed rate and 3rd rank to depth of cut in both analysis (response Table for Means and : Response Table for Signal to Noise Ratios: Smaller is better). The confirmation test is taken and comparison made between the predicted value of surface roughness which is obtained from regression analysis equation and the actual value of

surface roughness which is obtained from practical experiment process.

**P. R. Periyanan**[5] presented work on “A study on the machining parameters optimization of micro-end milling process” this paper focuses the Taguchi technique for the optimization in micro-end milling operation to achieve maximum metal removal rate (MRR) considering the spindle speed, feed rate and depth of cut as the cutting parameters. An orthogonal array, signal-to-noise (S/N) ratio and Pareto analysis of variance (ANOVA) are employed to analyze the effect of these milling parameters. The analysis of the result shows that the optimal combination for higher metal removal rate (MRR) is medium cutting speed, high feed rate and high depth of cut. Using Taguchi method for design of experiment (DOE), other significant effects such as the interaction among milling parameters are also investigated. The study shows that the Taguchi method is suitable to solve the stated problem. Based on the verification experiment it is concluded that the percentage of error of response was less.

**R. Ramanujam**[6] presented study on “**Multi-Response Optimization Using ANOVA and Desirability Function Analysis: A Case Study in End Milling of Inconel Alloy**” The present study investigated the parameter optimization of end milling operation for Inconel 718 super alloy with multi-response criteria based on the Taguchi method and desirability function analysis. Experimental tests were carried out based on an L9 orthogonal array of Taguchi method. The influence of machining factors cutting speed, feed rate and depth of cut were analysed on the performances of surface roughness and material removal rate. The optimum cutting conditions are obtained by Taguchi method and desirability function. The analysis of variance (ANOVA) is also applied to investigate the effect of influential parameters. A regression model was developed for surface roughness and material removal rate as a function of cutting velocity, feed rate and depth of cut. Finally, the confirmation experiment was conducted for the optimal machining parameters, and the betterment has been proved.

**A. R. Lande**[7] presented topic called “**Gray Relational Based Analysis of Al-6351**” In the

present study, experiments are conducted on aluminium 6351 materials to see the effect of process parameter variation in this respect. An attempt has also been made to obtain Optimum cutting conditions with respect to roughness parameters and Material removal rate. In order to carry out the multi objective optimization Gray relational analysis is used which gives gray relational grade and from the analysis it can be concluded that feed is the most significant parameter for the combined objective function while, speed is the least significant parameter.

**Harshraj D. Wathore**[8] presented paper called “**Investigation of Optimum Cutting Parameters for End Milling of H13 Die Steel using Taguchi based Grey Relational Analysis**” This paper presents the study of the parameter optimization of end milling operation for H13 die steel with multi-response criteria based on the Taguchi L9 orthogonal array with the grey relational analysis. Surface roughness and material removal rate are optimized with consideration of performance characteristics namely cutting speed, feed rate and depth of cut. A grey relational grade obtained from the grey relational analysis is used to solve the end milling process with the multiple performance characteristics. Additionally, the analysis of variance (ANOVA) is to be applied to identify the most significant factor. Finally, confirmation tests are performed to make a comparison between the experimental results and developed model.

**Bhargav Patel** [9] worked on “**Parametric Optimization of Temperature during CNC End Milling of Mild Steel Using RSM**” In the present work, response surface methodology has been used for design of experiments during CNC end milling of mild steel material. Temperature measurement during end milling process is carried out using Cr-Al thermocouple to study the effect of various process parameters on temperature during machining. Optimization of process parameters such as cutting speed, feed and depth of cut has been carried out by ANOVA analysis using MINITAB 14.0 software. The results show the importance of parameters to optimize the temperature requirement. Conclusions made from contour plots and response surface diagrams are critically discussed.



## 2.1 LITERATURE REVIEW SUMMARY

Reference No.	Research paper/Book/Journal Title	Researcher name	Date of Publication	Conclusion
01	“A Study of the Effects of Machining Parameters on the Surface Roughness in the End-Milling Process”	Mohammed T. Hayajneh.	September 2007	The deviation between predicted and measured surface roughness values was Within an error band of about 12%. The machining Parameters investigated influenced the surface finish of themachined workpiece significantly.
02	“A Parametric Design Study of End Milling Operation using Grey Based Taguchi Method”	AbhishekDubey.	April 2014	The order of importance for the controllable factors to the minimum surface roughness, in sequence, is the feed rate, depth of cut, spindle speed and pressurized Coolant jet.The spindle speed is the most influential control factor among the four end milling process parameters investigated in the present work, when minimization of surface roughness is considered.
03	“Modeling and optimization of end milling parameters on aluminum 6061 alloy using GRA based Taguchi method coupled with PCA”	Rajesh Kumar.	December 2014	The optimum conditions for obtaining higher grey relational grade such as C1S2F3D2, (Coolant emp. on, speed 765Rpm, feed 50mm/min, Depth of cut0.8mm) were obtained.
04	“Optimization of End Milling Process Parameters for Minimization of Surface Roughness of AISI P20 Steel”	Wasim Khan.	April 2016	From the analysis of variances, the most significant factor was concluded spindle speed and also frommain effects plot of process parameters to the output response factor as a

				surface roughness.
05	“A study on the machining parameters optimization of micro-end milling process”	P. R. Periyanan	2011	It is concluded that the Taguchi’s robust design of experiment technique is suitable to analyze the micro end milling problems. From this experimental work shows the optimal parameters for micro-end milling process using Taguchi approach and Pareto ANOVA for data analysis draw same conclusion.
06	“Multi-Response Optimization Using ANOVA and Desirability Function Analysis: A Case Study in End Milling of Inconel Alloy”	R. Ramanujam	April 2014	It has been established that desirability function analysis embedded in Taguchi analysis is an effective optimization tool for optimizing multi-response optimization problems.
07	“Gray Relational Based Analysis of Al-6351”	A. R. Lande.	December 2015	The significant parameters are Feed>Diameter>DOC>Speed. Gray Relational analysis method is successfully applied which gives the gray relational grade.
08	“Investigation of Optimum Cutting Parameters for End Milling of H13 Die Steel using Taguchi based Grey Relational Analysis”	Harshraj D. Wathore.	July 2015	Multi-response problem was successfully converted into single response problem. ANOVA shows that depth of cut is the most significant machining parameter followed by cutting speed, affecting selected response characteristics
09	“Parametric Optimization of Temperature during CNC End Milling of Mild Steel Using RSM”	Bhargav Patel.	January 2014	For particular material different parameters make different relations with response. Depth of cut is the most significant parameter as far as temperature is concerned.

### III. DESIGN OF EXPERIMENT

#### 3.1. MATERIAL USED

Mild steel is one of the most common materials used for machine part building. There are different requirements of the surface finish and hardness of the mild steel as per application. It is usual practice to manufacture the product using simple machinery and then performing quality checks for the required hardness and surface finish value, in case of not meeting the acceptance criteria the work pieces are rejected. In this project work we will study the relation between different machining parameters on the surface roughness and hardness of the plain milling work piece of mild steel using ANOVA technique to avoid lot rejections in the quality check phase.

Low carbon steel, also known as mild steel, contains 0.05 % to 0.26 % of carbon (e.g. AISI 1018, AISI 1020 steel). These steels are ductile and have properties similar to iron. They cannot be modified by heat treatment. They are cheap, but engineering applications are restricted to non-critical components and general paneling and fabrication work. These steels cannot be effectively heat treated. Consequently, there are usually no problems associated with heat affected zones in welding process. The surface properties can be enhanced by carburizing and then heat treating the carbon-rich surface. High ductility characteristic results in poor Machinability.

#### 3.2. Effect of speed, feed and depth of cut on milling

Feed, speed, and depth of cut have a direct effect on productivity, tool life, and machine requirements. Therefore, these elements must be carefully chosen for each operation. Whether the objective is rough milling or finishing will have a great influence on the cutting conditions selected. The phrase speeds and feeds or feeds and speeds refer to two separate velocities in machine tool practice, cutting speed and feed rate. They are often considered as a pair because of their combined effect on the cutting process. Each, however, can also be considered and analyzed in its own right. Cutting speed (also called surface speed or simply speed) is the speed difference (relative velocity) between the cutting tool and the surface of the workpiece it is operating on. It is expressed in units of distance along the workpiece surface per unit of time, typically surface feet per minute (sfm) or meters per minute (m/min). Feed rate (also often styled as a solid compound, feed rate, or called simply feed) is the relative velocity at which the cutter is advanced along the workpiece; its vector is perpendicular to the vector

of cutting speed. Feed rate units depend on the motion of the tool and workpiece; when the workpiece rotates (e.g., in turning and boring), the units are almost always distance per spindle revolution (inches per revolution [in/rev or ipr] or millimeters per revolution [mm/rev]). When the workpiece does not rotate (e.g., in milling), the units are typically distance per time (inches per minute [in/min or ipm] or millimeters per minute [mm/min]), although distance per revolution or per cutter tooth are also sometimes used.

**3.2.1. Cutting speed:** (also called surface speed or simply speed) may be defined as the rate (or speed) at the workpiece surface, irrespective of the machining operation used. A cutting speed for mild steel, of 100 ft/min (or approx 30 meters/min) is the same whether it is the speed of the (stationary) cutter passing over the (moving) workpiece, such as in a turning operation, or the speed of the (rotating) cutter moving past a (stationary) workpiece, such as in a milling operation. What will affect the value of this surface speed for mild steel is the cutting conditions.

Schematically, speed at the workpiece surface can be thought of as the tangential speed at the tool-cutter interface, that is, how fast the material moves past the cutting edge of the tool, although "which surface to focus on" is a topic with several valid answers. In drilling and milling, the outside diameter of the tool is the widely agreed surface. In turning and boring, the surface can be defined on either side of the depth of cut, that is, either the starting surface or the ending surface, with neither definition being "wrong" as long as the people involved understand the difference. An experienced machinist summed this up succinctly as "the workpiece I am milling from" versus "the workpiece I am milling to." He uses the "from", not the "to", and explains why, while acknowledging that some others do not. The logic of focusing on the largest workpiece involved (drill or end mill) is that this is where the highest tangential speed is, with the most heat generation, which is the main driver of tool wear.

For a given material there will be an optimum cutting speed for a certain set of machining conditions, and from this speed the spindle speed (RPM) can be calculated. Factors affecting the calculation of cutting speed are:

- The material being machined (steel, brass, tool steel, plastic, wood)
- The material the cutter is made from (Carbon steel, high speed steel (HSS), carbide, ceramics)

- The economical life of the cutter (the cost to regrind or purchase new, compared to the quantity of parts produced)

Cutting speeds are calculated on the assumption that optimum cutting conditions exist, these include:

- Metal removal rate (finishing cuts that remove a small amount of material may be run at increased speeds)
- Full and constant flow of cutting fluid (adequate cooling and chip flushing)
- Rigidity of the machine and tooling setup (reduction in vibration or chatter)
- Continuity of cut (as compared to an interrupted cut, such as machining square section material in a VMC)
- Condition of material (mill scale, hard spots due to white cast iron forming in castings)

### 3.2.2. Feed Rate:

Feed rate is the velocity at which the cutter is fed, that is, advanced against the workpiece. It is expressed in units of distance per revolution for turning and boring (typically inches per revolution [ipr] or millimeters per revolution). It can be expressed thus for milling also, but it is often expressed in units of distance per time for milling (typically inches per minute [ipm] or millimeters per minute), with considerations of how many teeth (or flutes) the cutter has then determining what that means for each tooth.

Feed rate is dependent on the:

- Type of tool (a small drill or a large drill, high speed or carbide, a boxtool or recess, a thin form tool or wide form tool, a slide knurl or a turret straddle knurl).
- Surface finish desired.
- Power available at the spindle (to prevent stalling of the cutter or workpiece).
- Rigidity of the machine and tooling setup (ability to withstand vibration or chatter).
- Strength of the workpiece (high feed rates will collapse thin wall tubing)
- Characteristics of the material being cut, chip flow depends on material type and feed rate. The ideal chip shape is small and breaks free early, carrying heat away from the tool and work.
- Threads per inch (TPI) for taps, die heads and threading tools.

When deciding what feed rate to use for a certain cutting operation, the calculation is fairly straightforward for single-point cutting tools, because all of the cutting work is done at one point

(done by "one tooth", as it were). With a milling machine or jointer, where multi-tipped/multi-fluted cutting tools are involved, then the desirable feed rate becomes dependent on the number of teeth on the cutter, as well as the desired amount of material per tooth to cut (expressed as chip load). The greater the number of cutting edges, the higher the feed rate permissible: for a cutting edge to work efficiently it must remove sufficient material to cut rather than rub; it also must do its fair share of work.

The ratio of the spindle speed and the feed rate controls how aggressive the cut is, and the nature of the swarf (chip) formed.

### 3.2.3. Depth of Cut:

Cutting speed and feed rate come together with depth of cut to determine the material removal rate, which is the volume of workpiece material (metal, wood, plastic, etc.) that can be removed per unit time. The depth of cut relates to the depth the tool cutting edge engages the work. The depth of cut determines one linear dimension of the area of cut. For example: to reduce the outside diameter (OD) of a workpiece by 0.500 in., the depth of cut would be 0.250 in.

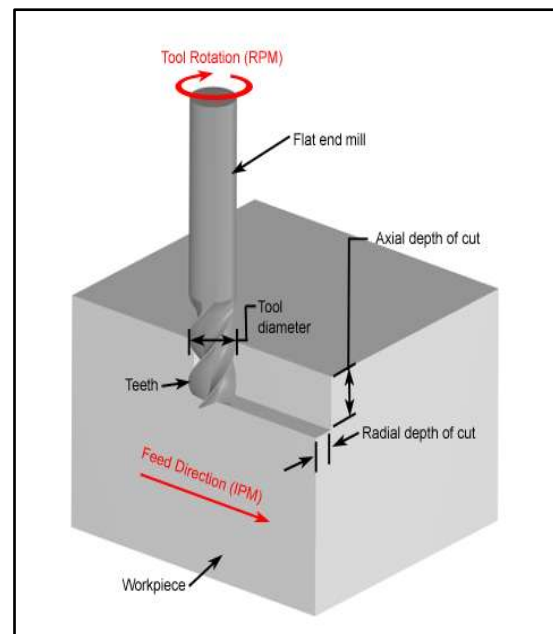

Fig.3.1:-End mill process



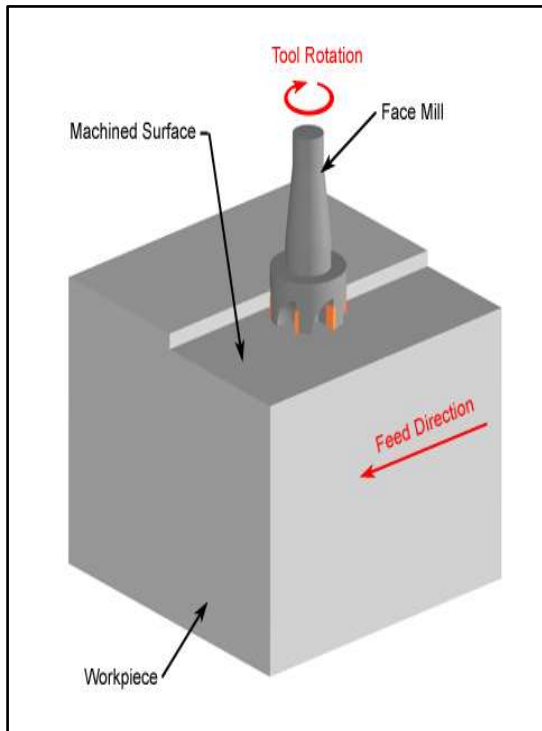

Fig.3.2:-Milling Process2

### 3.3. MACHINING

Machining is one of the most wide spread metal machining process in mechanical manufacturing industry. The goal of changing the geometry of raw material in order to form mechanical parts can be met by putting material together. Conventional machining is one most important material removal methods. Machining is a part of the manufacture all most all metal products. In milling, higher values of cutting parameter offered opportunities for increasing productivity but it also involves greater risk of deterioration in surface quality and tool life. Milling operation is very important material removal process in modern industry.

### 3.4 SURFACE FINISH

Surface finish produced on machined surface plays an important role in production. The surface finish has a vital influence on most important functional properties such as wear resistance, fatigue strength, corrosion resistance and power losses due to friction. Poor surface finish will lead to the rupture of oil films on the peaks of the micro irregularities which lead to a state approaching dry friction and results in decisive wear of rubbing surface. Therefore finishing processes is employed in machining to obtain a very high surface finish.

### 3.5. DESIGN OF EXPERIMENTS

In this process three factors at three levels are chosen which is given in Table 1. The fractional factorial design used is a standard L27 ( $3^3$ ) orthogonal array. This orthogonal array is chosen due to its capability to check the interactions among factors. Each row of the matrix represents one trial. The basic principle in using any design of experiment (DOE) technique is to first identify the key variables in the process and then actively probe those variables to determine their effects on the process output. A typical DOE process consists of three distinct phases, screening, characterization and optimization, although not all three phases are used in every study. Orthogonal designs are particularly useful because the estimate of the effect of a factor is unaffected by which other factors are under consideration. Factorial designs, which involve all possible combinations of levels of all the factors, can be investigated simultaneously. This technique also saves time and money because large number of factors can be investigated simultaneously. One type of complete factorial experiment is  $2^k$  factorial designs; k is the number of factors investigated at two levels. In order to calculate the number of runs, e.g. if  $k=7$  then the number of runs is  $2^7 = 128$  experimental runs. The number of run increases as the k value increases. In order to reduce the number of experimental runs, fractional factorial was introduced which use only a fraction of the total possible combinations of levels. The number of run is given by  $2^{k-1}$ , e.g. if  $k=7$ ,  $2^{(7-1)} = 2^6 = 64$  experimental runs. By using the fractional factorial the number of run has been reduced by half. Taguchi's method adopts the fundamental idea of DOE but simplifies and standardized the factorial and fractional factorial designs so that experiments conducted will produce more consistent results.

#### 3.5.1. Orthogonal Array Experiment

Classical experimental design methods are too complex and are not easy to use. A large number of experiments have to be carried out when the number of process parameters increases. To solve this problem, the Taguchi method uses a special design of orthogonal arrays to study the entire parameter space with only a small number of experiments. According to the Taguchi method, a robust design and an L27 orthogonal array are employed for the experimentation. Three machining parameters are considered as controlling factors – namely, cutting speed, feed rate, depth of cut and each parameter has three levels – namely low, medium and high, denoted by 1, 2 and 3, respectively. Table 1 shows the cutting parameters

and their levels considered for the experimentation. The experimental design considered for the investigation to achieve an optimal surface finish during the milling of Mild steel is based on the L27 orthogonal array shown in Table 2. Based on this, a total number of 27 experiments in machining condition are done; each having a different combination of levels of factors as shown in Table 1 was carried out. Orthogonal arrays are special standard experimental design that requires only a small number of experimental trials to find the main factor effects on output. Before selecting an orthogonal array, the minimum number of experiments to be conducted shall be fixed which is given by:

Table 1:- Process variables and their limits

Parameters	Level 1	Level 2	Level 3
Spindle Speed	300	500	700
Depth of Cut	0.5	1.0	1.5
Feed Rate	100	200	300

Table 2:- Experimental table L27 orthogonal array

Expt. No.	SS RPM	DOC (MM)	FR (MM/MIN)
1	300	0.5	100
2	300	1	100
3	300	1.5	100
4	300	0.5	200
5	300	1	200
6	300	1.5	200
7	300	0.5	300
8	300	1	300

Expt. No.	SS RPM	DOC (MM)	FR (MM/MIN)
9	300	1.5	300
10	500	0.5	100
11	500	1	100
12	500	1.5	100
13	500	0.5	200
14	500	1	200
15	500	1.5	200
16	500	0.5	300
17	500	1	300
18	500	1.5	300
19	700	0.5	100
20	700	1	100
21	700	1.5	100
22	700	0.5	200
23	700	1	200
24	700	1.5	200
25	700	0.5	300
26	700	1	300
27	700	1.5	300



Fig.3.3:- Programme for Machining



Fig.3.4:-CNC machining performed on the Work pieces

Machining operation is performed on the samples chosen of the standard size of 10 cm length and 20 mm diameter. Milling operation with the said input parameters in the table 2 are performed on these samples and 27 turned components are manufactured as a sample pieces to generate the data required performing ANOVA as

well as ANN. MRR can be measured by weighing the component before and after the machining operation performed, and dividing it with the number of minutes taken by the milling operation on that component. Table 2 shows all the measured MRR values for 27 experiments.

### 3.6. SURFACE FINISH MEASUREMENT

Product designers constantly strive to design machinery that can run faster, last longer, and operate more precisely than ever. Modern development of high speed machines has resulted in higher loading and increased speeds of moving parts. Bearings, seals, shafts, machine ways, and gears, for example must be accurate - both dimensionally and geometrically. Unfortunately, most manufacturing processes produce parts with surfaces that are either unsatisfactory from the standpoint of geometrical perfection or quality of surface texture. As industry tries harder to approach perfection, interest has focused more closely than ever before on the micro finishing processes like -- honing, lapping, and super finishing. Each process was designed to generate a particular geometrical surface and to correct specific irregularities and so must be applied carefully to a given production sequence. Also, each process is a final operation in the machining sequence for a precision part and is usually preceded by conventional grinding. This primer begins by explaining how industry controls and measures the precise degree of smoothness and roughness of a finished surface.

In most cases, surface finish control starts in the drafting room. The designer has the responsibility of specifying a surface that will give the maximum performance and surface life at the lowest cost. In selecting a required surface finish for a particular part, the designer must base his/her decision on past experience with similar parts, on field service data, or on engineering tests.

#### 3.6.1 Need of surface finish control

##### 1. To reduce friction

When a film of lubricant must be maintained between two moving parts, the surface irregularities must be small enough so they will not penetrate the oil film under the most severe operating conditions. Bearings, journals, cylinder bores, piston pins, bushings, pad bearings, helical and worm gears, seal surfaces, and machine ways are examples where this condition must be fulfilled.

## 2. To control wear

Surface finish is also important to the wear service of certain parts that are subject to dry friction, such as machine-tools bits, threading dies, stamping dies, rolls, clutch plates, and brake drums. Often, surface finish must be controlled for the purpose of increasing the fatigue strength of highly stressed members which are subjected to load reversals. A smooth surface eliminates the sharp irregularities which are the greatest potential source of fatigue cracks.

For parts such as gears, surface finish control may be necessary to ensure quiet operations. In other cases, however, where a boundary lubrication condition exists or where surfaces may not be compatible, as in two extremely hard surfaces running together, a slightly roughened surface will usually assist in lubrication.

A specific degree of surface roughness is also required in order to accommodate wear-in of certain parts. Most new moving parts do not attain a condition of complete lubrication as a result of imperfect geometry, running clearances, and thermal distortions. Therefore, the surfaces must wear in by a process of actual removal of metal. The surface finish must be a compromise between sufficient roughness for proper wear-in and sufficient smoothness for expected service life.

### 3.7. ROUGHNESS EVALUATION

There are three general methods by which the surface texture and the surface geometry may be explored and evaluated: electronic, optical, and visual or tactual.

#### 1. Electronic

There are two types of electronic instruments which measure actual surface texture: averaging (or velocity type) and profiling (or displacement type). Averaging or tracer-type instruments employ a stylus that is drawn across the surface to be measured. The vertical motion of the tracer is amplified electrically and is impressed on a recorder to draw the profile of the surface or is fed into an averaging meter to give a number (AA) representing the roughness value of the surface. Profiling equipment is used principally in laboratories for research and development applications. Considerable skill is required to operate the equipment and analyze and interpret the data.

#### 2. Optical

Optical or area systems use optical methods for surface evaluation. Equipment ranges from exploration of the surface with simple

microscopes or three-dimensional micro topography to highly sophisticated techniques such as interferometry.

Area systems inspect the entire surface, not simply one line across it. The surface texture in this process is clearly distinguished from the surface geometry. Because there is no stylus, the surface is not mechanically contacted, and thus there can be no damage to the work piece surface. Another important advantage of optical inspection methods is that the biasing effect of the stylus radius is eliminated.

#### 3. Visual to Tactual

The visual or tactual is the simplest and most straight forward method of surface measurement. It is also the least accurate. Figure below shows a commercial set of master precision reference specimens with 15 replicated surfaces, ranging in roughness from 2 to 125 in. in height. Comparators of this type are readily available with various surface finish from 2 to 1000 in. is available. The scales, used with or without a magnifier, are placed adjacent to the work piece under examination and the surfaces are compared visibly or tactually by drawing the tip of the fingernail across each at right angles to the tool marks. The fingernail touch or "feel" will be the same when both finishes are identical.

In this case we have used the electronic measuring instrument and results for the all 27 components are shown in the table below.

Table.3:- Ra value of surface roughness measured from samples

Expt No.	Ra Measured
1	0.518
2	0.646
3	0.917
4	0.538
5	0.737

Expt No.	Ra Measured
9	1.018
10	0.33
11	0.767
12	0.789
13	0.471
14	0.752



15	0.704
16	0.529
17	0.842
18	0.7
19	0.317
20	0.877
21	0.713
22	0.543
23	0.726
24	0.612
25	0.559
26	0.565
27	0.713

$$L_{ij} = \frac{1}{n} \sum_{k=1}^n y_{ijk}^2$$

Where  $L_{ij}$  is the loss function of the  $i^{\text{th}}$  performance characteristic in the  $j^{\text{th}}$  experiment,  $y_{ijk}$  the experimental value of the  $i^{\text{th}}$  performance characteristic in the  $j^{\text{th}}$  experiment at the  $k^{\text{th}}$  trial, and  $n$  the number of trials.

The loss function is further transformed into an S/N ratio. In the Taguchi method, the S/N ratio is used to determine the deviation of the performance characteristic from the desired value. The S/N ratio  $L_{ij}$  for the  $i^{\text{th}}$  performance characteristic in the  $j^{\text{th}}$  experiment can be expressed as

$$n_{ij} = -10 \log_{10}(L_{ij})$$

In contrast, the S/N ratio is a predictor of quality loss that isolates the sensitivity of the products function to noise factors. In robust design one minimizes the sensitivity of noise by seeking combinations of the design parameters setting that maximize the S/N ratio. The evaluation of surface roughness performed using signal to noise ratio analysis is to determine which settings of the controllable factors results in the mean as close as possible to the desired target and a maximum value of the signal- to - noise (S/N) ratio. An analysis of variance (ANOVA) is used to estimate the variance of independent factors.

#### IV. ANALYSIS OF VARIANCE (ANOVA)

##### 4.1. S/N ANALYSIS

The S/N ratio is a concurrent quality metric linked to the loss function (Barker, 1990). By maximizing the S/N ratio, the loss associated can be minimized. The S/N ratio determines the most robust set of operating conditions from variation within the results. The S/N ratio is treated as a response (transform of raw data) of the experiment. In the present investigation, the S/N data analyses have been performed. The effects of the selected turning process parameters on the selected quality characteristics have been investigated through the plots of the main effects based on raw data. The optimum condition for each of the quality characteristics has been established through S/N data analysis aided by the raw data analysis. Taguchi recommends the use of the loss function to measure the performance characteristic deviating from the desired value. The value of the loss function is further transformed into a signal-to-noise (S/N) ratio. The rationale for this switch over to S/N ratios instead of working directly with the quality characteristic measurement is, the S/N ratio is a concurrent statistic –a special kind of data summery. A concurrent statistic is able to look at two or more characteristics of distribution and roll these characteristic into a single number or figure of merit. Usually, there are three categories of performance characteristic in the analysis of the S/N ratio. The loss function for the lower gives better performance characteristic and can be expressed as

##### 4.2 INFLUENCE OF THE CUTTING PARAMETERS ON THE SURFACE ROUGHNESS (RA)

Since each experiment is the combination of different factor levels, it is essential to segregate the individual effect of independent variables. This is done by summing up the performance values for corresponding level setting and then mean is found. Then sum of squares of deviation of each of mean value from grand mean value is calculated. This sum of squares of deviation of a particular variable indicates whether the performance parameter is sensitive to the change of level setting. If the sum of square deviation is close to zero or in significant, one may conclude that design variable is not influencing the performance process ( i.e.) by performing ANOVA, one can conclude which factor is dominating over other and the percentage contribution of that particular independent variable can be found. The S/N ratio for each parameter level is calculated by averaging the S/N ratios obtained when the parameter is maintained at that level.

Table: 4:- The experimental results for surface roughness and its S/N ratio

Sr.No.	SPEED	FEED	DEPTH OF CUT	Ra	calculated S/N ratio(db)
1	300	0.5	100	1.552	3.81783
2	300	1	100	3.83	11.664
3	300	1.5	100	4.905	13.8128
4	300	0.5	200	2.47	7.85394

Sr.No.	SPEED	FEED	DEPTH OF CUT	Ra	calculated S/N ratio(db)
5	300	1	200	3.564	11.0388
6	300	1.5	200	2.795	8.92764
7	300	0.5	300	1.272	2.08974
8	300	1	300	3.07	9.74277
9	300	1.5	300	4.091	12.2366
10	500	0.5	100	1.7	4.60898
11	500	1	100	1.415	3.01513
12	500	1.5	100	3.936	11.9011
13	500	0.5	200	2.216	6.9114
14	500	1	200	2.98	9.48433
15	500	1.5	200	3.783	11.5567
16	500	0.5	300	2.056	6.26046
17	500	1	300	3.276	10.3069
18	500	1.5	300	4.954	13.8991
19	700	0.5	100	2.021	6.11133
20	700	1	100	1.998	6.01191
21	700	1.5	100	1.2	1.58362
22	700	0.5	200	2.397	7.59336
23	700	1	200	2.738	8.74867
24	700	1.5	200	2.946	9.38465
25	700	0.5	300	2.559	8.16141

26	700	1	300	1.803	5.11991
27	700	1.5	300	3.425	10.6932

### 4.3. INTRODUCTION TO ANOVA

The main objective of ANOVA is to extract from the results how much variation each factor causes relative to the total variation observed in the result. Since there are a large number of variables controlling the process, some mathematical models are required to represent the process. However, these models are to be developed using only the significant parameters influencing the process rather than including all the parameters. In order to achieve this, statistical analysis of the experimental results will have to be processed using the analysis of variance ANOVA is a computational technique that enables the estimation of the relative contributions of each of the control factors to the overall measured response. ANOVA can be useful for determining influence of any given input parameter from a series of experimental results by design of experiments for machining process and it can be used to interpret experimental data. Analysis of variance (ANOVA) is a collection of statistical models, and their associated procedures, in which the observed variance in a particular variable is partitioned into components attributable to different sources of variation. In its simplest form, ANOVA provides a statistical test of whether or not the means of several groups are all equal, and therefore generalizes t-test to more than two groups. ANOVA is used in the analysis of comparative experiments, those in which only the difference in outcomes is of interest. The statistical significance of the experiment is determined by a ratio of two variances. This ratio is independent of several possible alterations to the experimental observations: Adding a constant to all observations does not alter significance. Multiplying all observations by a constant does not alter significance. So ANOVA statistical significance results are independent of constant bias and scaling errors as well as the units used in expressing observations.

**Description of ANOVAs:** Analysis of Variance (ANOVA) is a generalized statistical technique used to analyze sample variances to obtain information on comparing multiple population means. This technique is consisted of several fundamental statistical concepts (hypothesis testing, F-test). The confusing part is that we are analyzing

variances to learn about the means (averages). In its simplest form such as One-Factor ANOVA (1FANOVA) or Two Factor (2F-ANOVA), these designs can be considered as a simple Design of Experiments (DOE) as one is examining the effects of one to two factors on a responsible variable. There are several terms/jargons that need to be defined to learn about ANOVA.

**Factor** – A quantitative or a qualitative variable that is expected to exert an impact/effect on a quality characteristic.

**Response Variable (RV)** – The quality characteristic under investigation.

**Sum-of-Squares (SS)** – the sum of squared deviations

**Degrees of Freedom (DOF)** – number of levels -1

For each factor DOF equal to:

For Spindle Speed;  $DOF = 3 - 1 = 2$

For Feed Rate;  $DOF = 3 - 1 = 2$

For Depth of Cut;  $DOF = 3 - 1 = 2$

### 4.4. RESULTS OF ANOVA

In this study twenty seven experiments were conducted at different parameters. For this taguchi L27 orthogonal array was used, which has twenty seven rows and three columns each one has two degrees of freedom. DOF for error is 20 (L27 has 26 DOF six assign to factors and 20 assign to the error). The reason of observing degree of influence of the factor for process parameter in milling three factor each at three level taken into account shown at table 4. Ra and SN ratio for corresponding experiment is given. Results for the ANOVA performed using Minitab are given in the figures shown below. They show the effect of the inputs on the output.

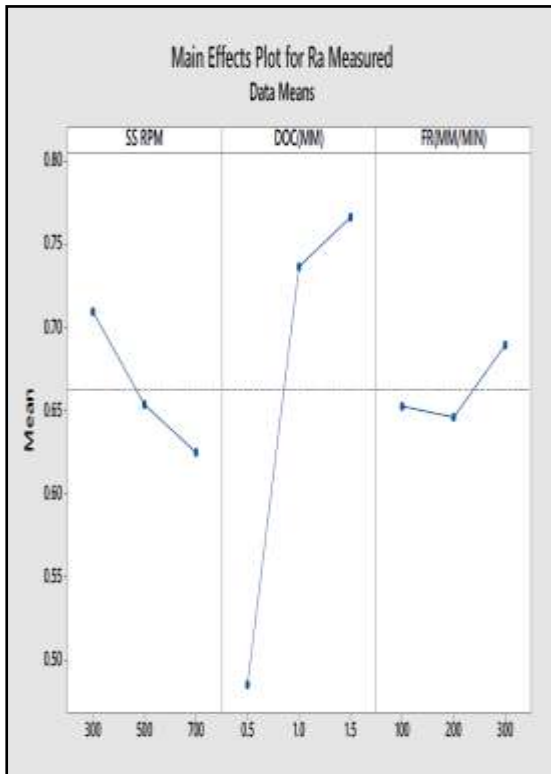

Fig. 4.1:- Main effect plots for work-piece surface roughness Ra ( $\mu\text{m}$ )

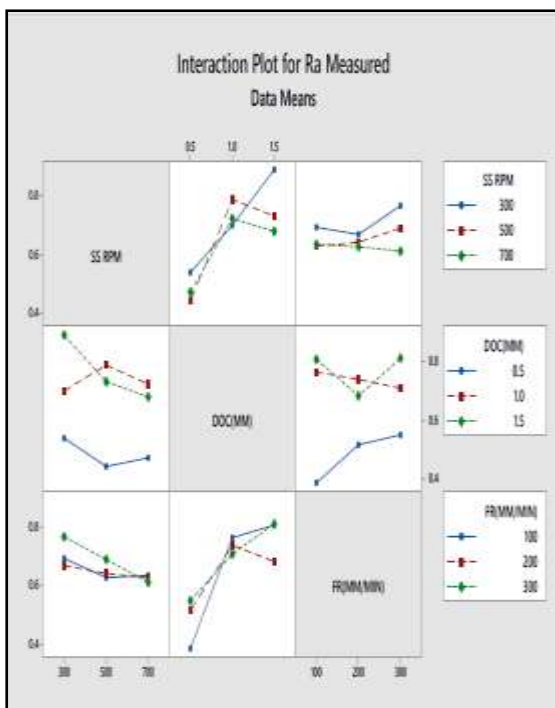

Fig. 4.2:-Interaction plot for Ra measured  
 Figure 4.1 shows the main effect plot for work-piece surface roughness Ra for speed, feed rate and depth of cut. Figure 4.2 shows the Interaction plot for Ra measured.

#### 4.4 ARTIFICIAL NEURAL NETWORKING

##### 4.4.1. Introduction To ANN

It is not possible (at the moment) to make an artificial brain, but it is possible to make simplified artificial neurons and artificial neural networks. These ANNs can be made in many different ways and can try to mimic the brain in many different ways. ANNs are not intelligent, but they are good for recognizing patterns and making simple rules for complex problems. They also have excellent training capabilities which are why they are often used in artificial intelligence research. ANNs are good at generalizing from a set of training data. E.g. this means an ANN given data about a set of animals connected to a fact telling if they are mammals or not, is able to predict whether an animal outside the original set is a mammal from its data. This is a very desirable feature of ANNs, because you do not need to know the characteristics defining a mammal, the ANN will find out by itself.

Artificial Neural Networks, also known as “Artificial neural nets”, “neural nets”, or ANN for short, are a computational tool modeled on the interconnection of the neuron in the nervous systems of the human brain and that of other organisms. Biological Neural Nets (BNN) is the naturally occurring equivalent of the ANN. Both BNN and ANN are network systems constructed from atomic components known as “neurons”. Artificial neural networks are very different from biological networks, although many of the concepts and characteristics of biological systems are faithfully reproduced in the artificial systems. Artificial neural nets are a type of non-linear processing system that is ideally suited for a wide range of tasks, especially tasks where there is no existing algorithm for task completion. ANN can be trained to solve certain problems using a teaching method and sample data. In this way, identically constructed ANN can be used to perform different tasks depending on the training received. With proper training, ANN is capable of generalization, the ability to recognize similarities among different input patterns, especially patterns that have been corrupted by noise.

The term “Neural Net” refers to both the biological and artificial variants, although typically the term is used to refer to artificial systems only. Mathematically, neural nets are nonlinear. Each layer represents a non-linear combination of non-linear functions from the previous layer. Each neuron is a multiple-input, multiple-output (MIMO) system that receives signals from the



inputs, produces a resultant signal, and transmits that signal to all outputs. Practically, neurons in an ANN are arranged into layers. The first layer that interacts with the environment to receive input is known as the input layer. The final layer that interacts with the output to present the processed data is known as the output layer. Layers between the input and the output layer that do not have any interaction with the environment are known as hidden layers. Increasing the complexity of an ANN, and thus its computational capacity, requires the addition of more hidden layers, and more neurons per layer.

Biological neurons are connected in very complicated networks. Some regions of the human brain such as the cerebellum are composed of very regular patterns of neurons. Other regions of the brain, such as the cerebrum have less regular arrangements. A typical biological neural system has millions or billions of cells, each with thousands of interconnections with other neurons. Current artificial systems cannot achieve this level of complexity, and so cannot be used to reproduce the behavior of biological systems exactly

#### 4.4.2. Neuron

In an artificial neural network, neurons can take many forms and are typically referred to as Processing Elements (PE) to differentiate them from the biological equivalents. The PE is connected into a particular network pattern, with different patterns serving different functional purposes. Unlike biological neurons with chemical interconnections, the PE in artificial systems is electrical only, and may be analog, digital, or a hybrid. However, to reproduce the effect of the synapse, the connections between PE are assigned multiplicative weights, which can be calibrated or “trained” to produce the proper system output.

#### 4.4.3. Transfer Function

A single artificial neuron can be implemented in many different ways. The general mathematic definition is as showed in equation

$$y(x) = g \left( \sum_{i=0}^n w_i x_i \right)$$

X is a neuron with n input dendrites and one output axon y(n) and where (w<sub>0</sub>...w<sub>n</sub>) are weights determining how much the inputs should be weighted. g is an activation function that weights how powerful the output (if any) should be from the neuron, based on the sum of the input. If the artificial neuron should mimic a real neuron,

the activation function g should be a simple threshold function returning 0 or 1. This is however, not the way artificial neurons are usually implemented. For many different reasons it is smarter to have a smooth (preferably differentiable) activation function. The output from the activation function is either between 0 and 1, or between -1 and 1, depending on which activation function is used. This is not entirely true, since e.g. the identity function, which is also sometimes used as activation function, does not have these limitations, but most other activation functions use these limitations. The inputs and the weights are not restricted in the same way and can in principle be between -∞ and +∞, but they are very often small values centered on zero. The artificial neuron is also illustrated in figure

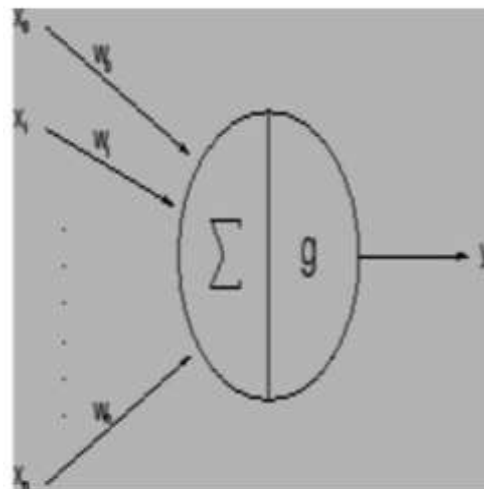

Fig.4.3:- Artificial neuron

#### 4.4.4 Advantages Of ANN

Artificial neural nets have a number of properties that make them an attractive alternative to traditional problem-solving techniques. The two main alternatives to using neural nets are to develop an algorithmic solution, and to use an expert system.

Algorithmic methods arise when there is sufficient information about the data and the underlying theory. By understanding the data and the theoretical relationship between the data, we can directly calculate unknown solutions from the problem space. Ordinary von Neumann computers can be used to calculate these relationships quickly and efficiently from a numerical algorithm.

Expert systems, by contrast, are used in situations where there is insufficient data and theoretical background to create any kind of a reliable problem model. In these cases, the knowledge and rationale of human experts is

codified into an expert system. Expert systems emulate the deduction processes of a human expert, by collecting information and traversing the solution space in a directed manner. Expert systems are typically able to perform very well in the absence of an accurate problem model and complete data. However, where sufficient data or an algorithmic solution is available, expert systems are a less than ideal choice.

Artificial neural nets are useful for situations where there is an abundance of data, but little underlying theory. The data, which typically arises through extensive experimentation may be non-linear, non-stationary, or chaotic, and so may not be easily modeled. Input-output spaces may be so complex that a reasonable traversal with an expert system is not a satisfactory option. Importantly, neural nets do not require any a priori assumptions about the problem space, not even information about statistical distribution. Though such assumptions are not required, it has been found that the addition of such a priori information as the statistical distribution of the input space can help to speed training. Many mathematical problem models tend to assume that data lies in a standard distribution pattern, such as Gaussian or Maxwell-Boltzmann distributions. Neural networks require no such assumption. During training, the neural network performs the necessary analytical work, which would require non-trivial effort on the part of the analyst if other methods were to be used.

#### **4.4.5. Learning**

Learning is a fundamental component to an intelligent system, although a precise definition of learning is hard to produce. In terms of an artificial neural network, learning typically happens during a specific training phase. Once the network has been trained, it enters a production phase where it produces results independently. Training can take on many different forms, using a combination of learning paradigms, learning rules, and learning algorithms. A system which has distinct learning and production phases is known as a static network. Networks which are able to continue learning during production use are known as dynamical systems.

A learning paradigm is supervised, unsupervised or a hybrid of the two, and reflects the method in which training data is presented to the neural network. A method that combines supervised and unsupervised training is known as a hybrid method. A learning rule is a model for the types of methods to be used to train the system, and also a goal for what types of results are to be produced. The learning algorithm is the specific

mathematical method that is used to update the inter-neuronal synaptic weights during each training iteration. Under each learning rule, there are a variety of possible learning algorithms for use. Most algorithms can only be used with a single learning rule. Learning rules and learning algorithms can typically be used with either supervised or unsupervised learning paradigms, however, and each will produce a different effect.

Overtraining is a problem that arises when too many training examples are provided, and the system becomes incapable of useful generalization. This can also occur when there are too many neurons in the network and the capacity for computation exceeds the dimensionality of the input space. During training, care must be taken not to provide too many input examples and different numbers of training examples could produce very different results in the quality and robustness of the network.

#### **4.4.6. Network Parameters**

There are a number of different parameters that must be decided upon when designing a neural network. Among these parameters are the number of layers, the number of neurons per layer, the number of training iterations, et cetera. Some of the more important parameters in terms of training and network capacity are the number of hidden neurons, the learning rate and the momentum parameter.

#### **4.4.7. Neurons In The Hidden Layer**

Hidden neurons are the neurons that are neither in the input layer nor the output layer. These neurons are essentially hidden from view, and their number and organization can typically be treated as a black box to people who are interfacing with the system. Using additional layers of hidden neurons enables greater processing power and system flexibility. This additional flexibility comes at the cost of additional complexity in the training algorithm. Having too many hidden neurons is analogous to a system of equations with more equations than there are free variables: the system is over specified, and is incapable of generalization. Having too few hidden neurons, conversely, can prevent the system from properly fitting the input data, and reduces the robustness of the system.

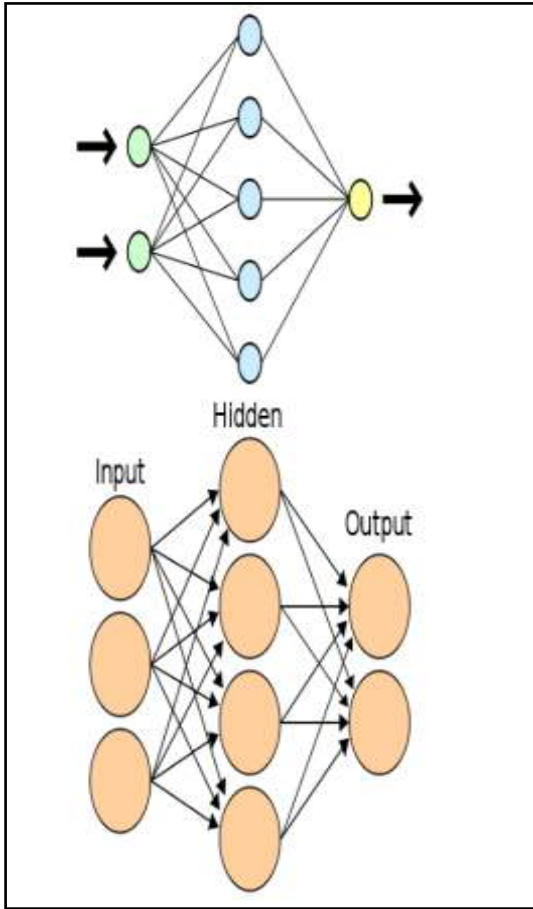

Fig.4.4:- Neurons in the Hidden layer

#### 4.4..8MATLAB Procedure For ANN

Procedure from the MATLAB tool is followed to perform ANN below are the image of the same.



	4	5	6	7	8	9	10	11	12	13	14
1	1000	1000	1000	1000	1000	1000	1250	1250	1250	1250	1250
2	0.1000	0.2000	0.3000	0.1000	0.2000	0.3000	0.1000	0.2000	0.3000	0.1000	0.2000
3	0.1000	0.2000	0.2000	0.3000	0.3000	0.2000	0.1000	0.1000	0.3000	0.3000	0.2000

  

	1	2	3	4	5	6	7	8	9	10	11
1	1.9230	1.8380	4.8650	2.4700	1.5640	2.7850	1.2700	3.0700	4.8910	1.7000	1.4150

Fig.4.5:- Input and target variables created in the MATLAB

Data of inputs and output of Surface finish is inputted to the MATLAB for all the 27 tests ran on the process. Data is been input by transposing it as ANN considers ever row as a parameter by default.

Sample data for inputs of 1 to 15 is also provided in the sample space for which results will be predicted. Set of sample data is shown in the image below.

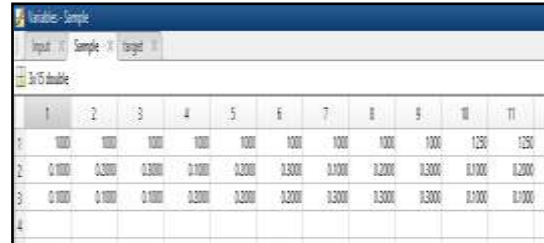

	1	2	3	4	5	6	7	8	9	10	11
1	1000	1000	1000	1000	1000	1000	1000	1000	1000	1250	1250
2	0.1000	0.2000	0.3000	0.1000	0.2000	0.3000	0.1000	0.2000	0.3000	0.1000	0.2000
3	0.1000	0.1000	0.1000	0.2000	0.2000	0.2000	0.3000	0.3000	0.3000	0.3000	0.1000

Fig.4.6:- Sample data set variable

Neural networking tool is started by command after all the variables required for the analysis are defined

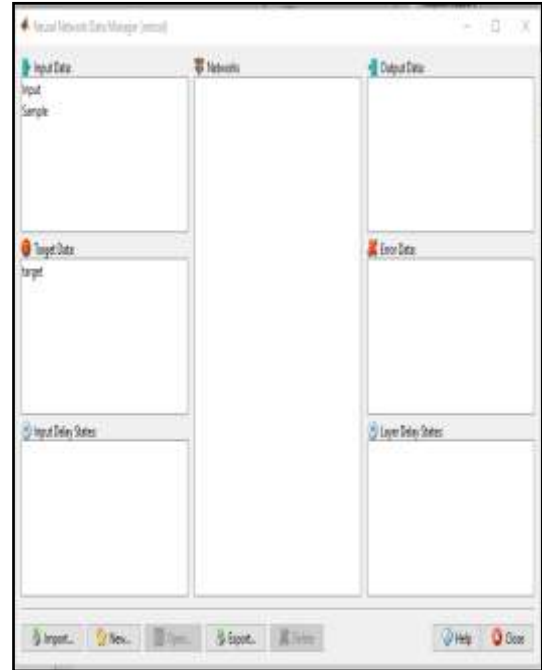

Fig.4.7:-Sorting the defined variables

After starting the neural network command variables input and sample data sets are imported as input sets and target variable is imported as a target for the ANN.

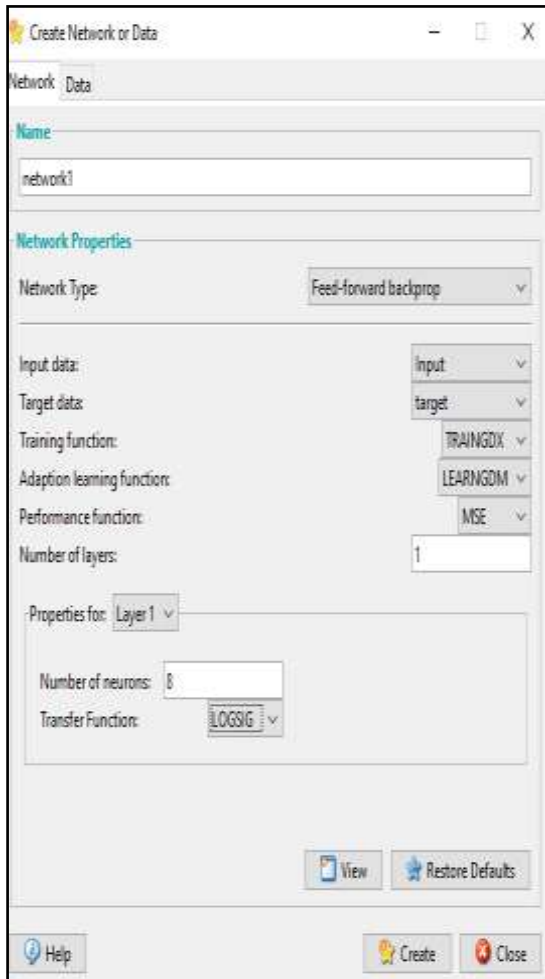

Fig.4.8:-New network creation setting

After that new network is created using input and target data with the settings as shown in the figure 5.5, also hidden layer number of neutrons is selected as 8.

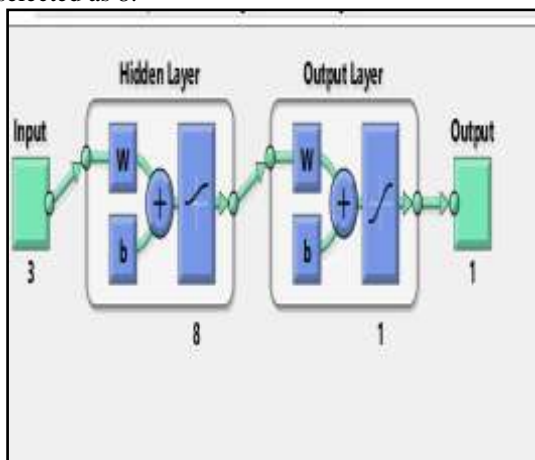

Fig.4.9:- Neural network for the solution of Ra value ANN

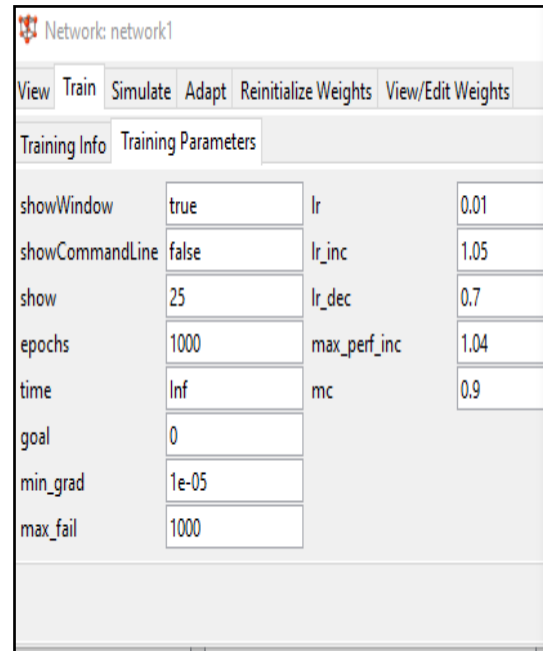

Fig.4.10:-Setting for the training parameters

After the network definition training info and parameters are set and training is done multiple times by checking the regression line values being within the acceptable limits.

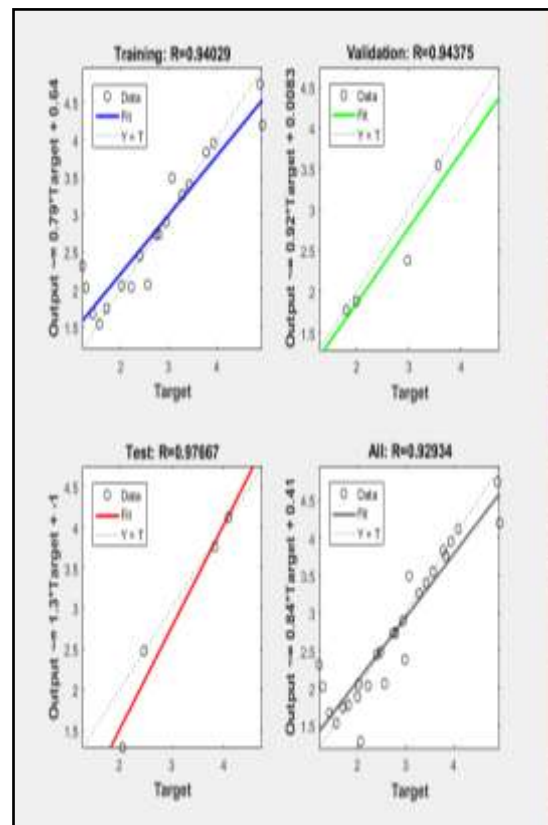

Fig.4.11:-Regression plot for the training of ANN



## V. FUZZY LOGIC:

### 5.1 Introduction to Fuzzy Logic:

Knowledge based systems are systems that are designed to emulate human thinking to solve problems and provide advices. One kind of knowledge based systems is Expert System. Although it is widely used in various applications, such systems are not able to model real world problems which are full of ambiguities and vagueness. When fuzzy logic was introduced by Lotfi Zadeh at 1965, it did not get the attention of expert system's researchers. According to Zadeh, "The initial reception of the concept of a linguistic variable was far from positive, largely because my advocacy of the use of words in systems and decision analysis clashed with the deep-seated tradition of respect for numbers and disrespect for words". The idea of fuzzy logic was to show that there is a world behind conventional logic. This kind of logic is the proper way to model human thinking. Although it has been introduced forty years ago, fuzzy logic is recently getting the attention of artificial intelligence researchers. It is being used to build expert systems for handling ambiguities and vagueness associated with real world problems. The expert system that uses a collection of fuzzy sets and rules to facilitate reasoning is called a Fuzzy Expert System.

Fuzzy logic was developed by Lotfi Zadeh a professor at the University of California, Berkley. It is useful for real world problems where there are different kinds of uncertainty. One kind of uncertainty is fuzziness that is no sharp transition from complete membership to non-membership. In human reasoning much of the logic is not based on two values, it is not even multi-valued but fuzzy truth. In conventional logic everything is considered true or false, black or white but nothing in between. Fuzzy logic on the other hand takes into consideration all values in between.

**5.2 How it Works:** In a fuzzy expert system, the process of reasoning consists of three steps.

**5.2.1 Fuzzification Process:** According to fuzzifying has two meanings. The first is the process finding the fuzzy value of a crisp one. The second is finding the grade of membership of a linguistic value of a linguistic variable corresponding to a fuzzy or scalar input. The most used meaning is the second. Fuzzification is done by membership functions.

**5.2.2 Inference Process:** The next step is the inference process which involves deriving conclusions from existing data. The inference process defines a mapping from input fuzzy sets into output fuzzy sets. It determines the degree to

which the antecedent is satisfied for each rule. This results in one fuzzy set assigned to each output variable for each rule. MIN is an inference method. According to MIN assigns the minimum of antecedent terms to the matching degree of the rule. Then fuzzy sets that represent the output of each rule are combined to form a single fuzzy set. The composition is done by applying MAX which corresponds to applying fuzzy logic OR, or SUM composition methods.

**5.2.3 Defuzzification Process:** Defuzzification is the process of converting fuzzy output sets to crisp values. According to there are three defuzzification methods used: Centroid, Average Maximum and Weighted Average. Centroid method of Defuzzification is the most commonly used method. Using this method the defuzzified value is defined by:

$$\text{Centroid} = \frac{\int x\mu(x)dx}{\int \mu(x)dx}$$

Where  $\mu(x)$  is the aggregated output member function. In the Average Maximum method, if the maximum grade of membership stretches from  $x_{max1}$  to  $x_{max2}$  then the defuzzified crisp value is computed by:

$$\text{Average Maximum} = (x_{max1} + x_{max2})/2$$

In the weighted average method, uses all local maxima and computes the weighted average by:

$$\text{Weighted Average} = \frac{\sum_{i=1}^n (x_{maxi} * \mu(x_{maxi}))}{\sum \mu(x_{maxi})}$$

That is the average maxima's is computed, multiplied by its grade of membership, and add the products, and divide this sum by the sum of the grades of membership

**5.3 Membership Function Determination:** Membership functions can be defined in many different ways, they include the following:

**5.3.1 Polling:** Asking number of expert to give their point of view on a certain question like "Do you agree that Michael Jordan is tall?". The average of their responses is taken and used to construct the membership function.

**5.3.2 Direct Rating:** Randomly select members of the fuzzy set. The expert is then asked for example "How tall is Michael Jordan".

**5.3.3 Reverse Rating:** In this method, the subject is given a membership degree and then asked to identify the object for which that degree corresponds to the fuzzy term in question. Finding the membership function for the fuzzy set tall by asking individuals to identify a man who they think has degree 0.5 of membership to tall.

5.3.4 Exemplification: Building a membership function from samples. If we would like to define a membership function for tallness, experts would be asked to describe a number of heights using linguistic terms and then assign Linguistic terms to membership values.

**5.4 Fuzzy Rules:**

Fuzzy logic and artificial intelligence

The purpose of fuzzy rule bases is to formalize and implement a human being’s method of reasoning. As such it can be classed in the field of artificial intelligence. The tool most commonly used in fuzzy logic applications is the fuzzy rule base. A fuzzy rule base is made of rules which are normally used in parallel but which can also be concatenated in some applications.

A rule is of the type: IF “predicate” THEN “conclusion”. For example: IF “high temperature and high pressure” THEN “strong ventilation and wide open valve”.

Fuzzy rule bases, just like conventional expert systems, rely on a knowledge base derived from human expertise. Nevertheless, there are major differences in the characteristics and processing of this knowledge. A fuzzy rule comprises three functional parts summarized as shown in Fig.5.1

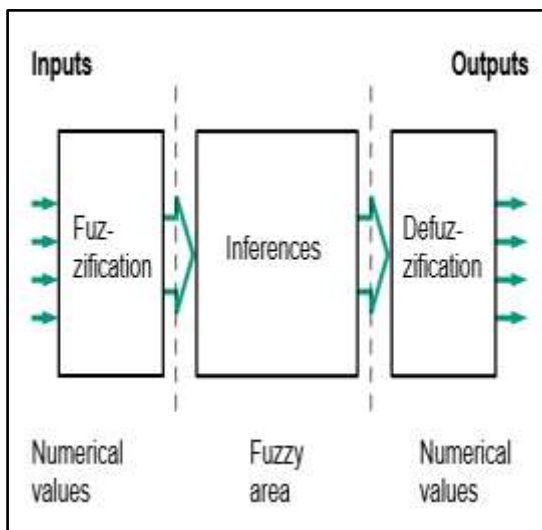

Fig 5.1: Fuzzy Processing

**5.5 Fuzzy Logic procedure:**

The project we decided to do was to create a fuzzy logic system which would model a Surface Roughness for Milling Operation. The system takes in three inputs and gives an output which determines the Surface Roughness. Using this repeatedly, our system was designed to determine Surface Roughness at different Spindle speed, depth of cut and feed rate.

**Inputs**

We decided on three inputs (linguistic variables) for our fuzzy system: Spindle speed, Depth of Cut and Feed Rate.

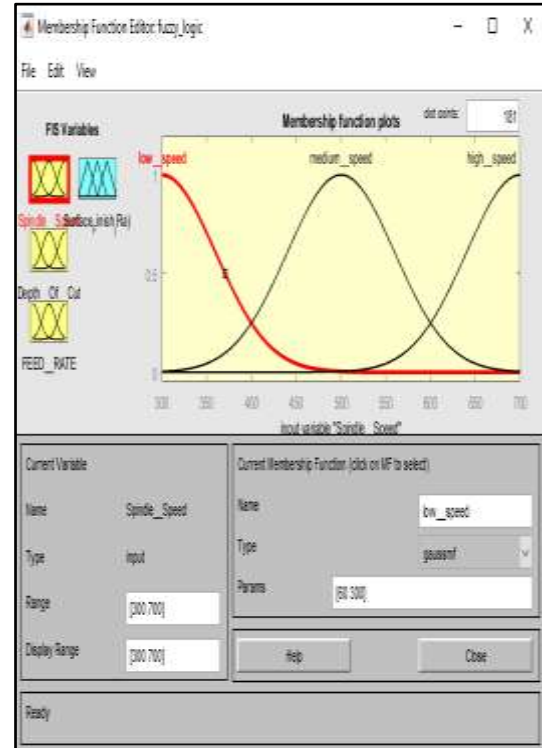

Fig.5.2: Spindle Speed

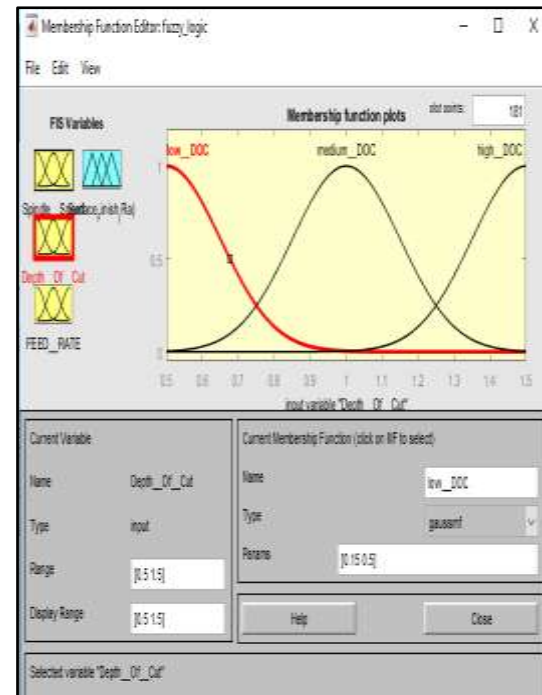

Fig.5.3: Depth of cut

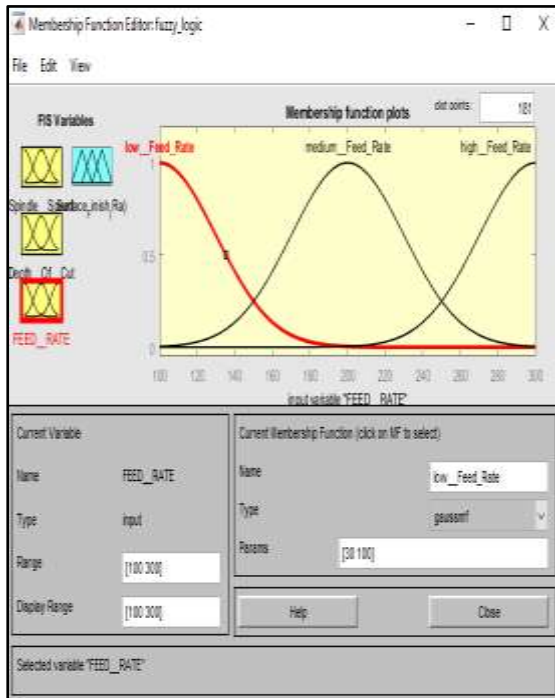

Fig.5.4: Feed Rate

Output Variable: Surface Roughness is output variable in our case.

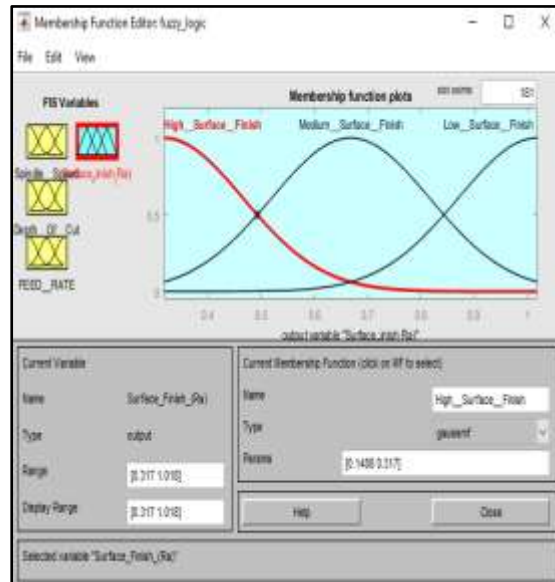

Fig.5.5: Surface Finish

Rules of Fuzzy Logic analysis: Different Rules are given for analysis are given as follows:

“At low Spindle speed, low depth of cut, and low feed rate the surface finish will be High”.

“At Medium Spindle speed, medium depth of cut, and Medium feed rate the surface finish will be Medium”.

“At High Spindle speed, High depth of cut, and High feed rate the surface finish will be Low”.

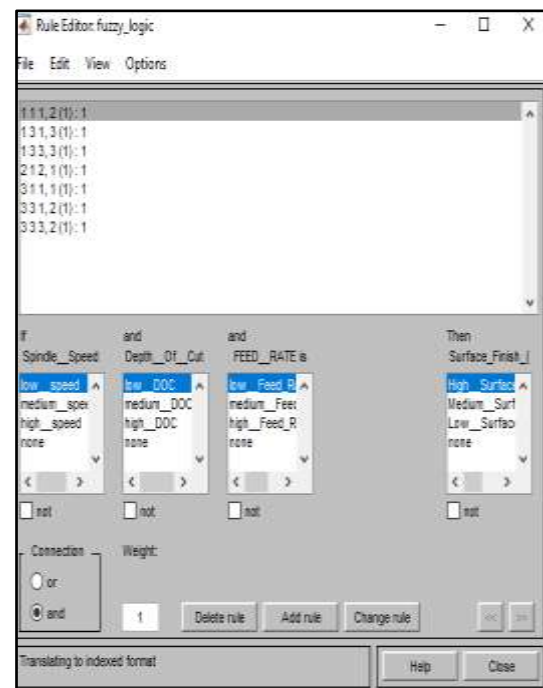

Fig.5.6. Rules

### 5.5 Result of Fuzzy Logic:

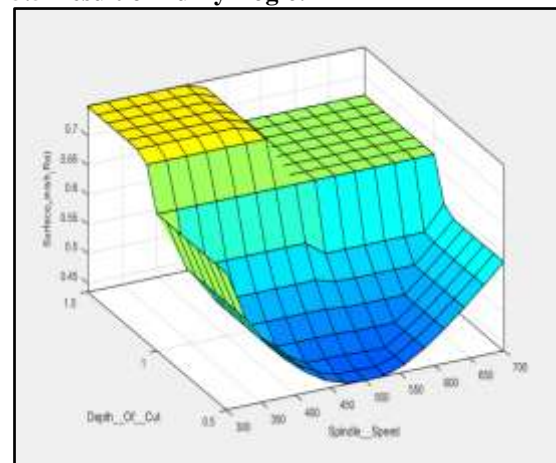

Fig.5.7: Result Surface plot of Fuzzy Logic

The Fig5.7. Shows the Variation of Surface finish with variation of input parameters like Spindle Speed, Depth of cut and Feed Rate.

### VI. RESULTS AND DISCUSSION

Source	DOF	SS	Mean Sq.	F	P	% Contribution
SS RPM	2	0.336	0.01668	1.48	0.252	4.77
DoC	2	0.42924	0.21462	19.03	0.000	61.49
Feed Rate	2	0.00993	0.00496	0.44	0.650	1.42
Error	20	0.22553	0.01128			32.30
Total	26	0.69806				

Table 5:-ANOVA results for Full Factorial –Ra

From the Tables-5 it is clear that cutting parameter - feed rate has no significant effect on surface roughness  $R_a$ , spindle speed has more significant effect and depth of cut has more significant effect on surface roughness  $R_a$ .

Results of comparison of full factorial DoE and Taguchi DoE shows that both the cutting parameter influence results obtained for surface roughness are close to each other and there is more improvement in percentage of DoC-93% on Surface Roughness with minimum or optimal number of experiments conducted using Taguchi DoE method. Hence Taguchi DoE is best suited for conducting experiments.

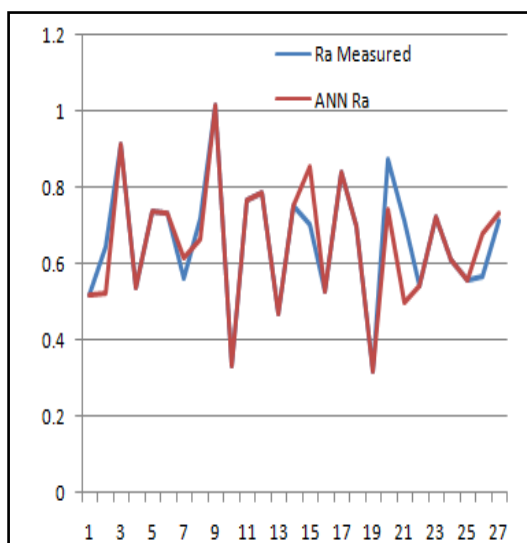

Fig.5.1:- ANN Ra and Ra measured graph

from the ANN graph in Figure, that in most cases, the neural network prediction is very close to the

measured values i.e up to 75%, to get better surface roughness prediction more number of readings need to be fed to the neural network designed during the training and testing of network.

Table.6:- ANN for Surface Roughness output

Expt No.	Ra Measured	ANN Ra	Error in Ra
1	0.518	0.518	-0.000004%
2	0.646	0.5252964	12.070356%
3	0.917	0.917	-0.000003%
4	0.538	0.538	0.000000%
5	0.737	0.7369998	0.000021%
6	0.732	0.732	0.000001%
7	0.563	0.6153174	-5.231737%
8	0.718	0.6648887	5.311133%
9	1.018	1.0179986	0.000142%
10	0.33	0.3300001	-0.000011%
11	0.767	0.7669998	0.000019%
12	0.789	0.789	0.000000%
13	0.471	0.4710001	-0.000008%
14	0.752	0.7520002	-0.000016%
15	0.704	0.8580398	-15.403983%
16	0.529	0.5290002	-0.000016%
17	0.842	0.842	0.000004%
18	0.7	0.7000014	-0.000144%



19	0.317	0.3169999	0.000006%
20	0.877	0.7444666	13.253336%
21	0.713	0.4977082	21.529176%
22	0.543	0.5430001	-0.000007%
23	0.726	0.7260001	-0.000010%
24	0.612	0.6120002	-0.000017%
25	0.559	0.5590001	-0.000008%
26	0.565	0.6776598	-11.265984%
27	0.713	0.7315262	-1.852624%

Table shows the ANN output prediction of the surface roughness for all the observations we have performed testing on. Fig. Error Histogram is shown in the image above.

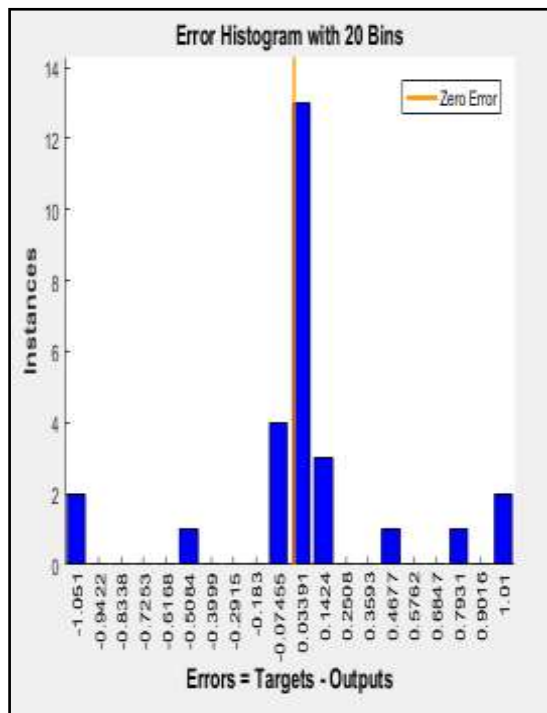

Fig.5.2:- Error histogram ANN

Result of Fuzzy Logic:

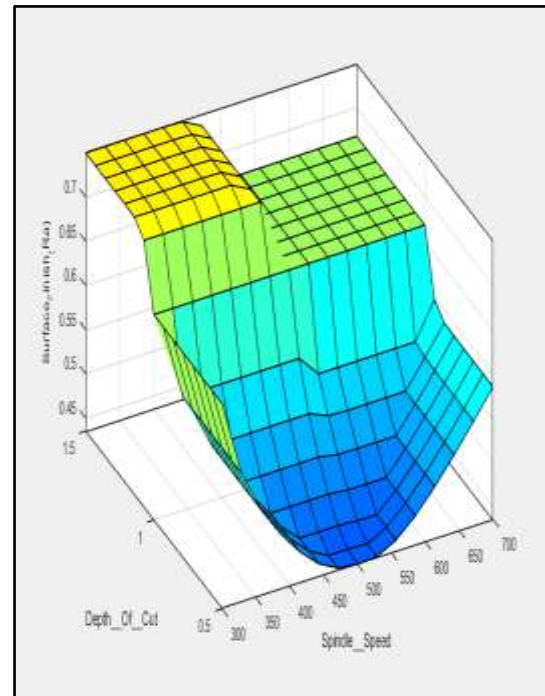

Fig.5.7: Result Surface plot of Fuzzy Logic

The Fig5.7. Shows the Variation of Surface finish with variation of input parameters like Spindle Speed, Depth of cut and Feed Rate.

## VII. CONCLUSION

This work describes the method involved to acquire and predict the surface roughness and optimize the cutting parameters on the milling machine tool under cutting conditions such as depth of cut, feed rate and spindle speed in milling machine. Taguchi is the best Design of Experiment (DoE) method to achieve the optimum number of solutions.

The results show that with the increase in spindle speed there is a decrease in surface roughness value up-to 500 RPM. A RPM of 300 produces the highest roughness and 700 RPM shows the lowest one, i.e. the best surface finish. In the figure the optimum value for feed was 100 mm/min and for depth of cut was 0.5 mm.

In the present work has been made to find a technique for optimizing machining parameter that could yield minimum machining time at the same time maintaining the desired surface roughness and MRR. Surface roughness value confidence level for the adequacy process occurs at cutting speed of 700rpm, feed rate of 100mm/min is 0.317µm. Artificial neural networking is successfully studied and implied to the model and results of the surface finish predicted by ANN relation are in conformance with the observations

made by actual testing with the error of maximum 21.52 %.

## 7. FUTURE SCOPE

The present work can be extended for various materials such as En8, En9, etc, for different process parameters at different levels with different cutting oils. In the present work there is no consideration of tool insert. For future scope various types of inserts with nose radius can be considered.

## REFERENCES

- [1]. “A Study of the Effects of Machining Parameters on the Surface Roughness in the End-Milling Process” presented by Mohammed T. Hayajneh, Montasser S. Tahat, Joachim Bluhm, 2007.
- [2]. “A Parametric Design Study of End Milling Operation using Grey Based Taguchi Method” presented by Abhishek Dubey, Devendra Pathak, Nilesh Chandra, Ajendra Nath Mishra, Rahul Davis, 2014.
- [3]. “Modeling and optimization of end milling parameters on aluminum 6061 alloy using GRA based Taguchi method coupled with PCA” presented by Rajesh Kumar, M.K. Pradhan, Rishi Kumar, 2014.
- [4]. “Optimization of End Milling Process Parameters for Minimization of Surface Roughness of AISI P20 Steel” by Wasim Khan, Niyati Raut, 2016.
- [5]. “A study on the machining parameters optimization of micro-end milling process” by P. R. Periyanan, U. Natarajan, S.H. Yang, 2011.
- [6]. “Multi-Response Optimization Using ANOVA and Desirability Function Analysis: A Case Study in End Milling of Inconel Alloy” by R. Ramanujam, 2015.
- [7]. “Gray Relational Based Analysis of Al-6351” by A. R. Lande, S.B. Patil, 2015.
- [8]. “Investigation of Optimum Cutting Parameters for End Milling of H13 Die Steel using Taguchi based Grey Relational Analysis” by Harshraj D. Wathore, P.S. Adwani, 2015.
- [9]. “Parametric Optimization of Temperature during CNC End Milling of Mild Steel Using RSM” by Bhargav Patel, Hardik Nayak, Kamlesh Arania, Gaurang Champaneri, 2014.