

# Design and Development of a Smart Incubator System

<sup>1</sup>Sanusi Mohammed, <sup>2</sup>Dr. Danlami Mohammed, <sup>3</sup>Maria Musa Mukaddas, <sup>4</sup>Nuhu Mohammed

<sup>1</sup>Department of Electrical Engineering, Abubakar Tatari Ali Polytechnic Bauchi, Bauchi State, Nigeria

<sup>2</sup>Department of Computer Science, Abubakar Tatari Ali Polytechnic Bauchi, Bauchi State, Nigeria.

<sup>3</sup>Department of Quantity Surveying, Abubakar Tatari Ali Polytechnic Bauchi, Bauchi State, Nigeria.

<sup>4</sup>Department of Surveying and Geoinformatics, Abubakar Tatari Ali Polytechnic Bauchi, Bauchi State, Nigeria.

Date of Submission: 02-06-2026

Date of Acceptance: 13-06-2026

## ABSTRACT

An incubator is a technology used for automated and efficient egg production. The work is aimed at developing an egg incubator system capable of incubating various types of egg within the temperature range of 37.5 – 40°C. This system uses temperature and humidity sensors that can measure the condition of the incubator and automatically change to the suitable condition for the egg. However, in its development, existing egg incubators only utilize incandescent lamps without any notification system to indicate when the chicken eggs have hatched, and there is no temperature or humidity detection in the incubator. As a result, the incubator's situation during the egg hatching process remains uncontrolled. This research work designed and developed an egg incubator system using a microcontroller as the main control unit, for regulating temperature, humidity, and egg rotation. This is connected to the internet as a communication tool using specialized software, allowing farmers to remotely monitor the system. Users receive information about the incubator machine through the Telegram mobile application, such as the current temperature and humidity inside the incubation room, up to the hatching status of the eggs. The hardware was successfully developed using the Microcontroller. The device functioned effectively which includes temperature and humidity readings, controlling the timing of the lamp, and shifting the egg tray. The performance test of the device successfully hatched eggs on time (for 21 days) and the success rate recorded was 94%.

**Keywords:** Design, Development, Smart, Egg incubator system.

## I. Introduction

Food is one of the fundamental necessities that people require, ranking first, followed by clothing and shelter, which rank third. Human beings require what they eat to be nutritionally balanced with components of carbohydrates, protein, fats, oils,

minerals, etc. There are numerous ways to obtain carbohydrates from tuber crops and other plants, which are easily assessed even in many of the world's poorest regions. Proteins, which are very important for healthy growth, can be obtained from both plants and animals.

Incubation is the process of keeping the fertilized eggs warm in order to allow proper development of the embryo into a chick. It may either be natural or artificial. In natural incubation, the bird provides the required conditions for the relatively few eggs she lays by sitting on the eggs intermittently until they hatch in an open space. An artificial incubator is a chamber in which temperature, humidity and ventilation are controlled for the purpose of hatching a relatively large number of eggs than a single hen can handle at a time [1]. The heat required for incubation is usually provided by coal, oil, gas or electricity.

Smart egg incubator can approximate the characteristics of a bird during the incubation process. Such an incubator is designed to create and maintain specific temperature conditions for optimal embryo development at any given moment. The temperature set-point may be adjusted slightly to suit the conditions. It is universally agreed that maintaining an appropriate level of humidity is also significant. The right temperature provides sufficient heat necessary for embryo development. However, determining the exact temperature required at any given moment of incubation can be challenging due to several factors, including air speed within the incubator, heat distribution in the surrounding air, the nature of thermal conductivities of eggshells, and the different stages of embryo development.

This research work will promote and encourage the production of eggs by providing a machine that will increase the scale in eggs production process at an affordable rate. The development of automatic eggs incubator will increase the market value and thus, boosting the agricultural industries and improving Nigeria foreign exchange by contributing to Nigeria's Gross

Domestic Product (GDP). This research will encourage the local contents produced in our local environment and therefore, minimize the rate of importation of machines which dwindle the nation foreign reserve. The research work is based on design and development of an automated egg incubator capable of maintaining and regulating the temperature, humidity and turning angle of the eggs throughout the incubation period. The system was powered by solar system with maximum capacity to incubate 792 eggs.

#### A. Problem Statements.

The world's population is growing at an alarming rate and so is the demand for protein especially in the rural areas, poultry is a good source of protein and it is affordable. A broody hen (a hen that wants to set and hatch eggs and raise the chicks) can hatch just about 10-12 eggs at once in 21 days, which reduces its productivity as it takes time to incubate and hatch the chicks. For the world growing population, relying on this natural type of incubation is not enough, hence the need for artificial incubation. This way, a female bird just concentrates on laying eggs while the incubation is done for her artificially.

#### II. RELATED WORKS

Kocher and Izadeen (2022) designed and implement a microcontroller-based incubator system that automatically regulate temperature and humidity. The study highlighted the use of sensors, heating elements and control circuits to improve hatchability rates compared with manual incubation methods.

Ohemu et al., (2021) developed a Smart egg incubator equipped with DHT 22 temperature and humidity sensors and an automatic transfer switch for power management. The system maintained suitable incubation conditions and reduced human intervention through automated monitoring and control.

Santosa et al., (2025) proposed an IoT-enabled incubator using an ESP 32 microcontroller and the Blynk platform. The system provided real-time monitoring of temperature, humidity, hatching sounds and video feeds through a Smart phone application. This work demonstrated the effectiveness of IoT in enabling remote supervision of incubation processes.

Peprah et al., (2022) designed a solar-powered Smart incubator integrated with GSM and IoT Technologies. The system addressed challenges associated with unreliable electricity supply and enabled remote monitoring of incubation parameters, making it suitable for rural poultry farmers.

Ariagbofo et al., (2026) developed an IoT-enabled automatic incubator powered by solar energy. The system utilized an ESP 32 controller, DHT 22 sensors, ventilation fans, and servo mechanisms to maintain optimal environmental conditions. Results showed stable temperature and humidity control suitable for successful egg hatching.

Wahyuni et al., (2025) developed a smart incubator that incorporated IoT and Artificial Intelligence using a Mamdani Fuzzy Logic Controller. The system automatically adjusted temperature and humidity while providing real-time monitoring through mobile devices. Their findings showed improved hatchability and environmental control compared to conventional incubators.

#### III. MATERIALS AND METHODS

The design involves both hardware and software. The hardware was implemented using modular design method while the software developed using embedded C language. The following materials were used:

- I. Temperature sensor
- II. Humidity sensor
- III. Light controller
- IV. Humidifier
- V. Power supply
- VI. Inverter
- VII. Egg tray
- VIII. Turning mechanism
- IX. Fan
- X. Heating system
- XI. Solar battery
- XII. An egg roller

#### A. Design and Construction

- Structure: A cuboidal chamber ( $0.38 \times 0.35 \times 0.45$  m) with a hinged door for egg loading.
- Heating System: Halogen bulb regulated via PWM (Pulse Width Modulation) for energy efficiency.
- Humidity Control: Water tray with a wick system and optional ultrasonic humidifier.
- Airflow: DC fan ensures uniform heat distribution.

#### B. System circuit connection

System Circuit and connections. The relay circuit consists of four relays each rated 6V, 10A; four 100Ω resistors; four 802 Ω resistors; and four IN4001 diodes. All of them were wired on a PC board. The relays are triggered using a 2N2222 n-p-n transistor actuated by the control signal from the Arduino microcontroller. Two relays are used for switching two of incandescent lamps to a 240 V supply, blower fans and switching the gear motor for operating the

tray turning mechanism respectively. The connection between the various elements making the circuit is shown in Figure 5. The diode rectifier circuit which takes its source from the secondary of the stepdown

transformer, serves as a DC supply for the microcontroller. The circuit was simulated and tested with a software called 'Circuit Maker' as shown in Figure 6, before real time implementation.

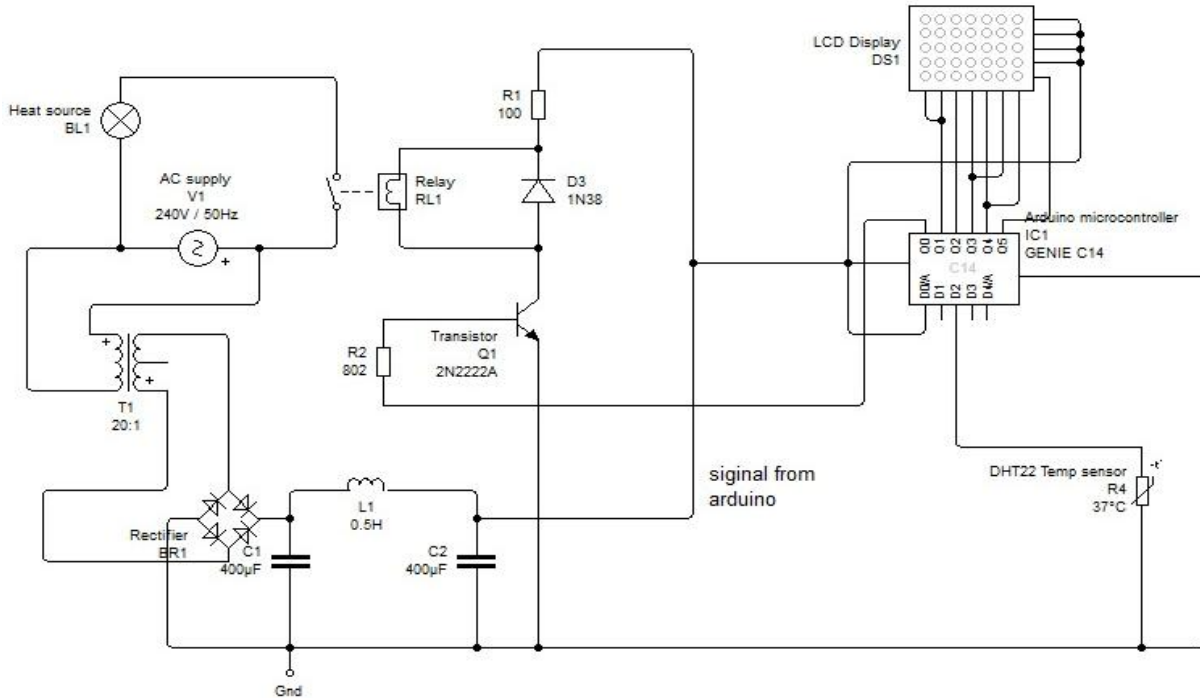

Figure 1: Incubator heat control circuit diagram

### C. The power module

The power module supplies power to the whole circuit, it supplies both the 12V which drives the relays and the 5V needed by the sensor, microcontroller and other components. This module is made up of a transformer, a bridge rectifier, an

electrolytic capacitor, and two regulators. 1) Transformer: The type of transformer used is a simple step-down transformer with primary voltage of 220V/50Hz, a secondary voltage of 12V and a current of 1000mA (which is greater than the current requirement of the circuit).

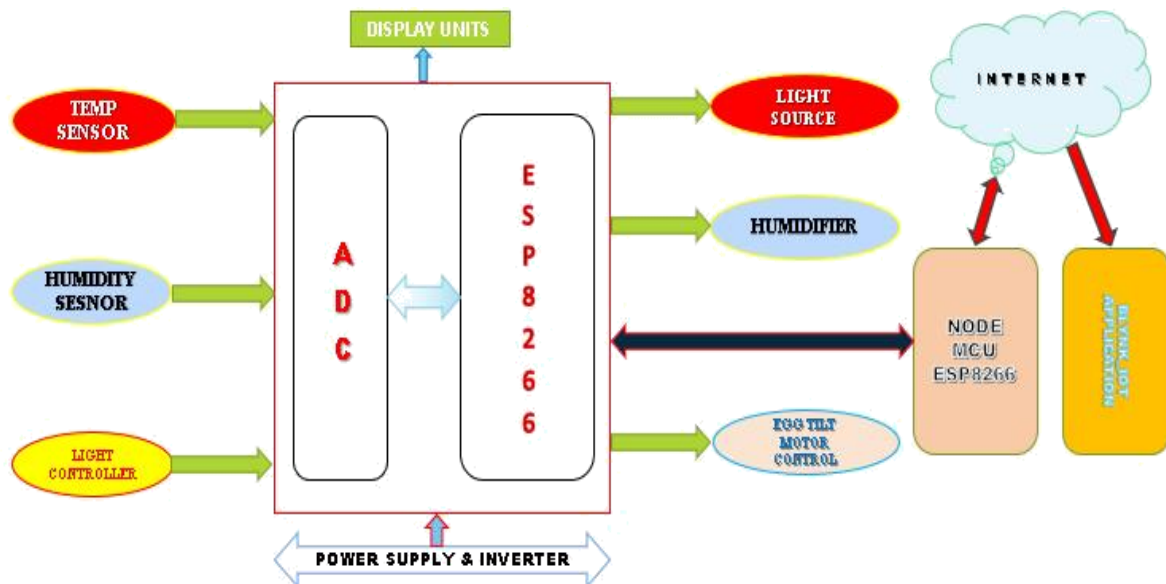

Fig. 2: Block diagram of the system

#### D. Working principles of the system

The nucleus of the female cell is a small white or light-colored speck about the size of a pinhead that is located on the top side of the yolk. Here the microscopic male sperm cell finds lodgment and the cells are united to form the embryo. A fertilized egg is characterized by a white ring 3-4 millimeters in size on the yolk surface (germ cell), whereas an infertile egg is characterized by a single white speck of about 2-3 mm diameter.

#### E. Fertile Egg Storage

Fertile eggs should be clean and dry and stored between 12-15°C at a relative humidity of 75% with the small end down. Eggs should be turned by 90 degrees at least once to twice daily. Optimal hatchability is achieved in fresh eggs less than 10 days old, but reasonable hatchability can be obtained in eggs up to 14 days of age. Fertile eggs should maintain a relatively constant weight with minimal

weight loss during storage. Temperatures above 25°C can initiate cellular replication of the germ cell on the yolk of the fertile egg and will increase embryonic mortality and reduce hatchability. Temperatures below 10°C can inactivate the germ cell.

F. Principles of Artificial Incubation of Fertile Eggs  
The four main essentials of incubation of good quality fertile eggs are:

- Correct and even temperature controlled by a thermometer or thermocouple
- Correct humidity controlled by ventilation rate and water application
- Correct oxygen and carbon dioxide concentrations controlled by ventilation
- Turning of the fertile eggs by approximately 90 degrees several times per day by manual or automatic means.

These parameters can be easily achieved and maintained if the incubator manufacturer's operating instructions are carefully adhered to.



Fig. 3: Fertile eggs

Incubation Temperature Range and Variation. The temperature requirements for incubation and most incubators have a temperature variation of 0.2-0.4°C for effective incubation and subsequently a high hatchability rate. Embryo tolerance to temperatures more than 1°C above or below the recommended temperature is low, and temperatures outside this range will result in significant embryonic mortality. Embryos are much more susceptible to temperature variation in the early and late phases of incubation.

#### IV. Incubator working principle

The thermo-electricity theory, which states that heat or thermal energy can be converted into electrical energy, is the foundational idea behind an incubator. Every incubator operates under the fundamental element that microorganisms need the ideal environment to live and grow. The perfect temperature, humidity, oxygen, and carbon dioxide are all present in an incubator, allowing the microorganisms to grow and increase in population. An incubator's thermostat controls the temperature within the incubator. We can use the thermometer to check this temperature outside. We keep the

temperature within the incubator constant by heating and no heating cycles. In the heating cycle, the incubator's temperature is raised by the thermostat, but in the non-heating process, the incubator is cooled by radiating heat outward. The cabinet has a system of insulation that keeps it isolated from the outside

and promotes efficient microbial growth. Similarly, the incubator also maintains other conditions necessary for the development of the organisms, such as humidity, ventilation, CO<sub>2</sub> concentration, and pH, using various processes.

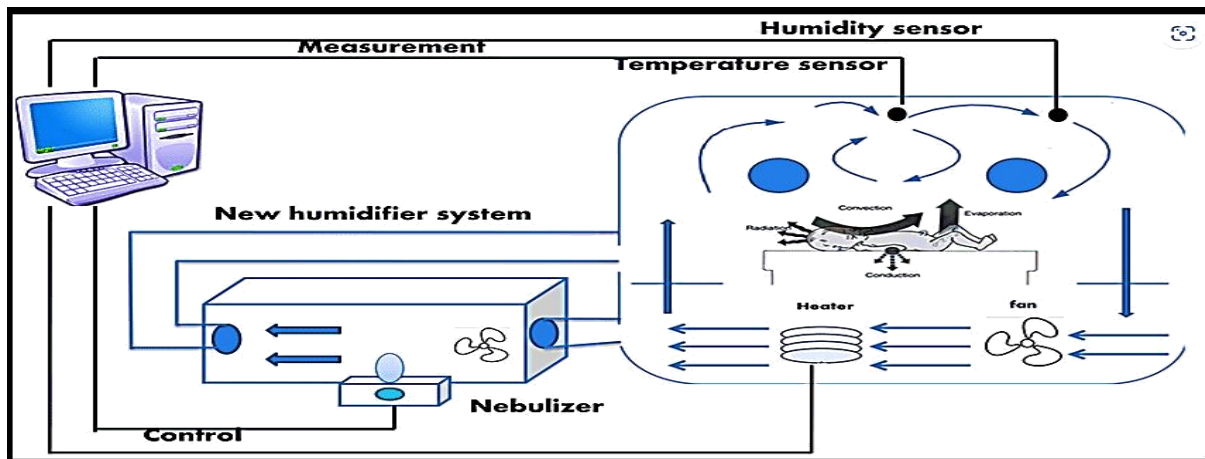

Fig. 4: Incubator working principle

In general, the incubation process involves placing the biological material inside the incubator and setting the desired environmental conditions. The incubation system will then monitor and maintain the conditions inside the chamber to ensure optimal growth and development of the organism.



Fig. 5: Egg Tilt Tray

The positioning of eggs in an incubator is important for proper development of the embryos inside the eggs. Here are some guidelines for proper egg positioning: Place the eggs with the pointed end down: When you place the eggs in the incubator, make sure to position them with the pointed end down. This helps the air sac to be in the correct position and allows the embryo to develop properly. Use an egg turner: An egg turner is a device that turns the eggs automatically, ensuring that the embryos develop uniformly.

## V. Turning

Turning is essential during the first 14 days of incubation, but most people continue it to day 18. Turning is stopped during the last 3 days. If you're hand turning and not using an automatic egg turner, always turn the eggs an uneven number of (minimum 3) times a day, so the eggs do not spend two nights in a row in the same position.

If not turned to a fresh position frequently during the early stages, the developing embryo touches the shell membrane and sticks to it causing abnormal growth. Turning the egg aids these movements within the egg, and mimics what a mother hen would do naturally. Turning the eggs in an incubator is important for the healthy development

of the embryos inside the eggs. Turning helps prevent the embryo from sticking to the inside of the shell and promotes the development of the circulatory and skeletal systems.

### VI. Results

The primary resultant of a chicken egg incubator is the successful hatching of chicks from

fertilized eggs. This is achieved by providing optimal incubation conditions such as temperature, humidity, and egg turning, which promote embryo development and hatching. In addition to hatching chicks, an egg incubator can also result in other benefits, such as increased efficiency and control over the incubation process.



Fig. 6: Experimental Result of Chicken egg incubator

### VII. Simulation Results

The entire system which is made up of controller, actuator, incubation chamber and sensors were modeled and validated via simulation using Matlab /Simulink. In the course of the simulation, several parameters of the PID temperature control

were tuned employing Ziegler Nichol tuning method in order to ascertain the values of the parameters that gave the desired transient response of the system when subjected to a unit step input. The simulated results of the system control with PID tuning were analyzed. Figure 1.4 shows the simulink block diagram of the incubation system.

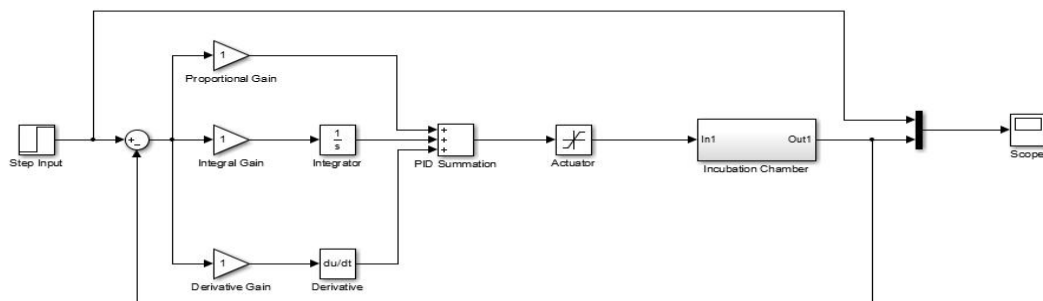

Fig.7: Simulink Block Diagram of the incubation temperature control system

TEST 1: Consider the following assumed values of the parameters of the PID controller and the response of the system to these values

TABLE 1: The first assumed values of the PID temperature control parameters

Parameter	$K_p$	$T_i$	$T_d$
Values (sec)	0.2850	0.1170	0.3626

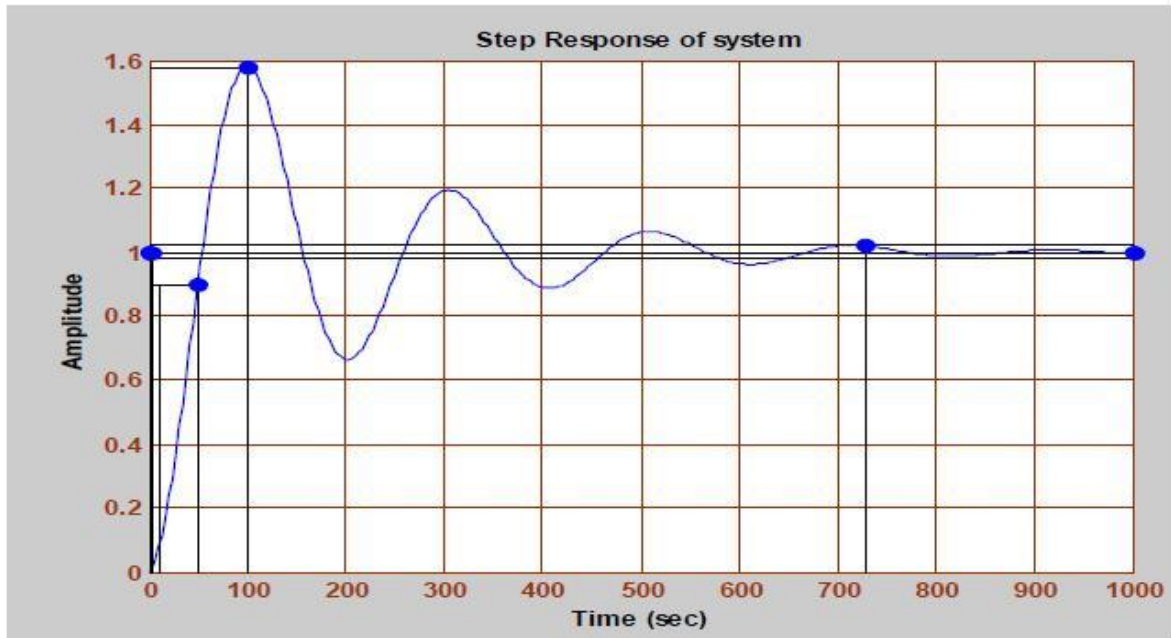

Fig. 8: Scope of the unit step response of the system for test 1

TABLE 2: Result of test 1

parameter	$T_r$ (sec)	$T_p$ (sec)	$T_s$ (sec)	$M_p$ (%)
Values	37.8	100	728	58

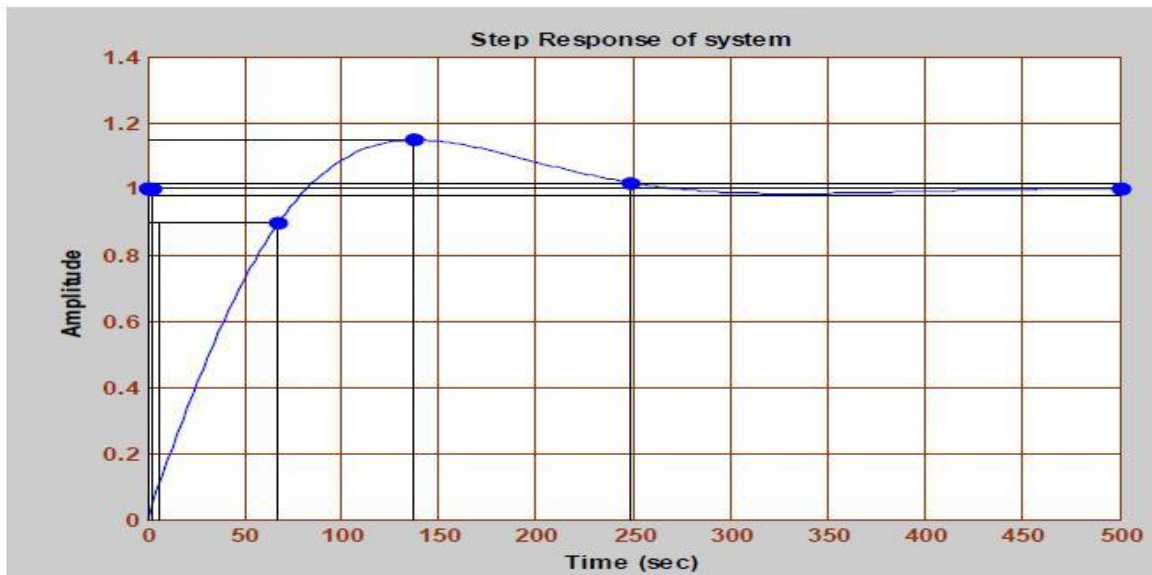

Fig. 9: Scope of the unit step response of the system for test 2

### Analysis

Using Matlab/Simulink toolbox, various parameters were tested and the best parameters were used for PID implementation on the microcontroller. The results showed the system responses to a step input with varying PID temperature control parameters based on Zeigler-Nichols tuning method. It can be inferred from the results that the optimal set of parameters that gave a more desirable transient response in terms of short rise time, low overshoot, short settling time, low steady state.

### VIII. Conclusion

This work develops a model, design and simulation of a temperature control of a smart egg incubator system for various types of egg. Keypad was incorporated in the system which allows the operator to key in the temperature value within the range of 35- 40°C, depending on the type of egg to be incubated. Temperature was measured using LM35 Ic and its value displayed at the LCD. 4-relays were used for the switching of the incandescent lamps, fan motor and DC motor. Weight sensor was used to monitor the weight of egg in the incubator.

### IX. Recommendations

After analyzing the results obtained from testing, the following recommendations were made for future work:

- i) A good heater and cooler can be used to improve performance in terms of response time and stability of the system.
- ii) Employing the power of modern-day network capabilities to remotely control the system will also be considered as an improvement on the work.
- iii) The system can also be extended in functionality by adding other related sensors to it so that it can measure as well as regulate other physical properties like pressure and humidity.
- iv) Using progressive control instead of on/off control for the fan and the cooler can be used to reduce the settling time of the system.
- v) Making the set point to accept temperature ranges instead of a fixed temperature value will make the system more functional and also eliminate unnecessary oscillations when on/off control is used as the temperature reaches the set point.

### REFERENCES

- [1]. Reijrink, I. A. M., Berghmans D., Meijerhof, R., Kemp, B., and Hvanden, B. (2018). Influence of Egg Storage Time and Pre-incubation Warming Profile on Embryonic Development, Hatchability, and Chick Quality, Poultry Science Association Inc, Pp. 1225-1238.
- [2]. Shittu, S., Abubakar, S., Muhammed, M., Jimoh, A., Sani, M., and Jimoh, N.O. (2017): Development of an Automatic Bird-Egg Incubator. Research and Reviews: A Journal of Embedded System and Application. ISSN: 2395-6712 (online), ISSN: 2321-8533 (print) Volume 5, Issue; Pp 1-10.
- [3]. Abiola, S.S., Bala, A.M. (2020). Effect of Turning Frequency of Hen's Eggs in Electric Table Type Incubator on Weight Loss, Hatchability and Mortality. African Journal of Biotechnology. 7(23):4310-4313.
- [4]. Benjamin, N., and Sambo, L. (2017) Modification of the Design of Poultry Incubator. International Journal Application or Innovation in Engineering and Management (IJAEM). 1(4): 90-102.
- [5]. M. Anang Sucipto and S. Bagus Prakoso, "Rancang Bangun Alat Penetas Telur Otomatis berbasis Arduino," J. FORTECH, vol. 3, no. 1, pp. 43-50, 2022.
- [6]. G. Agyekum, M. A. Okai, J. K. Tona, A. Donkoh, and J. A. Hamidu, "Impact of incubation temperature profile on chick quality, bone, and immune system during the late period of incubation of Cobb 500 broiler strain," Poult. Sci., vol. 101, no. 9, p. 101999, Sep. 2022.
- [7]. H. van den Brand et al., "Interaction between eggshell temperature and carbon dioxide concentration after day 8 of incubation on broiler chicken embryo development," Animal, vol. 15, no. 6, p. 100223, Jun. 2021.
- [8]. F. Hendajani, A. Mughni, I. P. Wardhani, and A. Hakim, "Modeling Automatic Room Temperature and Humidity Monitoring System with Fan Control on the Internet of Things," ComTech Comput. Math. Eng. Appl., vol. 13, no. 2, pp. 75-85, 2022.
- [9]. Y. A. Ahmad, T. Surya Gunawan, H. Mansor, B. A. Hamida, A. Fikri Hishamudin, and F. Arifin, "On the Evaluation of DHT22 Temperature Sensor for IoT Application," Proc. 8th Int. Conf. Comput. Commun. Eng. ICCCE 2021, pp. 131-134, 2021.
- [10]. Ramesh Saha, S. Biswas, S. Sarmah, S. Karmakar, and P. Das, "A Working Prototype Using DS18B20 Temperature Sensor and Arduino for Health Monitoring," SN Comput. Sci., vol. 2, no. 1, pp. 1-21, 2021.