

“Design of Automatic Sewage Cleaning Machine”

Magi Prasad Dattatray, Ingale Pratik Vasantrao,
Sathe Akshay Sunil, Kumbhar Ganesh Naganath

*UG Students, Department of Mechanical Engineering,
SVERI's College of Engineering, Pandharpur-413304, MH, India
Prof. B. T. Gadade Sir*

*Assistant Professor, Department of Mechanical Engineering,
SVERI's College of Engineering, Pandharpur-413304, MH, India*

Submitted: 25-06-2021

Revised: 01-07-2021

Accepted: 03-07-2021

ABSTRACT

The purpose of this project is to replace manual sewage (drainage) cleaning system to automatic machine. Due to this process workers will feel safe nowadays and healthy. In drainage we can see many solid wastages are collected at one place so to remove this wastage automatic drainage cleaning machine is used without any man power. It is semi-automatic machine helps to remove solid wastage easily. Also cost of this machine is less and easy to handle.

This project is designed with the objective to initiate the efficient working of system. This project automatically cleans the water in the drainage system each time any impurity appears which are driven by chain sprocket grasp the solid waste and throw it into the waste bucket called as collecting bin to avoid blockage. It reduces cost of manual worker, labor as well as reduce risk of human life.

So, we designed an "Automatic Sewage Cleaning Machine" having dimensions millimeters (740mm x 650mm x 1208mm and thickness is 20 mm). Material used for this is Stainless steel. Main frame is designed by using steel.

I. LITERATURE REVIEW

In today era cleaning of water is main and primary purpose. But cleaning of water is done manually till now. When human cleans the gutters, sewage manually then there will be loss of risk or health issue which damage human health. So we have come with one automatic machine which cleans these all sewage and gutters automatically without any help of labor, humans and risk of these humans life is getting less.

1. **R. Sathiyakala**, explained E bucket (electronic bucket) use for drainage cleaning system because E-bucket lifted a sewage and used evaporation treatment for this sewage wet sewage
2. **Ganesh U L**, showed the usage of mechanical drainage cleaner to exchange the manual work required for drainage cleaning system. Drainage pipes are very dirty. Sometimes it's harmful for human life while it's need for cleaning system. To overcome this problem, they implemented mechanical semi-Automated drainage water cleaner and so the water flow is efficient because of regular filtration of wastages with the help of that project. Different sorts of environment hazards reduced with the assistance of system machine.
3. **Dr.k. kumaresan**, explained about how manual work is converted to automated system. Drainage pipe using for disposal and it's going to be loss for human life while cleaning the blockage within the drainage pipes. To overcome this problem, they implemented "Automated Sewage (gutter) Cleaning Machine". They designed their project different way clearance of gaseous substance are treated separately therefore the flow of water efficiently. This project could also be developed with the complete utilization of men, machines, and materials and money. They made their project efficient and economical with the available resources. They used automation technology related together with his application of mechanical, electronics, computer-based systems to work and control production.

4. **Nitin Sall**, explained flow of used water from homes, apartments, business industries, commercial activities is called waste water. 300 and 400 L wastage water are generated each person every day. So, using waste water technology that removes instead of destroys a pollutant during a system.
5. **James C. Conwell, G. E. Johnson**, proposed the planning and construction of a replacement test machine configuration that gives same advantages over the normal one. The new machine and attendant instrumentation provide more realistic chain loading and permit link tension and roller sprocket impact monitoring during normal operation. The incorporation of idle sprocket allows independent adjustment of test on length and preload.
6. **S D Rahul Bharadwaj**, proposed with the automatic cleaning of waste water to prevent global warming and melting of glaciers. The results emphasize the necessity of waste water treatment plants, through which the water is treated before suspending in rivers. Firstly, power is generated and that same power is used for waste water cleaning process.
7. **Ndubuisi.C. Daniels**, showed the drainage system cleaner machine used to remove garbage and sewage automatically which will help to protect the environment from different kinds of environmental hazards also control water pollution. The system cleaner has three major parts which are the Propeller, the Cleaner and therefore the Pan all makes up for its effective functioning.
8. **Balachandraetal**, reviewed about drainage cleaning to exchange manual work to automated system because manually cleaning system it's harmful for human life and cleaning time, is more so to beat this problem they implemented a design "Automated drainage pump monitoring and system" using PLC and SCADA. PLC and SCADA were designed.

II. INTRODUCTION

Water is being used very fast in today. The significance of water is mainly used for drinking, cooking and cleaning in our lifestyle. The water is been used in the factory and the house comes from the drains and reach into the rivers, in the ponds and in the oceans. In which more solid ingredients (like polythene, bottles etc.) along with water also reaches. We have been built "Automated

drain cleaning machine" with the main purpose of removing those solid materials from drains. This machine can be established at any point of drain(gutter) easily. It has been Design in such a way that lets water flow through it but collects all the solid substances in collecting bin and gives a group in the dustbin. This machine is able to do cleaning and moving process together in the drains/gutters.

This can be used for to overcome the problem of filtration of waste from water and it can save the time and cost that spend on cleaning the drainage. As the industry setup increase in the environment the water coming from industries are full of waste like polythene, bottles, and other materials and that water mix with the other water that are used by people and we know that water is not good for the health.so to replace our traditional way of cleaning gutter and to save the life of municipality cleaning workers we design this machine. In this machine we use following equipment's.

- 1) Shaft
- 2) Sprocket
- 3) chain
- 4) lifting bin
- 5) Metal rods for forming frame.

The biggest impact of cleaning the waste can cause respiratory system and it plays a challenging the chemical wastes can cause respiratory diseases and it plays a challenging issue for the municipality workers.

We have to build Automated drain cleaning machine with the main purpose of removing these solid materials from drains. This machine can be established at any point of drain easily. It has been designed in such a way that lets water flow through it but collects all the solid substances and gives a group in the dustbin. This machine is able to do cleaning and moving process together on the drains/gutters.

III. PROBLEM STATEMENT

The problem of water logging due to plastic, thermoscope and metal leads to pest growth and it favors diseases like malaria, typhoid etc. This is unsafe for human life and hence idea of this project emerged. he objective of proposed project Is to design and fabricate and automated machine for drainage cleaning in order to prevent humans from getting affected by various diseases from the infectious microbes present in sewage while

cleaning manually. This proposed system is to attenuate or overcome the matter faced while using man operated machine and to attenuate the increased dumping rate of waste.

The existing system is totally a mechanical based project. It is a stationary system, simply kept within the sewage area to gather the wastes passing over

it. The chain and sprocket are used for conveyor movement, which has fitted fork plates to collect the wastes from the sewage. The rotation of the chain alongside the plates will collect the floating wastes and postpone the wastes within the bin that's placed at the backside of the system.

CAD MODEL OF AUTOMATIC SEWAGAE CLEANING MACHINE

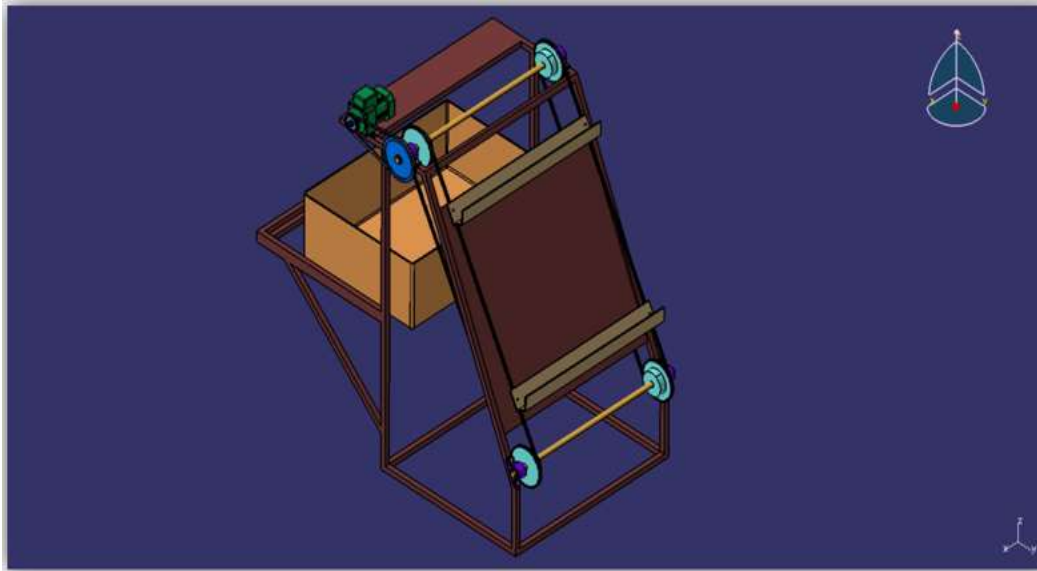

2D DRAWING OF AUTOMATIC SEWAGE CLEANING MACHINE

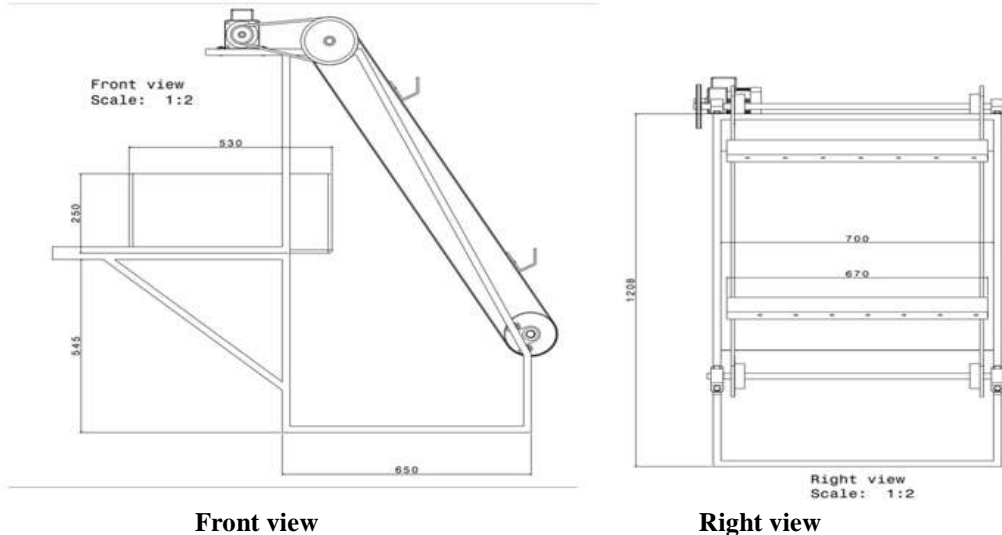

IV. MAIN COMPONENTS

- **Shaft**- A shaft is a rotating machine element, its cross section is circular, which is used to transmit power from one part to another part, or from a machine which produces power to a

machine which absorbs power. The various small parts such as pulleys, sprocket and gears are mounted on it.

- **Bearing block** - A bearing block may be a

machine element that contain a constrains relative motion to only the specified motion, and it reduces friction between moving parts. the planning of the bearing may, for instance, provide for free of charge of charge linear movement of the moving part or for free rotation around a hard and fast axis or it's going to prevent a motion by controlling the vectors of normal forces that bear on the moving parts.

- **Sprocket** - A sprocket or sprocket-wheel may be a profiled wheel with teeth, or cogs, that mesh with a sequence, track or other perforated or indented material. The name 'sprocket' applies generally to any wheel upon which radial projections engage a sequence passing over it. it's distinguished from a gear therein sprockets are never meshed together directly, and differs from a pulley therein sprockets have teeth and pulleys are smooth. Sprockets are utilized in bicycles, motorcycles, cars, tracked vehicles, and other machinery either to transmit rotation between two shafts where gears are unsuitable or to impart linear motion to a track, tape etc. Perhaps the foremost common sort of sprocket could also be found within the bicycle, during which the pedal shaft carries an outsized sprocket- wheel, which drives a sequence, which, in turn, drives a little sprocket on the axle of the rear wheel.
- **Chain** - Chain drive may be a way of transmitting mechanical power from one place to a different. it's often wont to convey power to the wheels of a vehicle, particularly bicycles and motorcycles. it's also utilized in a good sort of machines besides vehicles.
- **Lifter mount** - Lifting equipment, also referred to as lifting bin, may be a general term for any equipment which will be wont to lift loads. This includes sewages like polythene, plastic bottles, wastage which generally occurs within the water, thermocol, and other dusty and sewage partials which comes within the contact thereupon equipment. In our project we used two lifters for better performance, and it also help for balancing the model.
- **Collecting bin** - Collecting bin is that the rectangular hollow box which is situated behind the model. it's used for the aim of collecting the sewages which is comes within the contact of the lifter. When the lifter completes its cycle, it reaches to the bin and

removes all sewage within the collecting bin. The collecting bin made up from sheet.

- **Motor** - Electrical motor is electric machine. Main purpose of this motor is to convert electrical energy into mechanical energy. There are two type of motor AC motor and DC motor. According to all consideration we have use 90watt output. Required power output is 70 watts but considering all losses we have chosen 90-watt power output motor with 30 rpm speed and 12 volts voltage with 7amp current. Also Belt and Pulley are used to control speed of motor. If we want to control more speed of motor then we can use regulator.
- **Main frame** - The main frame is crucial part of machine. All forces and stresses are generated on this main frame. So, we have considered proper material for this frame. This main frame carries all parts like motor, bearing block, sprocket, shaft and chain so this frame should be more strengthener.

V. CONCLUSIONS

In the treatment system of drainage, waste water control by the machine and the collecting bin to achieve automatic control of waste water treatment. Drainage from domestic and industries is treated through this project to meet the national emission standards, with stable operation, low cost and good effect. The cleaner functions more effectively during the heavier rains which has more volume of running water with garbage and high velocity.

Risk of Labors catching infections or poisoning due to large amounts of waste and chemicals will be reduced. Automation includes the application of mechanical, electronic and computer-based systems to operate and control production. This system is used To Operate Automated Gutter Cleaning System.

This project is developed with the full utilization of men, machines, materials and money. Also, we have followed all the rules and regulations made our project economical and efficient with the available resources. This system is Designed, fabricated and also tested successfully. It works satisfactorily. We hope that this project be the most versatile and interchangeable one even in future. Thus, we can able to obtain following through Automated Gutter Cleaning system.

REFERENCES

- [1]. Theory of machines –S. S Rattan
Department of Mechanical Engineering
Regional Engineering Publication: Tata
McGraw-Hill Publishing company Limited.
- [2]. Design of machine elements by K
Raghavendra. first edition 2015
- [3]. Website- <https://www.astbearings.com> for
Bearing Block design catalogue
- [4]. Website- <https://www.transdev.co.uk> for
Simplex Sprockets design
- [5]. Website- <https://www.peerchain.com/> for
Design of Pintle chain
- [6]. Website- <https://www.swipfe.com/> for
Design of Motor
- [7]. [https://en.wikipedia.org/wiki/Drainage system](https://en.wikipedia.org/wiki/Drainage_system)
- [8]. R. Sathiyakala et.al., “Smart Sewage
Cleaning System” International Journal of
Innovative Research in Computer and
Communication Engineering, Vol No- 4,
February 2016.
- [9]. Ganesh U L, Vinod Rampur, Semi-
automatic drain for sewage water treatment
of floating materials, July 2016
- [10]. Dr.K. Kumaresan, “Automated
Sewage(gutter) Cleaning Machine”.
Chaudhry FN, Malik MF, Factorised
affecting water pollution, March 2017
- [11]. Nitin Sall, water from homes, apartments,
business industries, commercial activities
waste water
- [12]. James C. Conwell, G. E. Johnson, The
planning and construction of a replacement
test machine configuration.
- [13]. S D Rahul Bharadwaj, Automatic cleaning
of waste water to prevent global warming
and melting of glaciers.
- [14]. Ndubuisi.C. Daniels, the drainage system
cleaner machine used to remove garbage and
sewage automatically.
- [15]. Balachandraetal, “Automated drainage pump
monitoring and system” using PLC and
SCADA. PLC and SCADA were designed.