

## Dis-Infectant Service Robot

Shubham Dash, Sachin Pal, Reependra Kumar, Sanjay Ojha

*Department of Electronics and Communication Engineering  
IMS Engineering College, Ghaziabad*

Submitted: 30-07-2021

Revised: 06-08-2021

Accepted: 08-08-2021

### ABSTRACT :

Use of these disinfection robots reduce the risk of infection, cost of traditional cleaning and disinfection, and most importantly acquires confidence and security of individuals. In this paper, we design a model for robot-disinfectant. This robot is inspired on/from a technique, which consists of disinfecting places autonomously in order to save human life from infections. The main advantages of the designed robot are the novelty, multi-functionality, and the availability at an affordable cost.

Hygiene and sanitation requirements have always been the most significant factor to stay healthy in human life. Proper cleaning and sanitation measures are one of the important ways to fight against various viruses. In recent years, the use of modern technology in sanitation has helped to fight against infectious diseases. One such modern technology is disinfection robot. Disinfection robots are increasingly used in all around the world.

The main components used in the proposed implementation are Arduino, Wifi-Module, Motor Driver (L293D), Relay Circuit. The main features of the proposed systems include- Saves time, 360° disinfection coverage, Automated controlled working ability, Helps to keep hygiene, Reduce effort of workers.

**Keywords-** Dis-infection, Relay, Arduino, Motor Driver IC, Node MCU ESP8266

### I. INTRODUCTION: DIS-INFECTANT SERVICE ROBOT

This project is made for the purpose of deep cleaning and disinfect small (Corner) areas present in metro, stations, Train Compartment, Airport, Schools, Malls etc. that people can't handle

that is most important thing specially during this pandemic situation.

This **Dis-infectant Service Robot** is very useful to be carry out for deep cleaning and decontamination in train compartments, railway stations, metro, Malls or other big areas where probably most of the crowd is to be present and can reduce the risk of getting infected.

This is expected to boost hygiene and health protection for passengers and staff amid the coronavirus (Covid-19) pandemic.

The robot ensures that disinfectants get into even small gaps that are otherwise difficult to reach during the regular cleaning process. This process can eliminate viruses and bacteria.

In the event disinfection is to be carried out, the operator can preset the service robot to operate automatically by pre-setting the floorplan of the required area. The operator can also remotely control the robot manually with a mobile device within a distance of 20-30 meter.

However, under a special situation such as a passenger vomiting on a train, robot to carry out deep cleaning and hygiene that place with the help of floor cleaner.

The robot sprays a sanitizer mist into nooks and crannies, to disinfect surfaces that cleaning staff cannot reach.

This Robot designed to disinfect trains, stations, to combat the spread of the COVID-19.

The robot is called the "**Dis-infectant Service Robot**" Shaped like a small refrigerator, the machine automatically sprays a liquid sanitizer solution to disinfect surfaces on the subway.

The Robot's spraying mechanism is designed to reach areas that manual cleaning staff cannot successfully disinfect by hand.

## II. BLOCK DIAGRAM:

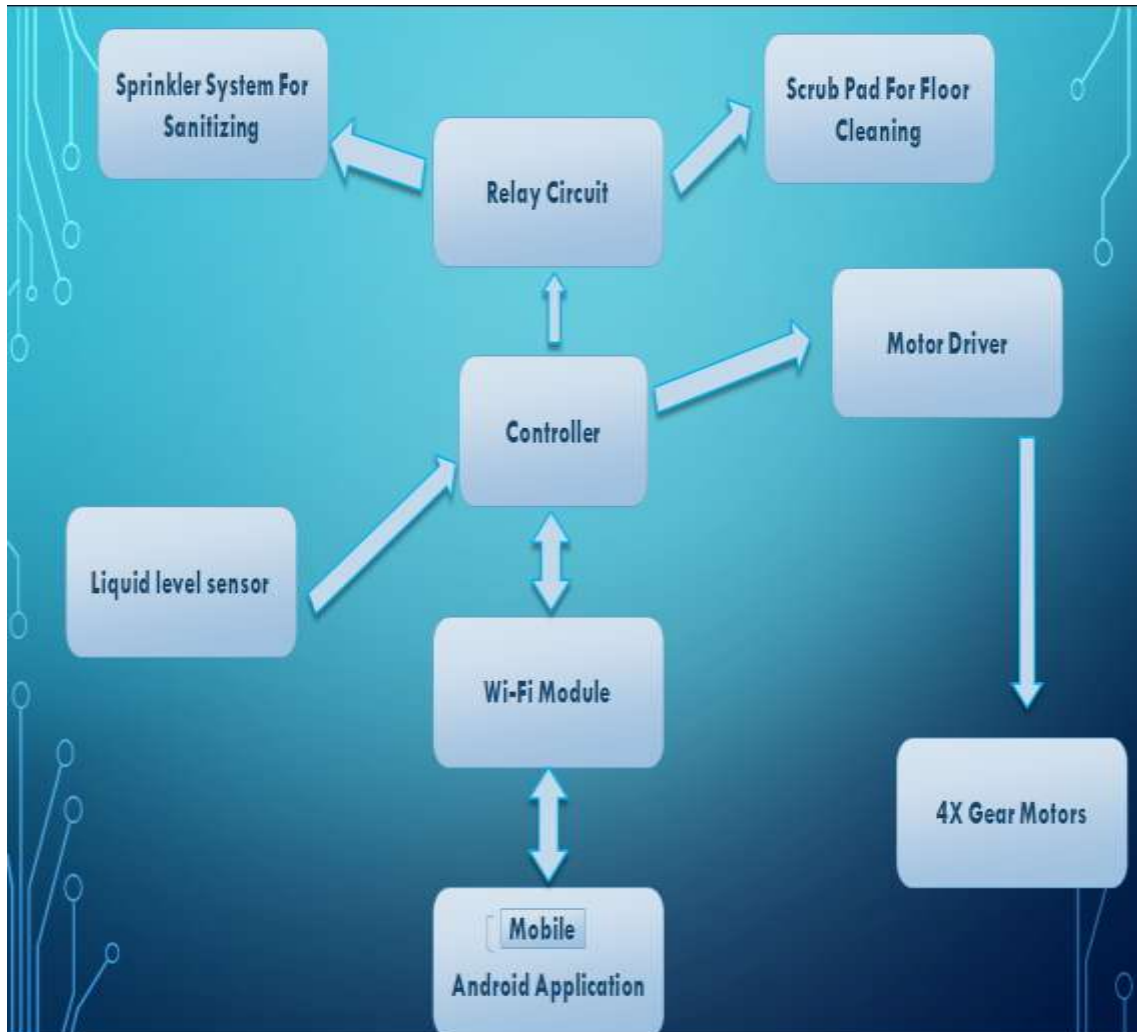

Fig.1 The Block Diagram of Dis-infectant Service Robot.

## III. PROJECT REQUIREMENTS IN DIS-INFECTANT SERVICE ROBOT:

### Hardware Required: -

1. Arduino Mega
2. Wi-Fi Module or Bluetooth Module
3. Motor Driver (L293D Or L298N)
4. Four Gear Motor
5. Pressure Motor for Sprinkler System
6. Liquid Level Sensor
7. Relay
8. Ultra-Sonic Sensor (HC-SR04)
9. Scrub Pad (Floor Cleaner)
10. Battery

### Software Required: -

1. C or C++
2. Arduino IDE
3. MIT Application Inventor or Android Studio

### 3.1 ARDUINO:

Arduino is an open-source hardware and software company, project and user community that designs and manufactures single-board microcontrollers and microcontroller kits for building digital devices. The Arduino Uno is an open-source microcontroller board based on the Microchip ATmega328P microcontroller and developed by Arduino.cc.[4] The board is equipped with sets of digital and analog input/output pins that may be interfaced to various expansion boards and other circuits. The Arduino MEGA 2560 shown in Fig.3 is designed for projects that require more I/O lines, more sketch memory and more RAM. With 54 digital I/O pins, 16 analog inputs and a larger space for your sketch it is the

recommended board for 3D printers and robotics projects.

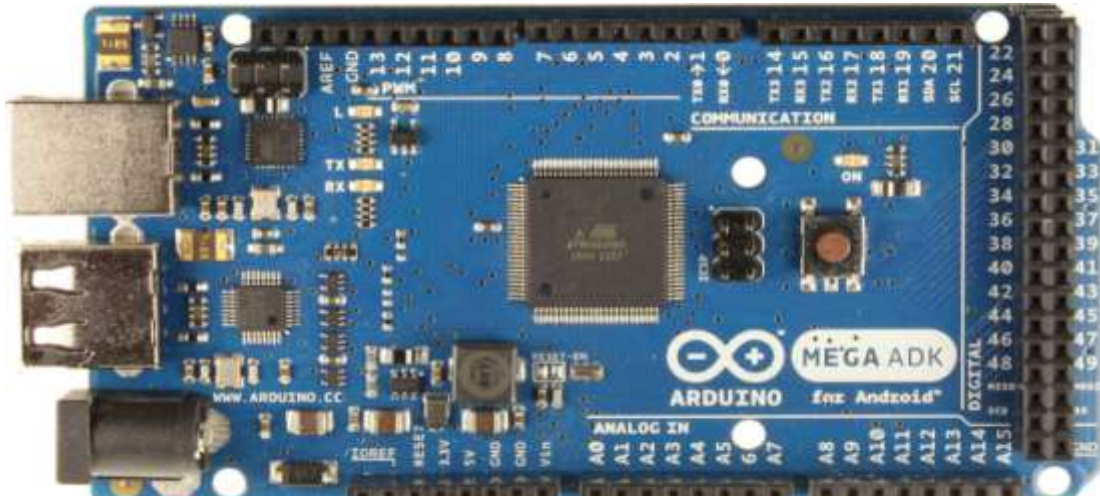

Fig-2 The picture of Arduino mega2560

### 1.2 NODE MCU ESP8266(Wifi-module) :-

NodeMCU is an open-source firmware and development kit that helps you to prototype or build IoT products. It includes firmware that runs on the ESP8266 Wi-Fi SoC from Espressif Systems, and hardware which is based on the ESP-12 module. The firmware uses the Lua scripting language. It is based on the eLua project and built on the Espressif Non-OS SDK for ESP8266.

The **NodeMCU ESP8266 development board** comes with the ESP-12E module containing

ESP8266 chip having Tensilica Xtensa 32-bit LX106 RISC microprocessor. This microprocessor supports RTOS and operates at 80MHz to 160 MHz adjustable clock frequency. NodeMCU has 128 KB RAM and 4MB of Flash memory to store data and programs. Its high processing power with in-built Wi-Fi / Bluetooth and Deep Sleep Operating features make it ideal for IoT projects. NodeMCU can be powered using Micro USB jack and VIN pin (External Supply Pin). It supports UART, SPI, and I2C interface.



Fig-3 NodeMCU ESP8266

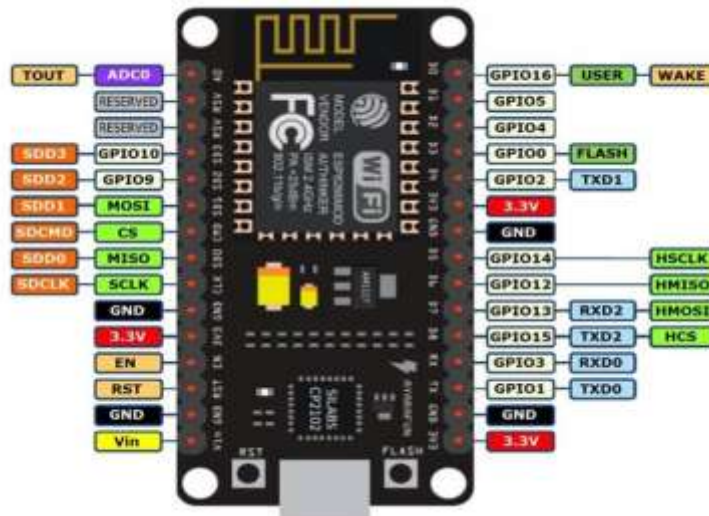

Fig-4 NODE MCU 8266 PIN OUT

**1.3 L293D motor-driver IC:**

L293D is a typical Motor driver or Motor Driver IC which allows DC motor to drive on either direction. L293D is a 16-pin IC which can control a set of two DC motors simultaneously in

any direction. It means that you can control two DC motor with a single L293D IC. Dual H-bridge Motor Driver integrated circuit (IC). The L293d can drive small and quiet big motors as well.



Fig-5 L293D motor-driver IC

**3.4 Relay Circuit:**



Fig-6 RELAY CIRCUIT.

A relay is an electromagnetic switch that opens and closes circuits electromechanically or electronically. A relatively small electric current that can turn on or off a much larger electric current operates a relay. Relays work like some electrical products since they receive an electrical signal and send the signal to other equipment by turning the switch on and off. Even if the relay contact is normally closed or normally open, they are not

energized. Its state will change only if you apply an electrical current to the contact.

Relays are useful in many applications. Electromagnetic relays protect various AC and DC equipment. It is also used as auxiliary relays in the contact systems of protective relay schemes, for differential protection and the over- or under-current protection of various AC and DC equipment. The current carrier pilot relaying scheme protects transmission lines.

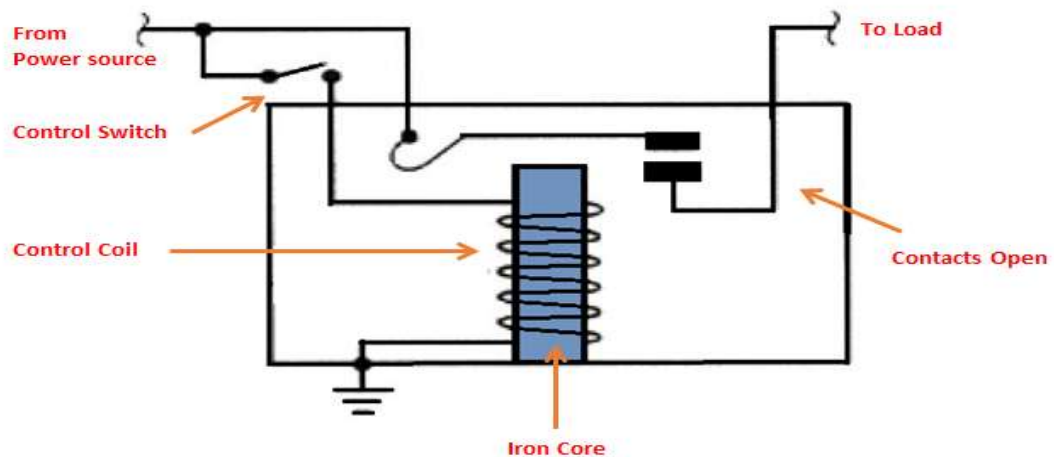

Fig-7 Relay Design.

Relays can operate in two ways. The first is in low voltage application, and the other is in high voltage application. It is used to reduce the noise of the whole circuit in low voltage applications. On the other hand, relays reduce arcing in high voltage applications.

#### IV. KEY FEATURES OF DISINFECTANT SERVICE ROBOT:

1. **360° disinfection coverage.**
  - The disinfection coverage of this robot is one of the biggest advantage as in this sprinkler system is used which can help to spray the sanitizer solution throughout the areas in 360 degrees can be operated by mobile phone as per required.
2. **Automated controlled working ability.**
  - Can work effectively using remote device that is application is used in the mobile phone to operate the robot.
3. **Helps to keep hygiene.**
  - As the robot is containing floor cleaner as well so can be use for the application of cleaning and to keep hygiene the infected places specially in the pandemic situation.

#### 4. Reduce effort of workers.

- We need more workers and staffs members for sanitizing and keeping hygiene of bigger and crowded areas for instance railways, railway station, metro, malls etc. So in that place we can implement this Dis-infectant service robot to reduce effort of workers.

#### 5. Saves time.

- As many workers are need to sanitise the areas as usual that need more time also in place of that this robot will help to reduce time also.

#### V. CONCLUSION :

- The current COVID-19 pandemic boosts innovation on many public, societal and medical levels and disinfection practices are not an exception. Disinfection robots are a promising tool for surface decontamination in the infected areas already today, but with even greater potential tomorrow.
- Further adjustments of areas and devices are needed to overcome the issue of deep cleaning or disinfecting and need of the movement of robots in the areas like hospitals, railway stations, crowded environment to disinfect.
- The corona virus is presenting an increasing and urgent need for quarantine and disinfection

operations and cleaning surfaces. Potentially contaminated surfaces must be frequently cleaned, to prevent further spread of the virus.

- Prevention from virus is needs immediate cure and steps should be taken so using the disinfection robots where its need is much more important and to be cleaning of places where infection effects are there most probably.

#### **REFERENCE :**

1. <https://www.railwaygazette.com/technology-data-and-business/metro-operator-deploys-cleaning-robot-to-fight-the-coronavirus/55995.article>
2. <https://www.internationales-verkehrswesen.de/covid-19-hong-kongs-mtr-deploys-vhp-robot-for-disinfection/>